

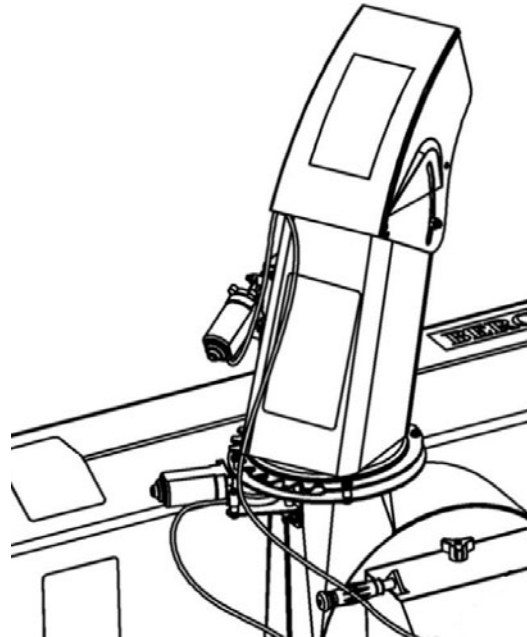

**OWNER'S MANUAL**  
*Model Number*

700518



***BERCO***  
***Electric chute & deflector kit***  
***for Northeast Snowblowers***

- \* ASSEMBLY
- \* OPERATION
- \* REPAIR PARTS
- \* MAINTENANCE

**CAUTION:**  
**READ & FOLLOW ALL SAFETY RULES & INSTRUCTIONS BEFORE  
OPERATING YOUR EQUIPMENT**



# LIMITED WARRANTY

## Conditions and Products Covered:

BERCOMAC guarantees any part of the product or accessory manufactured by BERCOMAC and found in the reasonable judgment of BERCOMAC to be defective in material and or workmanship will be repaired or replaced by an authorized dealer without charge up to our maximum labor rates and pre-established times. For replacement parts only standard ground freight services are covered. This warranty extends to the original retail purchaser only and is not transferable to any subsequent purchasers.

## Warranty Period

(from date of the original retail purchase)

- Residential use: 1 year
- Semi-commercial, professional or rental use: 90 days

**Exceptions Noted Below;** the following items are guaranteed by the original manufacturer and have their own warranty, conditions and limited time:

- Tire Chains: 90 days
- Engines (installed in factory on BERCO equipment): 2 years
- Engines (sold separately): Validate with the dealer. Please refer to the engine manufacturer's warranty statement included with the unit. BERCOMAC is not authorized to handle warranty adjustments on engines.

## Items and Conditions NOT Covered:

This warranty does not cover the following:

- Pick-up or delivery charges or in-home services fees.
- Any damage or deterioration of the unit, parts and or finish of these due to normal use, wear and tear, or exposure.
- Cost of regular use or maintenance service or parts, such as gas, oil, lubricants, tune-up parts, and adjustments.
- Any part or accessory which has been altered, modified, misused, neglected, accidentally damaged or not properly installed, maintained, stored or repaired not in accordance with the instructions in the owner's manual.
- Repair due to normal wear and or any wear items such as shear pins, bolts, belts, etc.
- Expedited freight fee services for replacement parts.
- Shear bolts and shear pins are to be considered as a preventive measure not as an assured protection, any damages resulting from the lack of shear bolts breakage are not covered.

NOTE: All warranty work must be performed by an authorized dealer using original (manufacturer) replacement parts.

**NOTE:** Bercomac reserves the right to change or improve the design of any part or accessory without assuming any obligation to modify any product previously manufactured.

## Instructions for Obtaining Warranty Services:

Contact dealer where equipment was purchased or any other BERCOMAC service dealer to arrange service at their dealership. To locate a dealer convenient to you, access our website at [www.bercomac.com](http://www.bercomac.com). Don't forget to bring the product and your proof of purchase (sales receipt) to the BERCOMAC dealer.

## Owner's Responsibilities:

BERCOMAC's defective equipment or part must be returned to an authorized dealer within the warranty period for repairs. In the event that defective merchandise must be returned to manufacturer for repairs, freight fees are prepaid and a written authorization from BERCOMAC must be obtained by dealer prior to the shipment. This warranty extends only to equipment operated under normal conditions. To validate a warranty claim, it is the user's responsibility to maintain and service the unit as specified in the owner's manual or to have the unit serviced at their dealer at their expense.

## General Conditions:

The sole liability of BERCOMAC with respect to this warranty shall be strictly and exclusively repair and replacement as mentioned herein. BERCOMAC shall not have any liability for any other costs, loss or damage, including but not limited to, any incidental or consequential loss or damage.

In particular, without being limited to, BERCOMAC shall have no liability or responsibility for:

- Travel time, overtime, after hours time or other extraordinary repair charges or relating to repairs and or replacements outside of normal business hours.
- Rental of like or similar replacement equipment during the period of any, repair or replacement work.
- Any communicating or travel charges.
- Loss or damage to person or property other than that covered by the terms of this warranty.
- Any claims for lost revenue, lost profit or any similar costs as a result of damage or repair.
- Attorney's fees.

BERCOMAC's responsibility in respect to claims is limited to making the required repairs or replacement without charge up to our maximum labor rates and pre-established times and no claim of breach of warranty shall be cause for cancellation or rescission of the contract of sale of any product or accessory.

This warranty gives you specific legal rights. You may also have other rights, which vary from state to state.

# TABLE OF CONTENTS

INTRODUCTION .....	2
SAFETY PRECAUTIONS .....	3
TOOLS REQUIRED .....	3
ASSEMBLY	
Step 1: Installation of the Electric Chute Rotation Kit on the Northeast Snowblower .....	4
Step 2: Electric Deflector Adjustment Kit .....	5
Step 3: Installation of the Electric Control Box .....	6
TROUBLESHOOTING .....	7
PARTS BREAKDOWN AND LISTS	
Electric Chute & Deflector Kit .....	8

# INTRODUCTION

**TO THE PURCHASER**

This new accessory was carefully designed to give years of dependable service. This manual has been provided to assist in the safe operation and servicing of your attachment.

**NOTE:** All photographs and illustrations in the manual may not necessarily depict the actual models or attachment, but are intended for reference only and are based on the latest product information available at the time of publication.

Familiarize yourself fully with the safety recommendations and operating procedures before putting the machine to use. Carefully read, understand and follow these recommendations and insist that they be followed by those who will use this attachment.



**THIS SAFETY ALERT SYMBOL IDENTIFIES AN IMPORTANT SAFETY MESSAGE IN THIS MANUAL THAT HELPS YOU AND OTHERS AVOID PERSONAL INJURY OR EVEN DEATH. DANGER, WARNING, AND CAUTION ARE SIGNAL WORDS USED TO IDENTIFY THE LEVEL OF HAZARD. HOWEVER, REGARDLESS OF THE HAZARD, BE EXTREMELY CAREFUL.**

**DANGER:** Signals an extreme hazard that will cause serious injury or death if recommended precautions are not followed.

**WARNING:** Signals a hazard that may cause serious injury or death if the recommended precautions are not followed.

**CAUTION:** Signals a hazard that may cause minor or moderate injury if the recommended precautions are not followed.

Record your attachment serial number and purchase date in the section reserved below (there is no serial number on the subframe). Your dealer requires this information to give you prompt, efficient service when ordering replacement parts. Use only genuine parts when replacements are required.

If warranty repairs are required please present this registration booklet and original sales invoice to your selling dealer for warranty service.

**This manual should be kept for future reference.  
Please check if you have received all the parts for your kit with the list of the bag and the list of the box.**

<b>SERIAL NUMBER :</b> (IF APPLICABLE)	
<b>MODEL NUMBER:</b>	
<b>PURCHASE DATE :</b>	

# SAFETY PRECAUTIONS

Careful operation is your best insurance against an accident. Read this section carefully before operating the tractor and attachment. All operators, no matter how experienced they may be, should read this and other manuals related to the tractor and attachments before operating. It is the owner's legal obligation to instruct all operators in safe operation.

## TRAINING



This symbol, "Safety Alert Symbol", is used throughout this manual and on the attachment safety labels to warn of the possibility of personal injury. Please take special care in reading and understanding the safety precautions before operating the attachment or the tractor.

1. Read the snowblower owner's manual carefully. Be thoroughly familiar with the controls and proper use of the attachment.
2. Keep hands and feet away from the chute and all other moving parts.

## WHENEVER YOU SEE THIS SYMBOL



**IT MEANS:**

**WARNING!**

**BECOME ALERT !**

**YOUR SAFETY IS INVOLVED!**

# ASSEMBLY

## TOOLS REQUIRED:

Ratchet  
Wrench (for the nuts on the posts of the battery on the vehicle)  
Wrench 7/16"  
Socket 7/16", 1/2"  
Drill  
Bit 9/32"

# ASSEMBLY

## **STEP 1** **INSTALLATION OF THE ELECTRIC CHUTE** **ROTATION KIT ON THE NORTHEAST** **SNOWBLOWER**

Dismount the supports (item 1) and rotation worm (item 2), the chute (item 3) and rotation ring (item 4) if already installed.

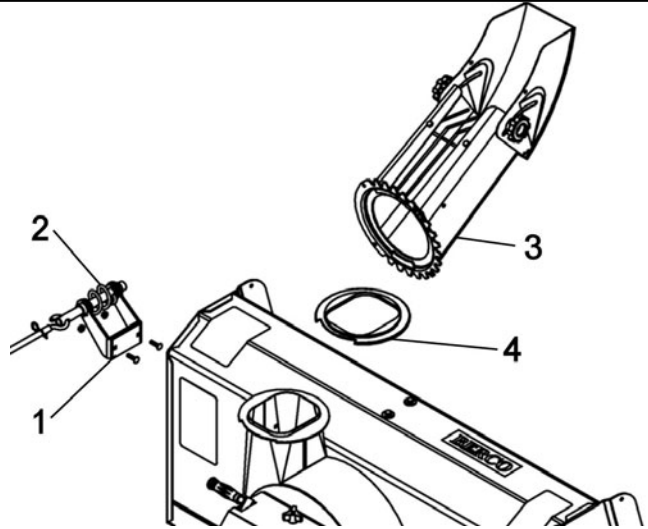

Dismount the chute

Install the rotation ring (item 1) under the chute (item 2) using the four spacers (item 3) and four hex bolts 1/4 x 1" (item 4).  
Secure with four nylon insert lock nuts.  
(Make sure the rotation ring is placed as shown).

Reinstall the chute on the snowblower.

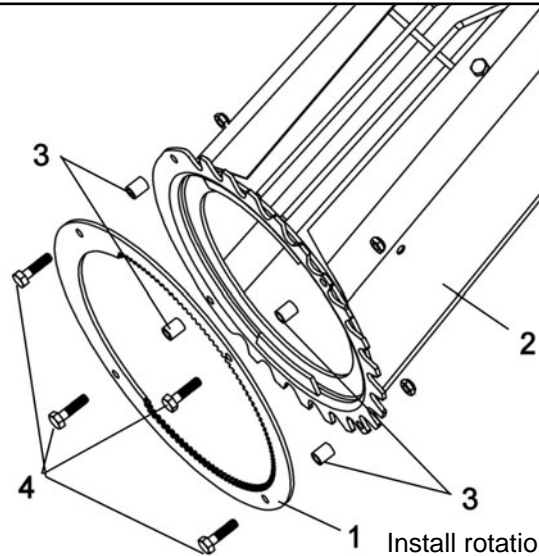

Install rotation ring

Install the reinforcement plate (item 1) on the motor assembly (item 2).

Secure the motor assembly on the snowblower as shown with the two 1/4 x 1" hex bolts (item 3) and nuts previously removed.

Tighten all the bolts firmly.

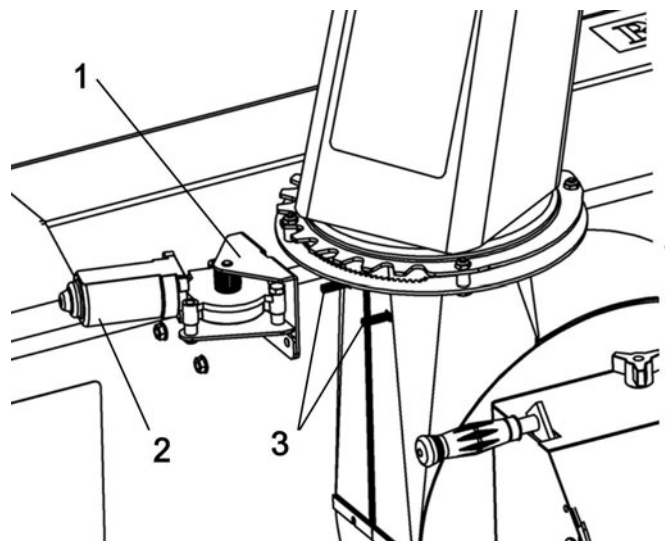

Install the motor

# ASSEMBLY

## STEP 2 INSTALLATION OF THE ELECTRIC DEFLECTOR ADJUSTMENT KIT :

Remove the two knobs (item 1) from the deflector and replace them by two nylon washers 11/32" and two 5/16" nylon insert lock nuts.

DO NOT TIGHTEN COMPLETELY so that the deflector moves freely.

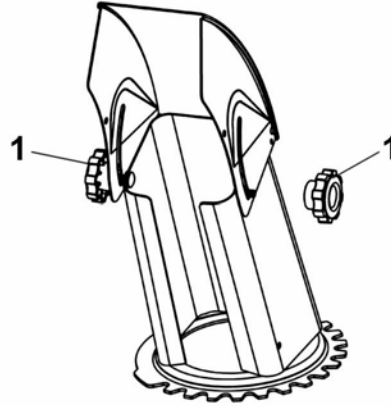

Remove knobs and replace with nylon washers and nylon insert lock nuts.

Install the assembled electric motor on the chute with a 1/4 x 1/2" screw and a nylon insert lock nut (item 1) (nut on the outside).

Place the base of the motor bracket parallel with the base of the chute.

Tighten the screw firmly.

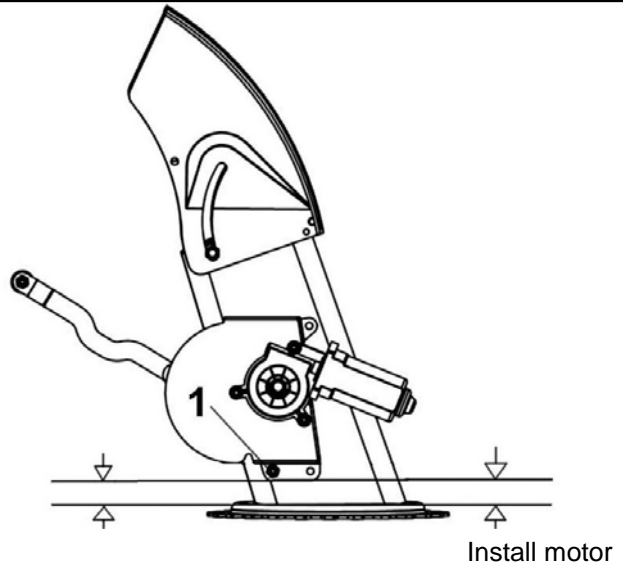

Drill two 9/32" holes (item 2) in the chute by using the bracket as a template.

**BE CAREFUL, BEFORE DRILLING THE HOLES, MAKE SURE THAT THE BASE OF THE MOTOR BRACKET IS PARALLEL WITH THE BASE OF THE CHUTE.**

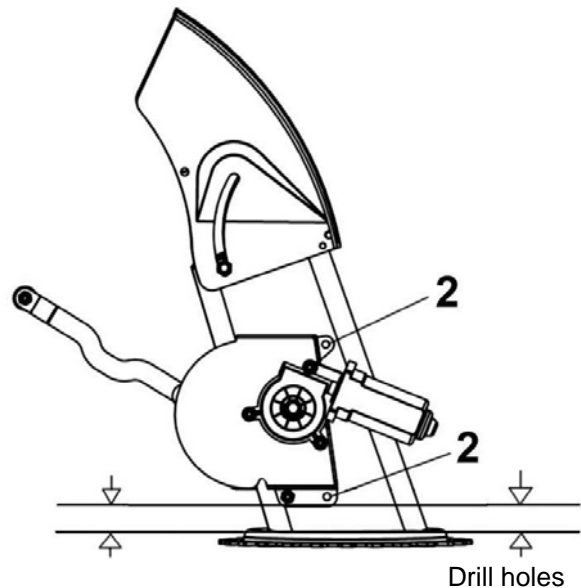

# ASSEMBLY

Secure the bracket with two 1/4 x 1/2" screws and nylon insert lock nuts (item 1) (nuts on the outside).

Tighten the screws firmly.

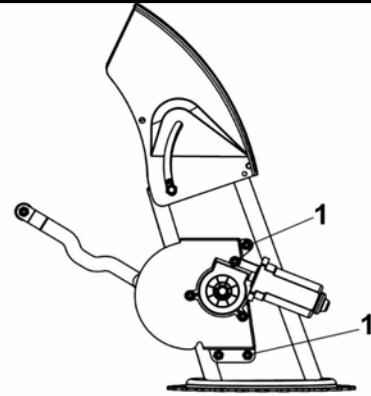

Secure with screws

Install the arm (item 1) on the deflector (item 2) with a 1/4 x 3/4" bolt (item 3) (the head inside the chute), a 5/16" flat washer between the arm and the deflector and a nylon insert lock nut on the outside.

DO NOT TIGHTEN COMPLETELY so that the deflector moves freely.

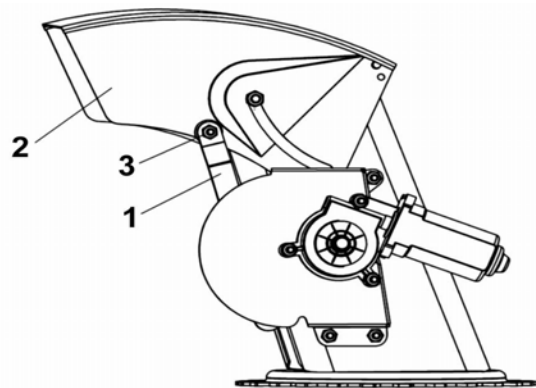

Install arm

## **STEP 3** **INSTALLATION OF THE ELECTRIC CONTROL:**

**NOTE:** Before choosing the ideal place to install the control support (item 1) and control box, connect the control box wires to the motors and to the battery (see instructions on next page).

Use the joystick to determine which direction activates which motor.

We suggest putting the control box on the right fender of the tractor close to the driver's seat or close to the steering wheel according to your preference.

Secure the control support with two 1/4 x 3/4" bolts and flange nuts.

Install the control box on the support.

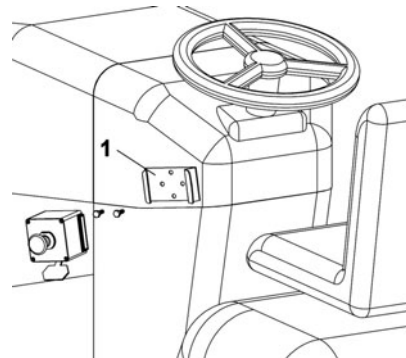
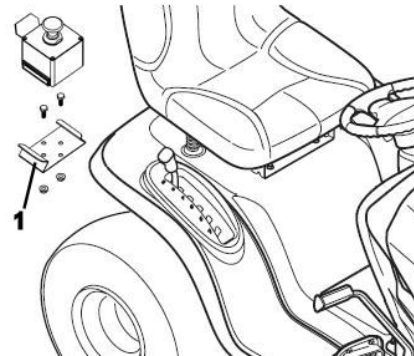

Determine direction of joystick and position of control box before installing the support.



# ASSEMBLY

Thread the wires on the frame to the front where they will not be seen and where they won't touch any hot or moving parts.

Attach to the vehicle's frame using the tie wraps.

**NOTE:** It is recommended to place the wire connectors as close as possible to the subframe. Secure the wires in an adequate place in order to separate the accessory from the vehicle when storing.

Connect the wires to the electric motors. The longest wires are connected to the deflector motor.

Connect the red wire to the positive battery post and the black wire to the negative battery post.

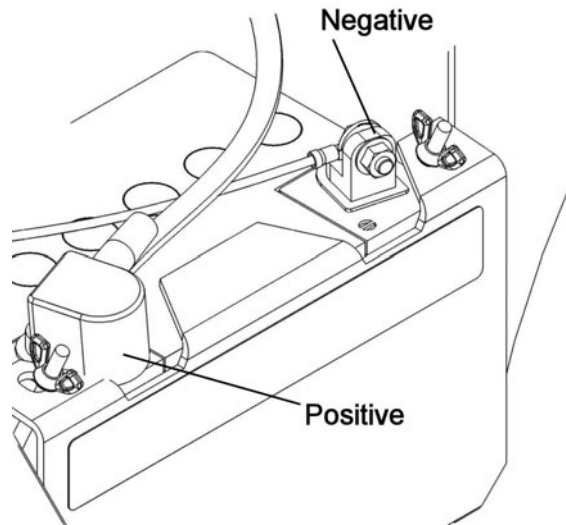

Connect the wires to the motors and battery.

Turn the chute to its maximum towards the right.

Secure the wire for the deflector motor (item 1) with a tie wrap around the motor.

Tie the wire for the deflector with another tie wrap in the hole (item 3) at the base of the deflector as shown.

Secure the wires for the rotation motor (item 2) with a tie wrap.

Be sure to leave enough wire length to be able to turn the chute.

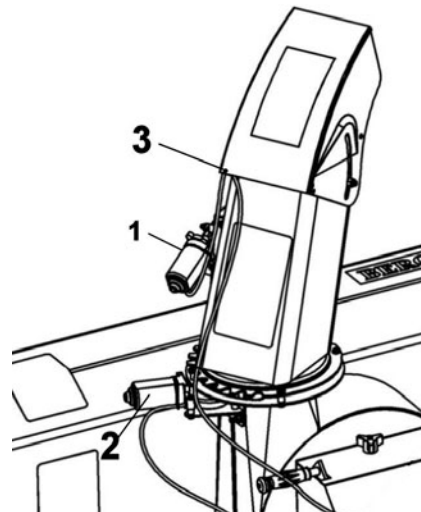

Secure wires on the motors

## TROUBLESHOOTING

(For identification, see the parts breakdown)

PROBLEM	POSSIBLE CAUSES	CORRECTIVE ACTION
Electric motor does not work	Overheating of the motor	These motors are equipped with an internal protector. Wait 10 minutes before using.

**PARTS BREAKDOWN  
ELECTRIC CHUTE & DEFLECTOR KIT**

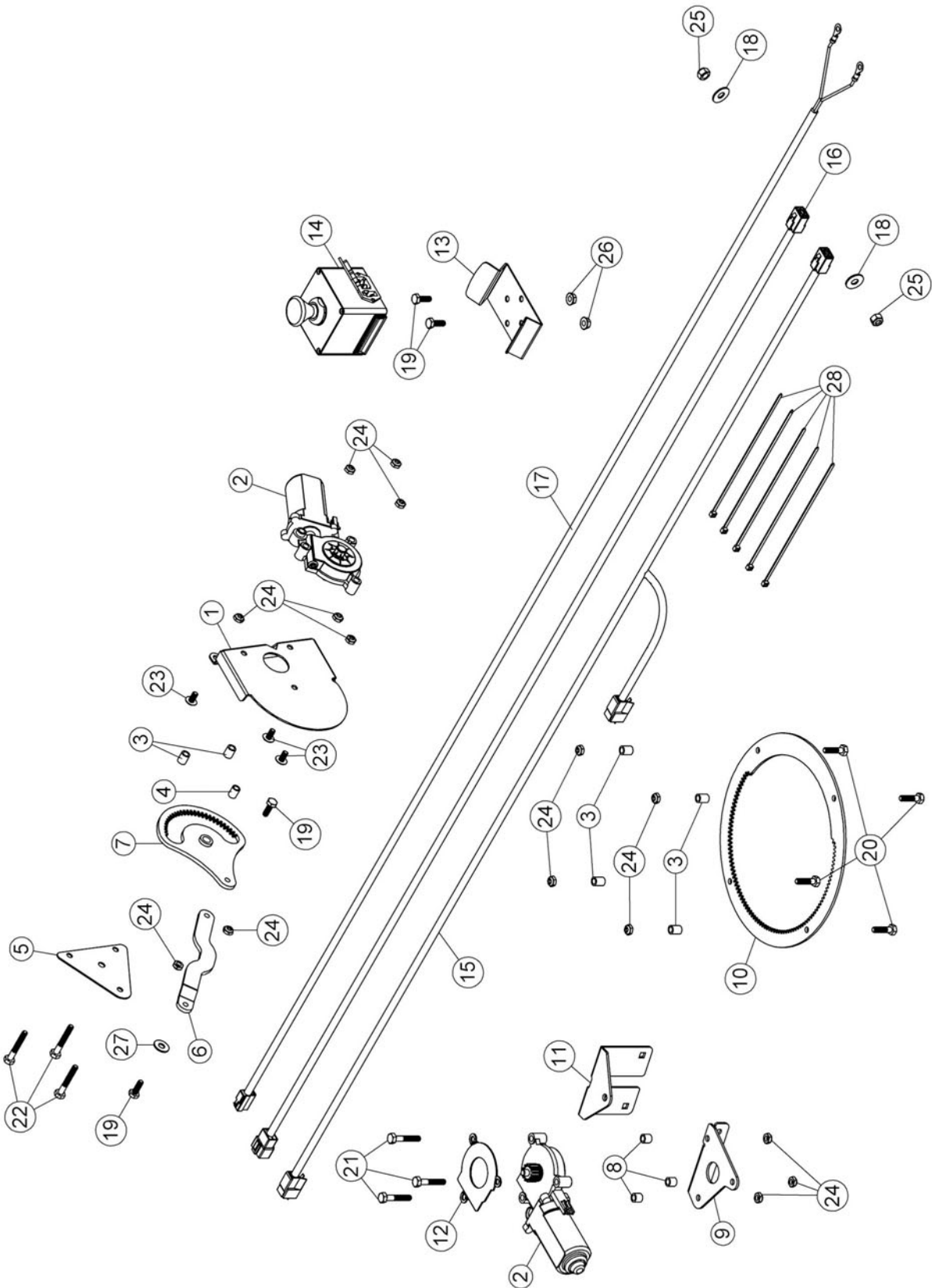

## PARTS LIST ELECTRIC CHUTE & DEFLECTOR KIT

Ref.	English description	Description française	Qty.	Part #
1	Bracket	Support	1	103375
2	Electric motor	Moteur électrique	2	103378
3	Spacer	Espaceur	6	103361
4	Oil lite bushing	Coussinet imprégné d'huile	1	103362
5	Plate	Plaque	1	103363
6	Arm	Bras	1	103364
7	Lever	Levier	1	103365
8	Spacer	Espaceur	3	103368
9	Bracket	Support	1	103971
10	Rotation ring	Anneau de rotation	1	103974
11	Reinforcement plate	Plaque de renforcement	1	103972
12	Protective plate	Plaque protectrice	1	105404
13	Box support	Support de la boîte	1	105395
14	Control box	Boîtier de contrôle	1	105325
15	Wire control box	Fil de la boîte de contrôle	1	105326
16	Wire control box extension	Extension du fil de la boîte de contrôle	1	105405
17	Wire assembly	Fil assemblé	1	105390
18	Nylon flat washer 11/32"	Rondelle plate de nylon 11/32"	2	102009
19	Hex. bolt 1/4" n.c. x 3/4"	Boulon hex. 1/4" n.c. x 3/4"	4	O/L
20	Hex. bolt 1/4" n.c. x 1"	Boulon hex. 1/4" n.c. x 1"	4	O/L
21	Hex. bolt 1/4" n.c. x 1 1/2"	Boulon hex. 1/4" n.c. x 1 1/2"	3	O/L
22	Hex. bolt 1/4" n.c. x 1 3/4"	Boulon hex. 1/4" n.c. x 1 3/4"	3	O/L
23	Machine screw T.H. 1/4" n.c. x 1/2"	Vis mécanique T.H. 1/4" n.c. x 1/2"	3	O/L
24	Nylon insert lock nut 1/4" n.c. (thin)	Écrou à garniture de nylon 1/4" n.c.(mince)	15	O/L
25	Nylon insert lock nut 5/16" n.c.	Écrou à garniture de nylon 5/16" n.c.	2	O/L
26	Flange nut 1/4" n.c.	Écrou à bride 1/4" n.c.	2	O/L
27	Flat washer 5/16" hole	Rondelle plate 5/16" trou	1	O/L
28	Tie wrap 8"	Attache de nylon 8"	5	O/L

O/L = Obtain locally / obtenir localement



***WHEN PERFORMANCE  
& DEPENDABILITY  
ARE NON NEGOTIABLE!***

Bercomac Limitée  
92, Fortin North, Adstock, Quebec, Canada, G0N 1S0

[WWW.BERCOMAC.COM](http://WWW.BERCOMAC.COM)

PRINTED IN CANADA