



OWNER'S MANUAL

(Original version)

Model Number

700580-1

700582-1

700360-10



BERCO ***Versatile Plus 48" & 54" Snowblower*** ***and Prestige 54' Snowblower*** for ***ALL TERRAIN VEHICLES & UTILITY VEHICLES***

- * ASSEMBLY
- * OPERATION

- * REPAIR PARTS
- * MAINTENANCE

CAUTION:

**READ & FOLLOW ALL SAFETY RULES & INSTRUCTIONS BEFORE
OPERATING YOUR EQUIPMENT**



LIMITED WARRANTY

Conditions and Products Covered:

BERCOMAC guarantees any part of the product or accessory manufactured by BERCOMAC and found in the reasonable judgment of BERCOMAC to be defective in material and or workmanship will be repaired or replaced by an authorized dealer without charge up to our maximum labor rates and pre-established times. For replacement parts only standard ground freight services are covered. This warranty extends to the original retail purchaser only and is not transferable to any subsequent purchasers. This warranty applies to the products bought and used in North America.

Warranty Period

(from date of the original retail purchase)

- Residential use: 1 year
- Semi-commercial, professional or rental use: 90 days

Exceptions Noted Below; the following items are guaranteed by the original manufacturer and have their own warranty, conditions and limited time:

- Tire Chains: 90 days
- Engines: Will vary as per the manufacturer
Please refer to the engine manufacturer's warranty statement included with the unit. BERCOMAC is not authorized to handle warranty adjustments on engines.

Items and Conditions NOT Covered:

This warranty does not cover the following:

- Pick-up or delivery charges or in-home services fees.
- Any damage or deterioration of the unit, parts and or finish of these due to normal use, wear and tear, or exposure.
- Cost of regular use or maintenance service or parts, such as gas, oil, lubricants, tune-up parts, and adjustments.
- Any part or accessory which has been altered, modified, misused, neglected, accidentally damaged or not properly installed, maintained, stored or repaired not in accordance with the instructions in the owner's manual.
- Repair due to normal wear and or any wear items such as shear pins, bolts, belts, etc.
- Expedited freight fee services for replacement parts.
- Shear bolts and shear pins are to be considered as a preventive measure not as an assured protection, any damages resulting from the lack of shear bolts breakage are not covered.
- Damages due to product being installed on a vehicle other than stipulated in owner's manual.

NOTE: All warranty work must be performed by an authorized dealer using original (manufacturer) replacement parts.

NOTE: Bercomac reserves the right to change or improve the design of any part or accessory without assuming any obligation to modify any product previously manufactured.

Instructions for Obtaining Warranty Services:

Contact dealer where equipment was purchased or any other BERCO service dealer to arrange service at their dealership. Requests for warranty claims must be carried out through the same distribution network used to purchase the product. Don't forget to bring your proof of purchase (sales receipt) to the BERCOMAC dealer.

Owner's Responsibilities:

BERCOMAC's defective equipment or part must be returned to an authorized dealer within the warranty period for repairs. In the event that defective merchandise must be returned to manufacturer for repairs, freight fees are prepaid and a written authorization from BERCOMAC must be obtained by dealer prior to the shipment. This warranty extends only to equipment operated under normal conditions. To validate a warranty claim, it is the user's responsibility to maintain and service the unit as specified in the owner's manual or to have the unit serviced at their dealer at their expense.

General Conditions:

The sole liability of BERCOMAC with respect to this warranty shall be strictly and exclusively repair and replacement as mentioned herein. BERCOMAC shall not have any liability for any other costs, loss or damage, including but not limited to, any incidental or consequential loss or damage. Taking advantage of the warranty does not in any way extend the length or renewal of the warranty.

In particular, without being limited to, BERCOMAC shall have no liability or responsibility for:

- Travel time, overtime, after hours time or other extraordinary repair charges or relating to repairs and or replacements outside of normal business hours.
- Rental of like or similar replacement equipment during the period of any, repair or replacement work.
- Any communicating or travel charges.
- Loss or damage to person or property other than that covered by the terms of this warranty.
- Any claims for lost revenue, lost profit or any similar costs as a result of damage or repair.
- Attorney's fees.

BERCOMAC's responsibility in respect to claims is limited to making the required repairs or replacement without charge up to our maximum labor rates and pre-established times and no claim of breach of warranty shall be cause for cancellation or rescission of the contract of sale of any product or accessory. In no event recovery of any kind be greater than the amount of the purchase price of the product sold.

This warranty gives you specific legal rights. You may also have other rights, which vary from state to state.

TABLE OF CONTENTS

	PAGE
INTRODUCTION	2
SAFETY PRECAUTIONS	3
SAFETY DECALS	5
ASSEMBLY	
Tools Required	6
Installing the Chute	7
Installing the Snowblower Drive System	7
Adjusting the Height of the Engine Support	8
Positioning the Engine	9
Installing the Guard	9
Installing the Electromagnetic Clutch	10
Installing the Electrical Wiring	11
Installing the Belt	12
Vehicle Preparation	13
Preparing the Subframe	15
Installing on the Vehicle	17
OPERATION	
Lifting and Lowering the Snowblower	20
Snowblowing Technique	21
Adjusting the Pressure of the Subframe Tires on the Ground	21
Skid Shoe adjustment	21
MAINTENANCE	
Engine Maintenance	22
Snowblower Maintenance	22
Clearing a Clogged Chute	22
Cutting Edge Maintenance	22
Lubrication	23
Auger and Fan Shear Bolt Replacement	23
Belt Replacement	24
Replacing the Augers, Fan and / or Gear Box	25
DISMOUNTING & STORAGE	26
TROUBLESHOOTING	27
PARTS BREAKDOWN AND PARTS LIST	
48" Snowblower.....	29
54" Snowblower	32
Chute	35
Subframe	37
Snowblower with Kohler 14Hp motor	39
Snowblower with Kohler 20Hp motor	41
Snowblower with Kohler 23Hp motor	44
54" Prestige Snowblower 700360-10	47
Parts Explosive view	50
TORQUE SPECIFICATION TABLE	51
OPTIONS	53

INTRODUCTION

TO THE PURCHASER

This new accessory was carefully designed to give years of dependable service. This manual has been provided to assist in the safe operation and servicing of your attachment.

NOTE: All photographs and illustrations in the manual may not necessarily depict the actual models or attachment, but are intended for reference only and are based on the latest product information available at the time of publication.

Familiarize yourself fully with the safety recommendations and operating procedures before putting the machine to use. Carefully read, understand and follow these recommendations and insist that they be followed by those who will use this attachment.



THIS SAFETY ALERT SYMBOL IDENTIFIES AN IMPORTANT SAFETY MESSAGE IN THIS MANUAL THAT HELPS YOU AND OTHERS AVOID PERSONAL INJURY OR EVEN DEATH. DANGER, WARNING, AND CAUTION ARE SIGNAL WORDS USED TO IDENTIFY THE LEVEL OF HAZARD. HOWEVER, REGARDLESS OF THE HAZARD, BE EXTREMELY CAREFUL.

DANGER: Signals an extreme hazard that will cause serious injury or death if recommended precautions are not followed.

WARNING: Signals a hazard that may cause serious injury or death if the recommended precautions are not followed.

CAUTION: Signals a hazard that may cause minor or moderate injury if the recommended precautions are not followed.

Record your attachment serial number and purchase date in the section reserved below (there is no serial number on the subframe). Your dealer requires this information to give you prompt, efficient service when ordering replacement parts. Use only genuine parts when replacements are required.

If warranty repairs are required please present this registration booklet and original sales invoice to your selling dealer for warranty service.

This manual should be kept for future reference.

Please check if you have received all the parts for your kit with the list of the bag and the list of the box.

SERIAL NUMBER : _____
(IF APPLICABLE)

MODEL NUMBER: _____

PURCHASE DATE : _____

O/L = Obtain Locally



SAFETY PRECAUTIONS



Careful operation is your best insurance against an accident. Read this section carefully before operating the vehicle and accessory. This accessory is capable of amputating hands and feet and throwing objects. Failure to observe the following safety instructions could result in serious injury. All operators, no matter how experienced they may be, should read this and other manuals related to the vehicle and accessory before operating. It is the owner's legal obligation to instruct all operators in safe operation of the accessory.

GLOSSARY:

In this manual, right and left sides are determined by sitting on the seat of the vehicle facing forward.

In this manual, "accessories" means attachments (snowblower, rotary broom, blade etc.) that you install on the vehicle (lawn tractors, A.T.V. s etc).

TRAINING:



This symbol, "Safety Alert Symbol", is used throughout this manual and on the accessory's safety labels to warn of the possibility of serious injury. Please take special care in reading and understanding the safety precautions before operating the vehicle and accessory.

1. Read this owner's manual carefully. Be thoroughly familiar with the controls and proper use of the vehicle and accessory. Know how to stop the unit and disengage the controls quickly.
2. Never allow children to operate the vehicle nor the accessory. Never allow adults to operate the vehicle nor the accessory without proper instructions.
3. No one should operate the vehicle nor the accessory while intoxicated or while taking medication that impairs the senses or reactions.
4. Keep the area of operation clear of all people, particularly small children and pets.

PREPARATION:

1. Thoroughly inspect the area where the accessory is to be used and remove door mats, all foreign objects and the like.
2. For motorized accessories, disengage all clutches and shift into neutral before starting engine.
3. Do not operate the accessory without wearing adequate winter outer garments. Avoid loose fitting clothing that can get caught in moving parts. Wear footwear that will improve footing on slippery surfaces.

4. Handle fuel with care, it is highly flammable.

- a) Use approved fuel container.
 - b) Never add fuel to a running engine or hot engine.
 - c) Fill fuel tank outdoors with extreme care. Never fill fuel tank indoors.
 - d) Never fill containers inside a vehicle, or on a truck or a trailer bed with a plastic liner. Always place containers on the ground, away from your vehicle, before filling.
 - e) When practical, remove gas-powered equipment from the truck or trailer and refuel it on the ground. If this is not possible, then refuel such equipment on a trailer with a portable container, rather than from a gasoline dispenser nozzle.
 - f) Keep the nozzle in contact with the rim of the fuel tank or container opening at all times, until refueling is complete. Do not use a nozzle lock-open device.
 - g) Replace fuel cap securely and wipe up spilled fuel.
 - h) If fuel is spilled on clothing, change clothing immediately.
5. Never attempt to make any adjustments while the engine (motor) is running (except when specifically recommended by manufacturer).
 6. Let the vehicle and accessory adjust to outdoor temperatures before using.
 7. Never use an accessory without proper guards, plates, or other safety protective devices in place
 8. Always make sure to wear the appropriate safety equipment required (glasses, muffs, mask...) for each type of product. See operation section.
 9. Always make sure of having safe traction on the vehicle by using the recommended accessories (chains, A.T.V. tracks, counterweights...). See operation section.
 10. Always make sure the all components are correctly installed. (driveline securely attached and locked at both ends, belts properly installed...)
 11. Always handle the winch cable with thick leather gloves.
 12. **Never modify the accessory or any part without the written consent from the manufacturer.**



SAFETY PRECAUTIONS



OPERATION:

1. Do not put hands or feet near, under or inside rotating parts.
2. Exercise extreme caution when operating on or crossing gravel drives, walks or roads. Stay alert for hidden hazards or traffic. Do not carry passengers.
3. After striking a foreign object, stop the engine (motor), disconnect the wire from the spark plug(s) and keep wire away to prevent accidental starting. Thoroughly inspect the accessory for any damage and repair damage before restarting and using the accessory.
4. If the unit should start to vibrate abnormally, stop the engine (motor) and check immediately for the cause. Vibration is generally a warning of trouble.
5. Take all possible precautions when leaving the vehicle unattended. Disengage the power take-off, lower the attachment, place the transmission into neutral, set the parking brake, stop the engine and remove the contact key.
6. Do not run the engine indoors, except when starting the engine and for transporting in or out of the building. Do not operate or let motor run in a storage area without ventilation because gas contains carbon monoxide which is odorless, colorless and can cause death.
7. Never use the accessories across the face of slopes, go from top to bottom. Exercise extreme caution when using equipment on slopes. Do not attempt to clear a steep slope.
8. Never tolerate bystanders in the working zone. Never use an accessory in the direction of bystanders, it might throw gravel or debris that can hurt people or damage property.
9. Never operate the accessory at high transport speeds on slippery surfaces. Use care when backing up.
10. Do not carry passengers.
11. Disengage power to the accessory when it is transported or not in use.
12. Never operate the accessory without good visibility or light.
13. Keep the accessory away from heat sources or flames.
14. Never handle the winch cable or hook while in tension.

MAINTENANCE AND STORAGE

1. When cleaning, repairing or inspecting the vehicle and accessory, make certain that all moving parts have stopped. For gasoline engine, disconnect wire from the spark plug(s) and keep wire away to prevent accidental starting.
2. Check all the bolts and components at frequent intervals to make sure that they are properly tightened.
3. Never store a motorized accessory with fuel in the fuel tank inside a building where ignition sources are present such as hot water and space heaters, clothes dryers, and the like. Allow the engine to cool before storing in any enclosure.
4. Always refer to the owner's manual when you store the accessory and vehicle for a prolonged or an unspecified length of time.
5. Maintain or replace safety and instruction labels, as necessary.
6. For winter accessories, (if applicable), let the engine run for a few minutes after clean snow in order to prevent the rotary parts from freezing.
7. Inspect the vehicle's and accessory's air filter (if applicable) every day. Clean it or replace it as necessary. Change the oil more often when working in dusty conditions. See the vehicle's and accessory's owner's manual.









**THIS SYMBOL MEANS
DANGER !
BECOME ALERT !
YOUR SAFETY IS INVOLVED !**



SAFETY DECALS



REPLACE IF DECALS ARE DAMAGED
SEE PARTS BREAKDOWN FOR DECAL LOCATION

Symbol	Description
Decal #105126 	To avoid serious injury: Keep hands, feet & clothing away from rotating auger while engine is running.
Decal #105127 	To avoid serious injury: Keep hands out of this discharge chute while engine is running.
Decal #105128 	To avoid serious injury: Keep hands, feet & clothing away. Do not attempt to install or remove drive belt without reading owner's manual.
Decal #105130 	Before installing or using: Locate, read and make sure to understand all of the owner's manual.
Decal #105131 	Refer to owner's manual about wearing safety glasses, ear muffs and mask. Refer to owner's manual for use of counter weights, cat tracks and tire chains.
	1-Do not drive faster than 3 KM/H when the snowblower is in operation. 2-Do not drive faster than 10 KM/H when the snowblower is in the raised position. 3-The head of the snowblower weighs 96 kg. (without engine). 4-The engine wattage. (See specification of the engine installed). 5-The sound pressure level (See specification of the engine installed).

ASSEMBLY

ASSEMBLY INSTRUCTIONS

IMPORTANT: UNLESS OTHERWISE SPECIFIED TORQUE ALL BOLTS ACCORDING TO TORQUE SPECIFICATION TABLE (SEE TABLE OF CONTENTS) WHEN STATED: TIGHTEN FIRMLY. REFER TO PARTS BREAKDOWN SECTION FOR PART IDENTIFICATION.

IMPORTANT: THE VEHICLE MUST BE EQUIPPED WITH A TOW HITCH BALL OF 1 7/8" IN ORDER TO INSTALL THE SNOWBLOWER.

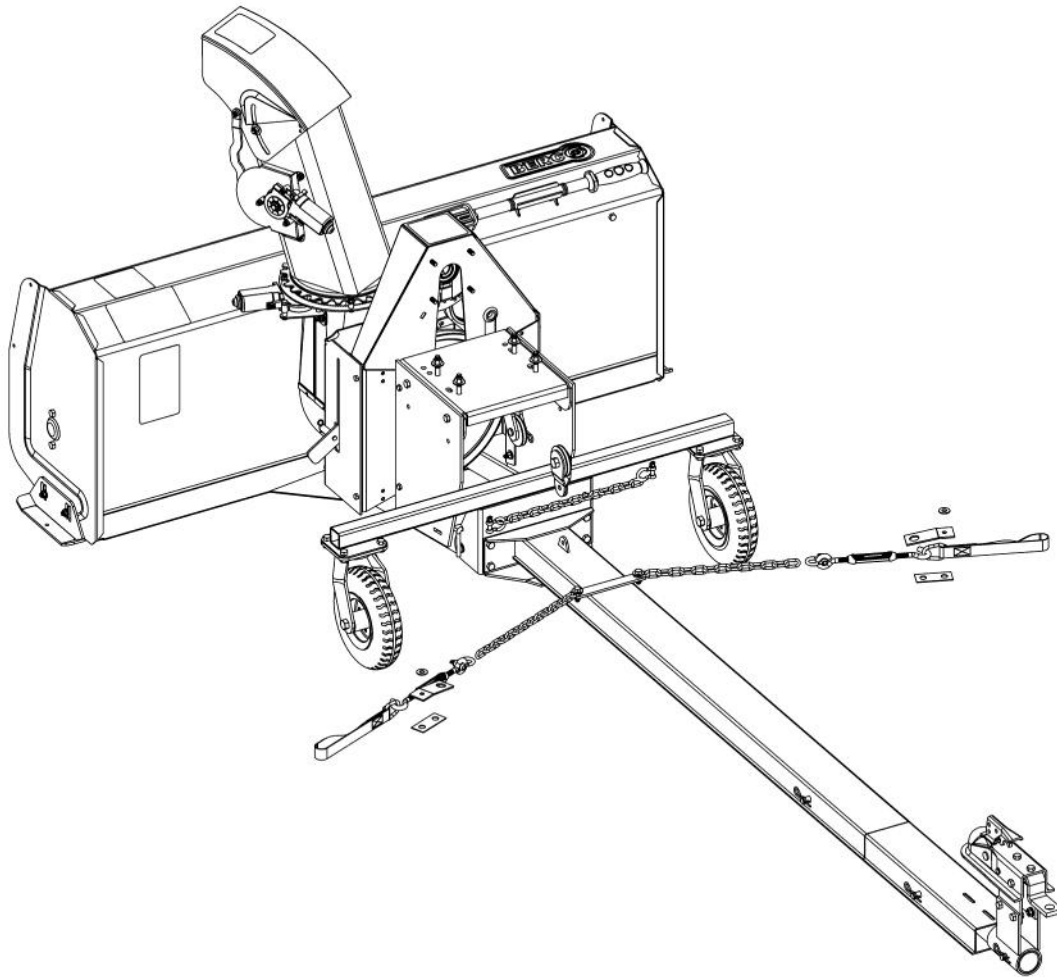

Overall view of the snowblower

TOOLS REQUIRED

- 1 Ratchet
- 4 Wrenches 7/16", 1/2", 9/16" and 13 mm
- 4 Sockets 7/16", 1/2", 9/16" and 13 mm
- 1 Plier
- 1 Cutting pliers
- 1 torque spanner

ASSEMBLY

NOTE: For a snowblower already equipped with a motor, please go to section "vehicle preparation".

INSTALLING THE CHUTE

1. If the muffler of the motor that is being installed on the snowblower surpasses the front face of the motor of 3" (ex: Honda GX630), you must inverse the rotation ring and place as shown below. In doing so, you will avoid contact between the chute and the muffler. Tighten nuts firmly.

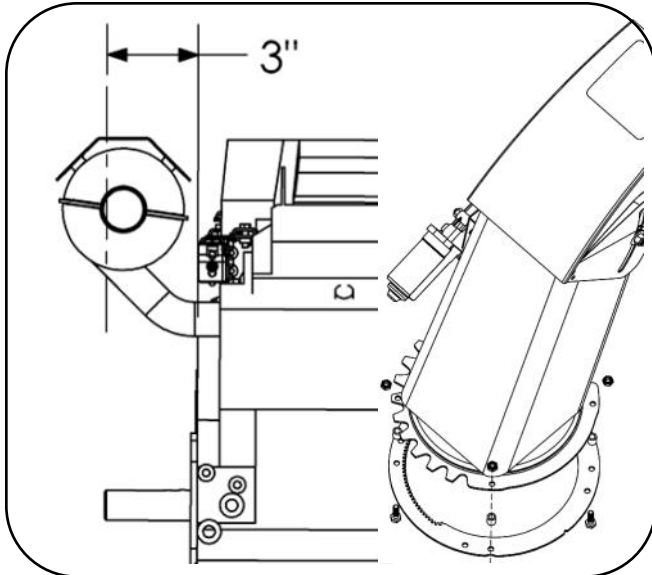

Verification of muffler obstruction

2. Install the rotation ring (**item 1**) over the opening (**item 2**) by aligning the notches. Place the chute (**item 3**) as shown in figure below. Turn the chute a half turn to lock into place.

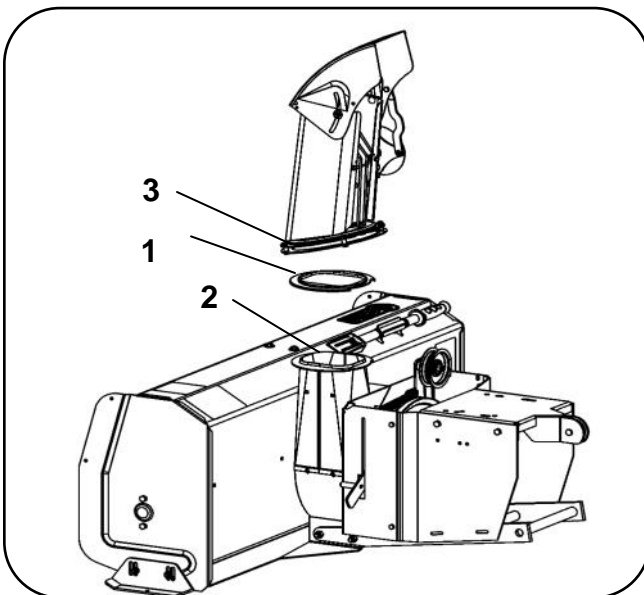

Chute installation

3. Insert the two carriage bolts 1/4" n.c. x 1" (**item 1**) inside the chute as shown in figure below. Insert the gear pin (**item 2**) in the hole on the support (**item 3**) and insert the support and motor assembly (**item 4**) on the carriage bolts. Secure in place with two flange nuts 1/4" (**item 5**).

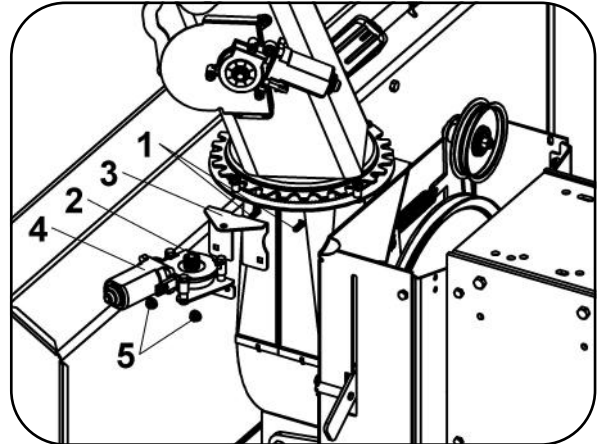

Motor installation

INSTALLING THE SNOWBLOWER'S DRIVE SYSTEM



IMPORTANT



In order to respect the safety precautions concerning the Versatile Plus snowblower, it is imperative to install an engine with an electric starter.

IMPORTANT: Make sure to follow the safety precautions of the engine installed and all its maintenance procedures in the owner's manual.

NOTE: For the Versatile Plus snowblower, Bercomac Limitée recommends installing an engine between 14 and 23 H.P. with a horizontal shaft of 1" or 1 1/8". Here are a few engines that were tested:

Brand	All-Power	Honda	Kohler	
Model	420 CC	GX630 RQXF6	CH-440- 3021sp	Ch-680- 3054
Power	15 C.V.	20 C.V.	14 C.V.	23 C.V.
Shaft	1"	1"	1"	1 1/8"
Muffler		VHLM3		
Gas tank	Includ.	Not includ.	Includ.	Not Includ.
Electric clutch assembly	106178	106178	106178	106179

ASSEMBLY

ADJUSTING THE HEIGHT OF THE ENGINE SUPPORT

NOTE: Adjusting the height of the engine support is very important for the good working order of the snowblower's drive system.

1. Measure the height (**h**) from the middle of the engine shaft to its base (figure below).

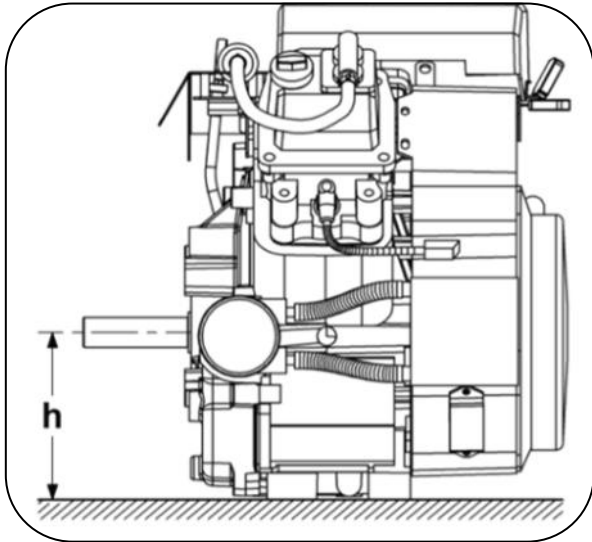

Height of the engine shaft

NOTE: An appropriate choice of holes (**A** or **B**) will respect a distance of 13 5/8" (321mm) between the middle of the engine shaft and the middle of the gear box shaft.

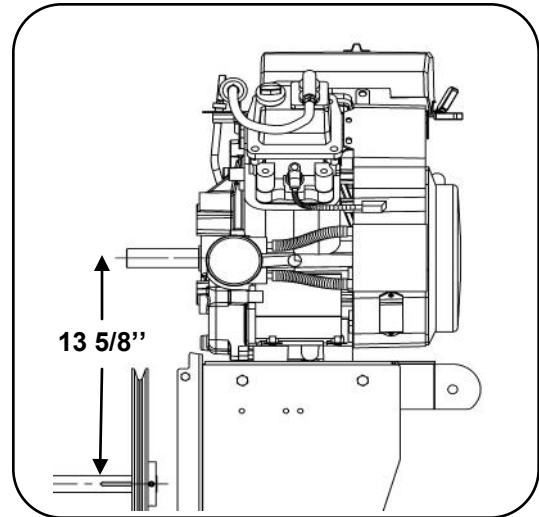

Height of the engine shaft

2. Align the holes (**A** or **B**) of the engine support (**item 1**) with the holes of the hitch (**item 2**). If the height (**h**) of the engine shaft is about 6 1/4" (160mm) use the holes **B**, if the height (**h**) of the engine shaft is about 5 3/8" (135mm) use holes **A**. Insert four hex bolts 3/8" x 1" (**item 3**) in the aligned holes and secure everything in place with four nylon insert lock nuts 3/8" (**item 4**).

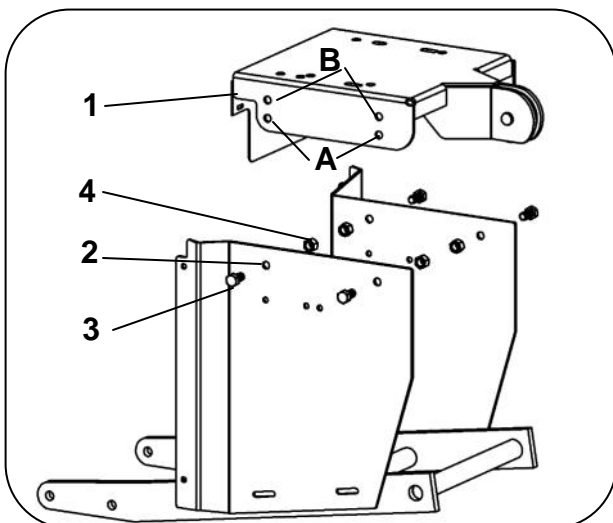

Height of engine support

ASSEMBLY

POSITIONING THE ENGINE

The figure below shows the position of the back right hand hole on the four engines tested. If another engine is installed on the snowblower, all you have to do is attach the engine with the right combination of holes to allow an adequate pulley alignment. The GX630 has two series of holes in back. Use the series of holes closest to the engine's shaft. This will provide an adequate pulley alignment.

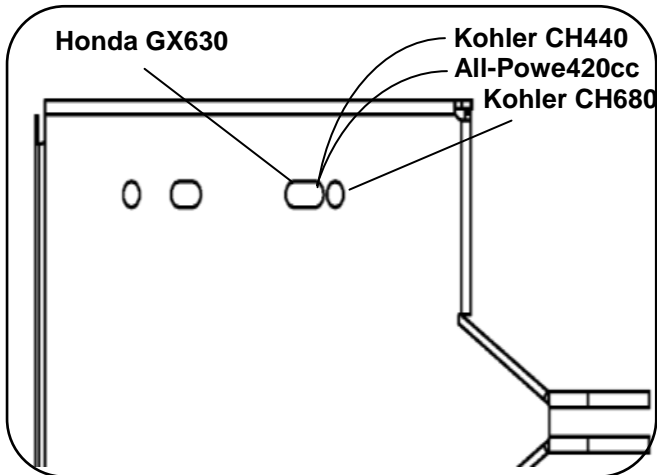

Positioning the engine

Position the engine (**item 1**) on the engine support (**item 2**) making sure to use the right combination of holes. Secure engine in place with four hex bolts 3/8" x 2" (**item 3**), eight flat washers 7/16" (**item 4**) and four nylon insert lock nuts 3/8" (**item 5**). **Tighten firmly.**

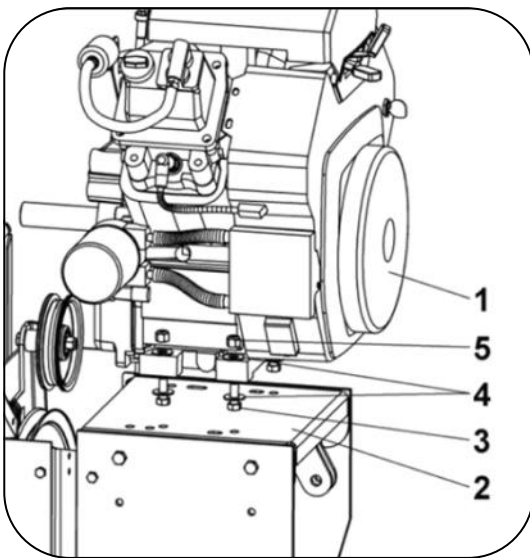

Install the engine

ENGINE PREPARATION:



CAUTION



Oil must be added to this motor.

Please refer to motor's owner's manual for instructions and proper winter oil recommendations.

INSTALLING THE GUARD

For this step two types of bolts are supplied: hex bolt 5/16" x 3/4" n.f. and hex bolt M8 x 1.25 x 20. Use the bolts that correspond with the engine installed. Secure the guard (**item 1**) on the engine (**item 2**) with four hex bolts (**item 3**).

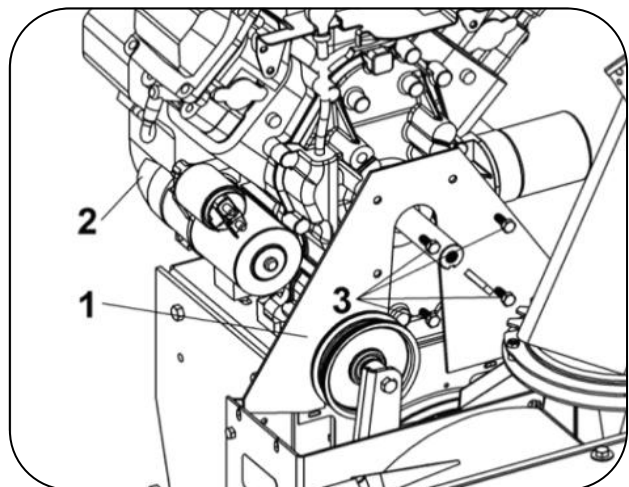

Installing the guard

ASSEMBLY

INSTALLING THE ELECTROMAGNETIC CLUTCH

NOTE: If the position of the electromagnetic clutch is not well adjusted, it can have important repercussions on the life span of the snowblower components and on its efficiency.

Here is a chart identifying the mounting components of the electromagnetic clutch according to the engines tested.

Brand	All-Power	Honda	Kohler	
Model	420cc	GX630 20cv	CH440 14cv	CH680 23cv
Clutch assembly	106178	106178	106178	106179
Clutch spacer (Item 1 or 2 or 3)	106616 (3) 1/4" th. *See Note	106584 (1) 3/4" th. 106338 (2) 1/8" th. *See note	106338 (2) 1/8" th. *See note	106216 3/4" th. *See note
Clutch (item 4)	106142	106142	106142	106143
Clutch support (item 5)	103976	103976	103976	106277
Bolt (item 6)	7/16" x 1 1/2" n.f.	3/8" x 2 n.f.	3/8" x 1 1/2" n.f.	7/16" x 1 1/2" n.f.
Torque*	40 - 45 ft-lb	40 - 45 ft-lb	40 - 45 ft-lb	50 - 55 ft-lb

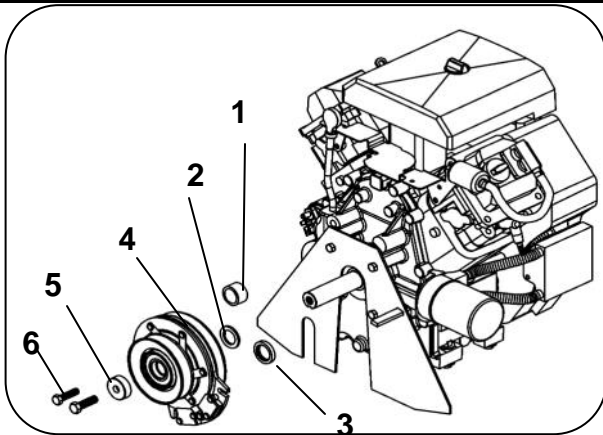

Mounting components of the electromagnetic clutch

Install the clutch on the engine shaft as shown in **figure above**, making sure to respect the torque specified in the chart above.

NOTE: Hold the clutch support with a lock-grip plier which will keep the engine shaft from turning and to obtain the appropriate torque.

*****NOTE:** You may need to add a spacer between the clutch and the existing spacer or even changing this spacer. This is related to the tolerances of different components. Most importantly, is that the pulleys are aligned.

Take note, for the All Power motor, the clutch spacer (item 3) 106616 must be applied on the motor. Putting any other spacer instead, may cause failure.

NOTE: Once the clutch has been installed, it is important to check the alignment of the two pulleys (Clutch pulley **(item 1)** and snowblower pulley **(item 2)**). The clutch 106143 has two grooves to position the belt. You must use the one closest to the engine. The two **following figures** illustrate two types of wrong pulley alignments. A wrong pulley alignment can be resolved by loosening the bolts securing the engine and moving the engine. If this is the case, it is very important to retighten all the bolts.

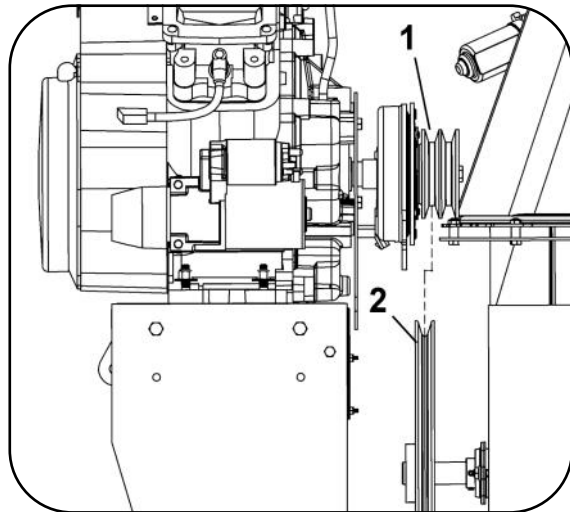

Parallel pulley alignment error

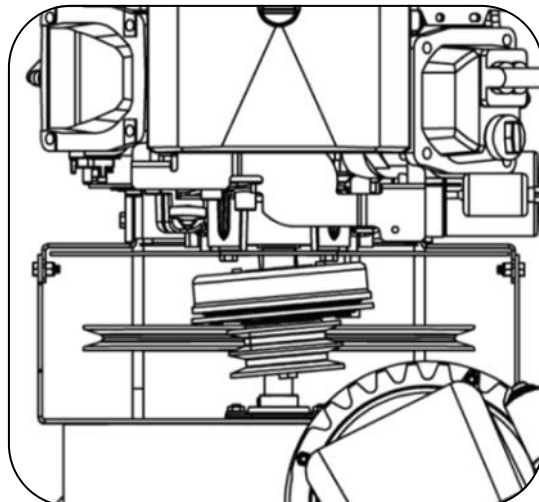

Angular pulley alignment error

ASSEMBLY

INSTALLING THE ELECTRICAL WIRING

IMPORTANT: Improper installation of the electrical wiring might cause damage to the snowblower components.

When assembling the snowblower there are four elements to connect: the electromagnetic clutch, the engine's kill switch, the control of the engine's electric starter and connect the engine power supply.

1. Find wire 106548 (**item 1**). Pass wire around arm blocking rotation of clutch (**item 2**) and connect it to the electromagnetic clutch (**item 3**). Secure wire in place with a nylon tie wrap (**item 4**). Shorten tie wrap to make sure the wire never comes into contact with the pulleys or belt.

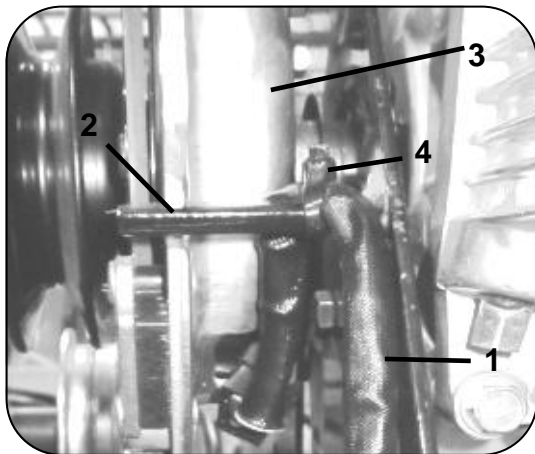

Connect wire to electromagnetic clutch

2. Locate connectors of wiring 104018 and 106558. Connect red wires to the engine's starter (solenoid) and the black wires to the base of the motor as shown.

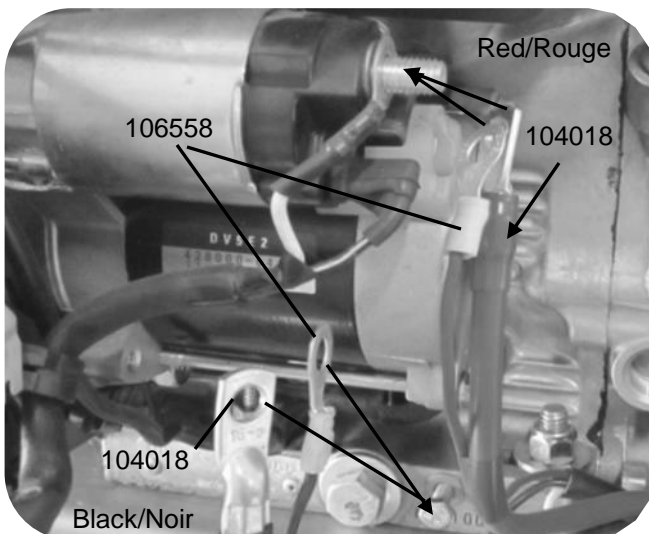

Connect power cables

3. Locate orange and green wiring of the 106558 and cable going to engine starter and solenoid. Connect as illustrated.

IMPORTANT: This step is essential since it will prevent the snowblower from being accidentally started.

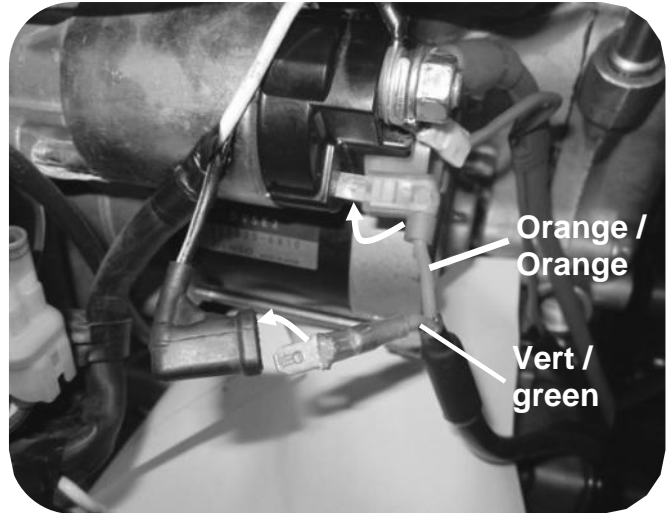

Connect cables of engine starter

4. Locate the wire of oil sensor (**item 1**) on the engine and disconnect it. Connect the control box wire connector (**item 2**) to the engine wire (**item 1**) connector (**item 3**). Connect the control box wire (**item 4**) connector (**item 5**) to the engine wire (**item 1**).

Note: The kill switch must be pulled up to start the snowblower engine.

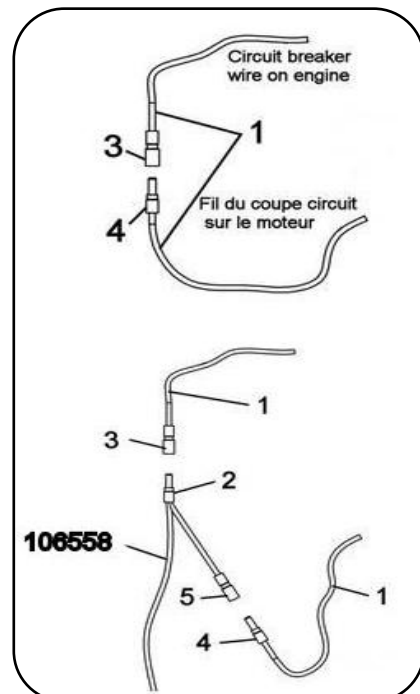

Connecting the engine circuit breaker wire

ASSEMBLY

INSTALLING THE BELT

1. Install the belt (**item 1**) on the clutch pulley groove (**item 2**) closest to the engine (**item 3**) and on the snowblower V pulley (**item 4**).

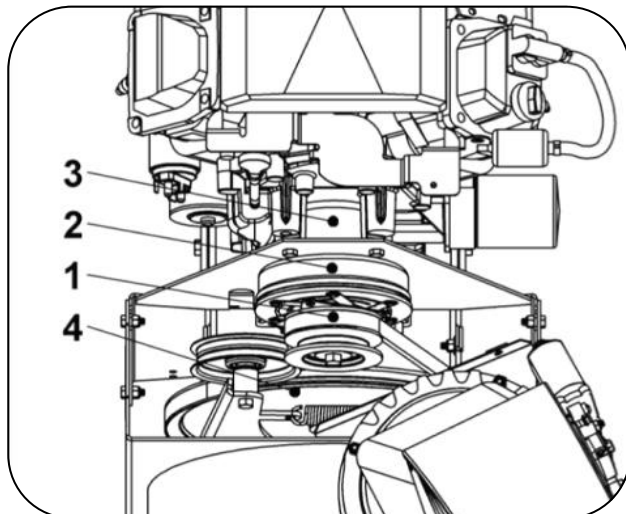

Positioning the belt

2. Lower the tensioner (**item 1**) and place it in the notch on the frame (**item 2**). Make sure the flat pulley is well placed on the belt.

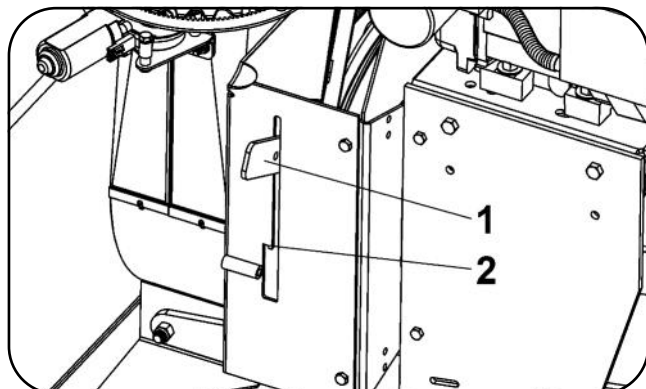

Tensioning the belt

3. Secure the tensioner (**item 1**) with the pin (**item 2**) and hair pin (**item 3**).

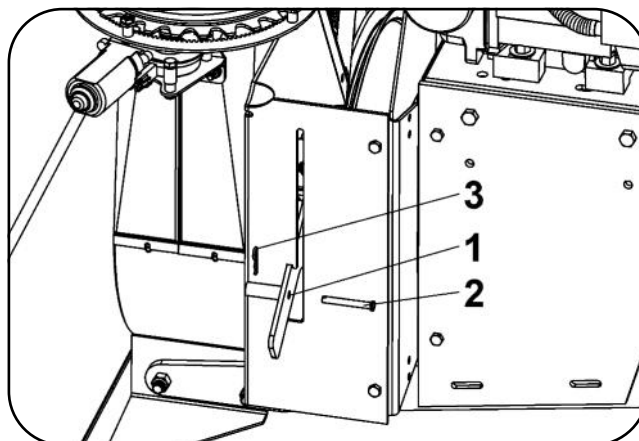

Securing the tensioner

INSTALLING THE BELT GUARD

Place the belt guard (**item 1**) on the snowblower frame (**item 2**). Secure everything in place with three hex bolts 1/4" x 1/2" (**item 3**) three lock washers 1/4" (**item 4**) and three flat washers 5/16" (**item 5**)

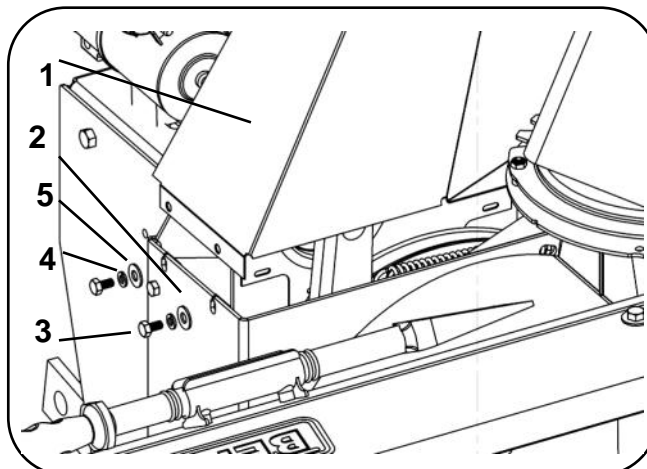

Installing the belt guard

ASSEMBLY

VEHICLE PREPARATION

FASTENING THE SUBFRAME

Choose one of the three following options as a means of fastening the subframe.

OPTION A:

Install the lift strap (**item 1**) by making a loop around the front suspension arm of the vehicle. Tighten the loop firmly.

OPTION B:

Remove the nut and bolt from the vehicle's front suspension arm. Secure the bracket (**item 3**) with a bolt, flat washer and nut (**item 2**). Do not tighten the nut too firmly.

OPTION C:

Remove the nut and bolt from the vehicle's front suspension arm. Secure the bracket (**item 4**) with a bolt, flat washer and nut (**item 2**). Do not tighten the nut too firmly.

NOTE: Repeat the operation on the other side of vehicle.

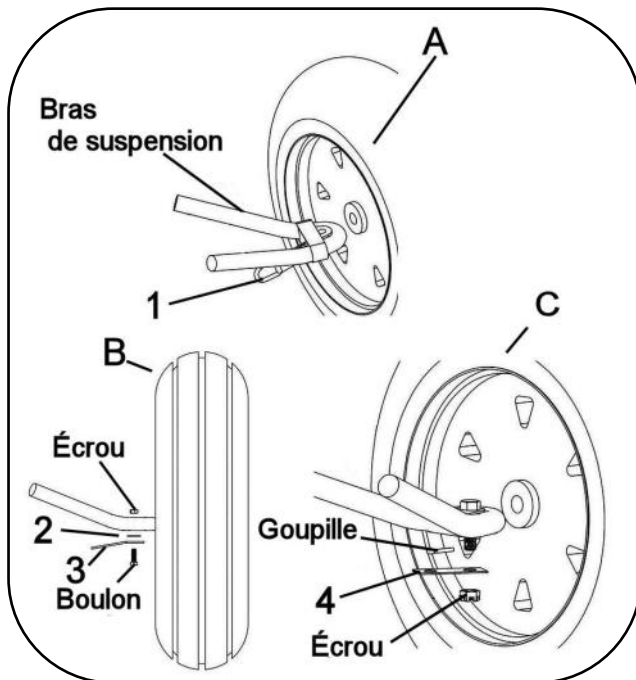

Vehicle preparation

CONTROL BOX INSTALLATION.

1. Choose between the two different ways of securing the control box support (**item 1**).

Option A

Use two hex bolts 1/4" x 1 1/2" (**item 2**), two spacers (**item 3**) and two flange nuts 1/4" (**item 4**) in order to secure the control box support to the support brackets. (**item 5**).

NOTE: Choose the right combination of holes on the control box support so that the front of the control box is facing the front of the vehicle.

Option B

Use the support as a template and drill two holes in an appropriate place on the vehicle.

Secure the control box support with two bolts 1/4" x 1/2" (**item 6**) and two flange nuts 1/4".

2. Insert the control box (**item 7**) in the control box support.

NOTE: In order to avoid damages due to water accumulation, make sure the control box is installed horizontally.

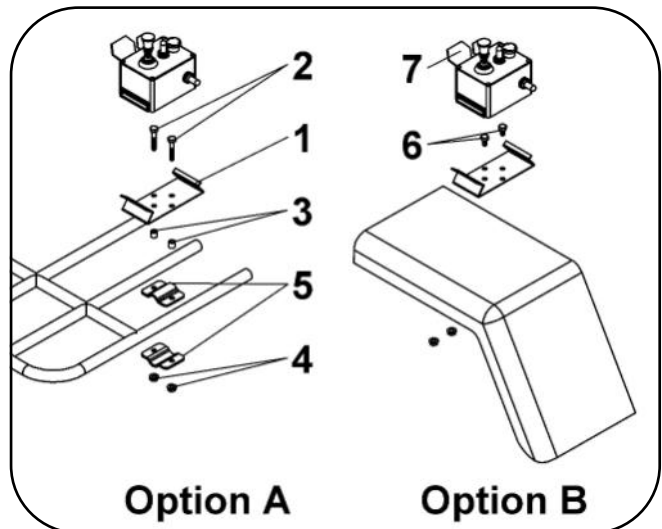

Installing the control box

ASSEMBLY

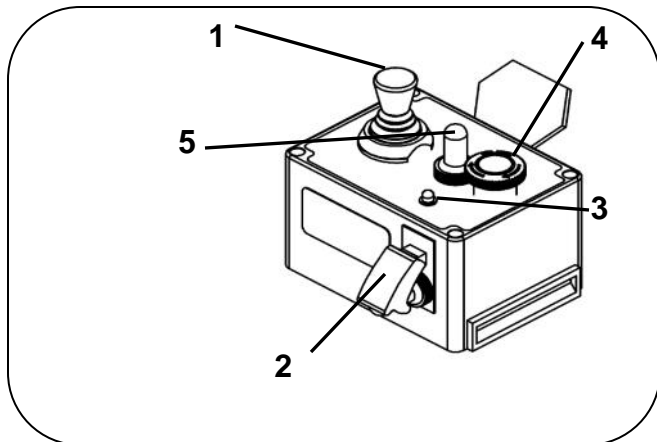

Control box

Item 1: The 4 positions switch that controls the chute deflector and rotation.

Item 2: P.T.O. switch

Item 3: Light indicator for P.T.O.

Item 4: Kill switch

Item 5: Light switch (if installed)

NOTE: For snowblowers equipped with a saddle

SADDLE PREPARATION:

NOTE: All the electrical system is already installed and connected to the various snowblower components.

Place the saddle assembly on the A.T.V. seat. Place and tie the wire protector in an appropriate place so the wire protector does not interfere with any hot or moving parts

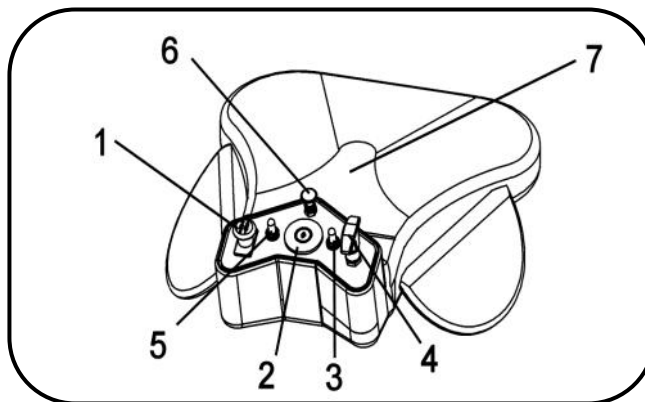

Saddle controls

Item 1: P.T.O. Switch

Item 2: Ignition & Light Switch

Item 3: Switch (deflector)

Item 4: Throttle Control

Item 5: Switch (chute rotation)

Item 6: Choke Control

Item 7: Safety Switch

ASSEMBLY

INSTALLING THE ELECTRICAL SUPPLY

Connect wire assembly (104017) to the positive post on the vehicle's battery. Connect the black wire on the vehicle's frame.

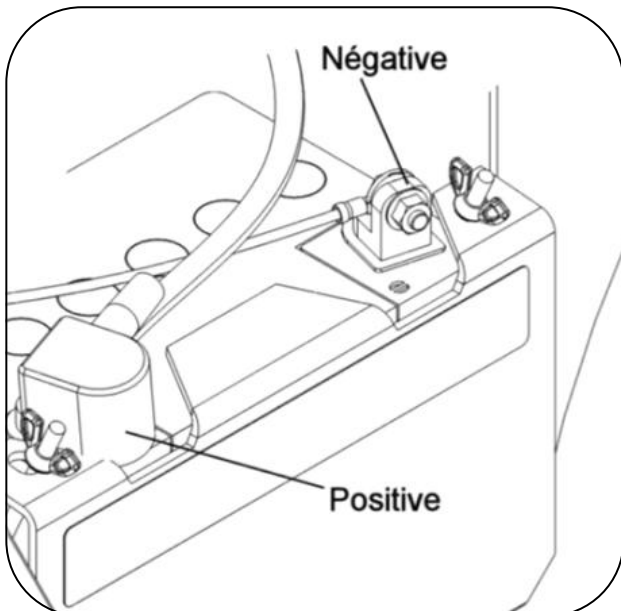

Connect the electrical supply on the vehicle's battery

PREPARING THE SUBFRAME

1. Assemble the wheel support (**item 1**) on the subframe (**item 2**) with four hex bolts $\frac{3}{8}$ " x 1" (**item 3**) four flange nuts $\frac{3}{8}$ " (**item 4**).

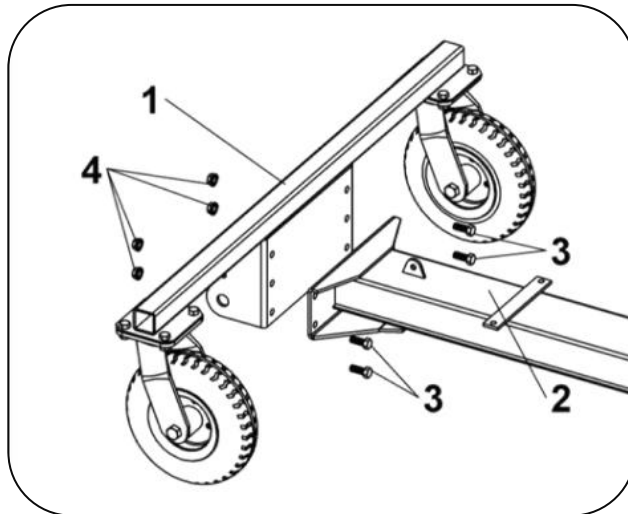

Installing the wheel support

NOTE: The set of holes used to assemble the wheel support to the subframe depends on the height of the vehicle. Once installed the subframe must be parallel with the ground.

2. Install the assembled turnbuckles (**item 1**) on the subframe (**item 2**) with two hex bolts $\frac{5}{16}$ " x 1" (**item 3**), two flat washers $\frac{3}{8}$ " (**item 4**) and two nylon insert lock nuts $\frac{5}{16}$ " (**item 5**). Slightly tighten the nuts.

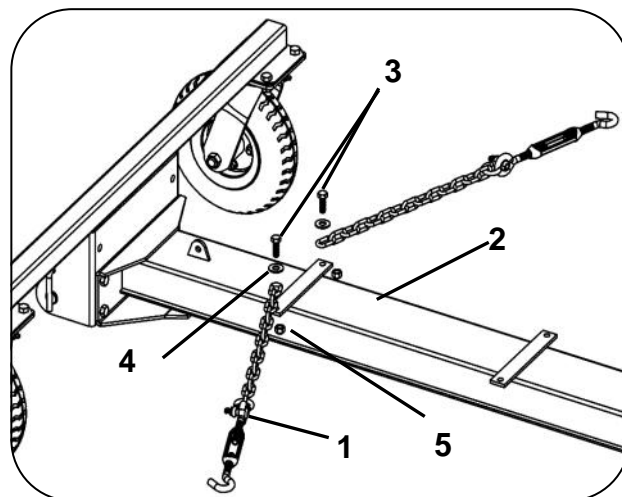

Installing the turnbuckles

ASSEMBLY

3. Among the three following configurations, choose the height of the hitch support. There must be a maximum of ground clearance. (Configuration A) does not have the hitch support plates (**item 1**). If applicable, assemble the hitch support plates on the hitch support (**item 2**) with four hex bolts $3/8"$ x $3/4"$ (**item 3**) and four nylon insert lock nuts $3/8"$. Secure the hitch (**item 4**) on the two hitch support plates or on the hitch support with a hex bolt $3/8"$ x $3"$ (**item 5**) and one nylon insert lock nut $3/8"$. Tighten firmly

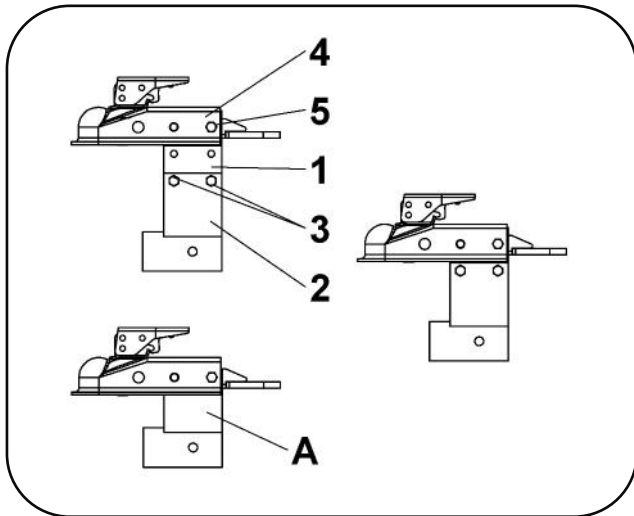

Adjusting the hitch support

4. There are seven different positions on the adjustment tube (**item 1**) (the adjustment tube can be inverted) to adjust the length of the subframe. To choose the right adjustment, insert the adjustment tube into the subframe (**item 2**) and insert the rear bracket (**item 3**) on the adjustment tube. Slide the hitch support (**item 4**) on the rear bracket. Do not secure.

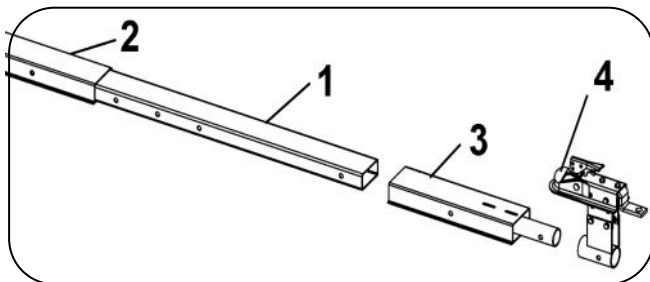

Assembling the subframe

5. Drive the vehicle over the subframe, Place the hitch under the tow hitch ball and make sure there is at least 7" (180 mm) between tube on the wheel support (**item 1**) and the most advance part of the front of the vehicle. Furthermore, the wheels of the subframe must not touch the front wheels of the vehicle.

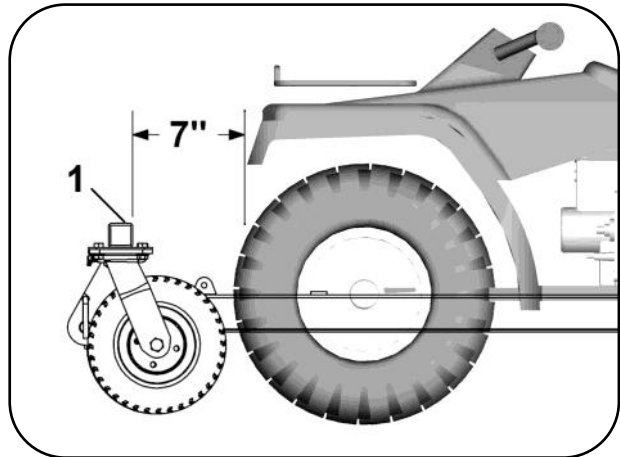

Adjusting the length of the subframe

6. Identify the right length of the subframe (**item 1**) and secure in place with two long pins (**item 2**), a short pin (**item 3**) and three hair pins 3mm (**item 4**).

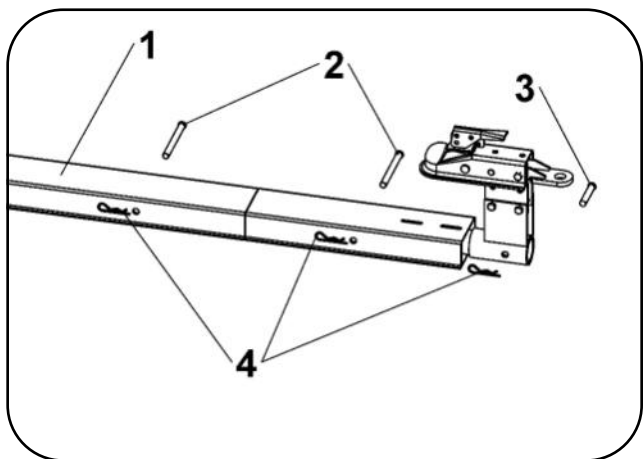

Securing the subframe

ASSEMBLY

INSTALLING ON THE VEHICLE

1. Place the hitch (item 1) on the tow hitch ball and secure in place with a pin (item 2) and a hair pin (item 3).

IMPORTANT: Make sure the vehicle never comes into contact with the subframe even when the vehicle's suspensions are compressed to the maximum.

NOTE: It is possible to turn the hitch support to facilitate driving the vehicle over the subframe.

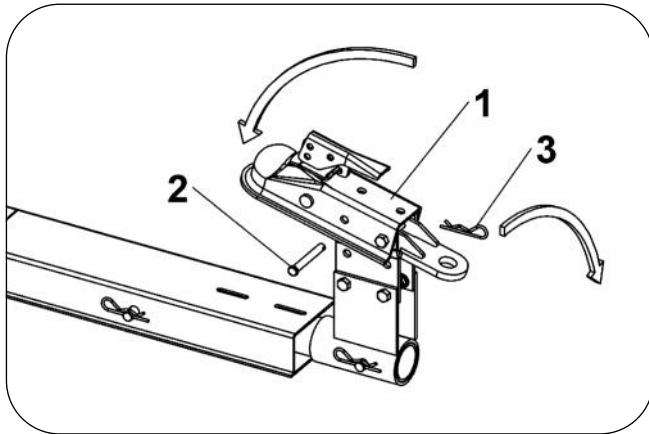

Installing the subframe on the tow hitch ball

Operation instructions for hitch coupler:



WARNING



TO PREVENT INJURIES:

Always check that ball is completely inserted into hitch coupler socket and that under jaw is securely closed around the bottom of ball.

Always check that hitch coupler handle is properly locked before its use.

Always examine hitch coupler and ball for damage before using, replace if damaged.

NOTE: Correct adjustment will allow the handle to be released with moderate pressure applied to the handle.

To open, pull up on hitch coupler handle and rotate forward.

Place hitch coupler on ball.

When ball is completely nested in socket, rotate hitch coupler handle backward until handle is in locked position.

Always check tightness before using the tow hitch.

Lock the handle (item 1) into position over the ball in the hitch coupler. Tighten the lock nut (item 2) against the spring so that the hitch coupler is not loose on the ball.

Be sure hitch coupler handle is in locked position.

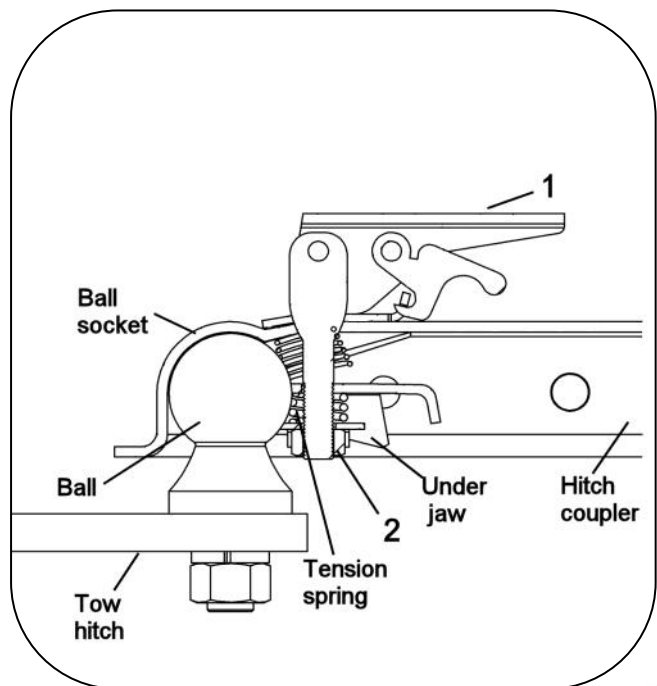

Adjusting the hitch coupler

ASSEMBLY

2. In the event where the vehicle is equipped with a prominent front bumper or tracks, the assembled turnbuckles (**item 3**) will become too angled. Relocate the assembled turnbuckles from plate 1 towards plate 2.

IMPORTANT: To avoid any damages to the subframe or vehicle, plate #2 must be placed in front of the wheels' center if the assembled turnbuckles are relocated.

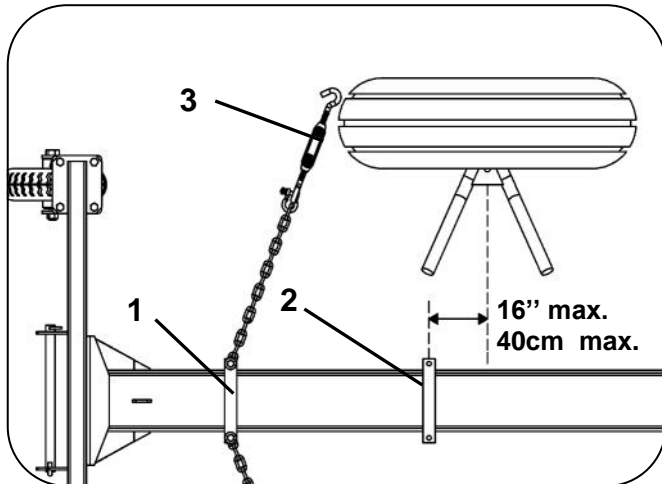

Verification of turnbuckles installation

3. Hook the turnbuckles (item 1) in the brackets or the lift straps. Tighten the turnbuckles firmly.

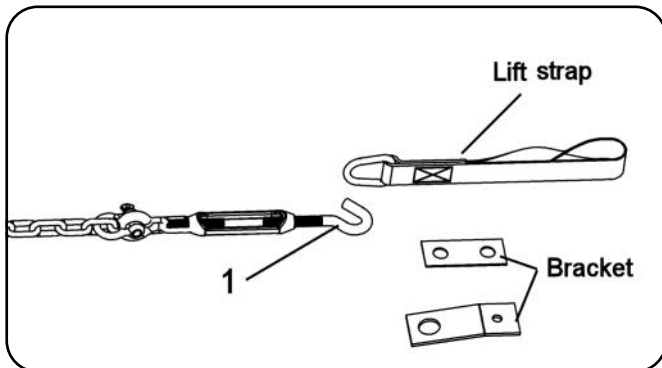

Install the turnbuckles on the vehicle

IMPORTANT: After adjusting the turnbuckles, tighten firmly the nuts that secure the brackets on the vehicle's suspension arms. Make sure to lock the nuts with the original locks. Furthermore, tighten firmly the turnbuckle assembly nuts that secure them to the subframe.

4. Install the snowblower hitch (item 1) on the wheel support (item 2) of the subframe with a pin (item 3) and hair pin 4mm (item 4).

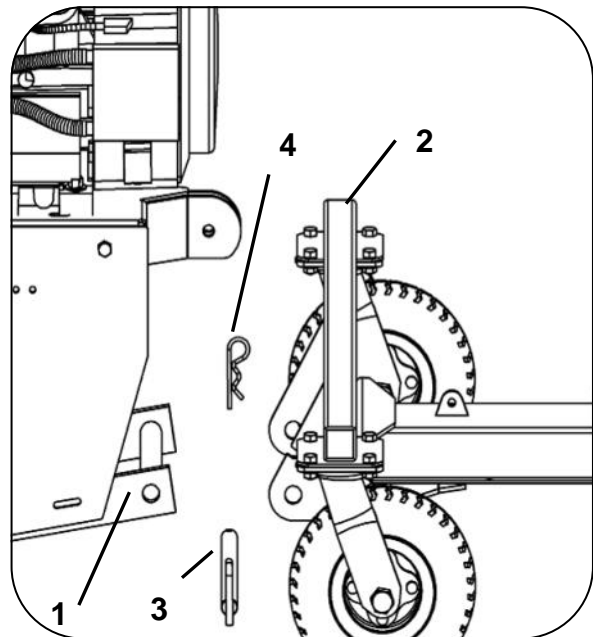

Assembling the snowblower to the subframe

5. Secure the winch hook (item 1) in the lift eye on the hitch (item 2). Place the winch cable (item 3) between the engine support (item 4) and the pulley (item 5). Secure the pulley with a pin (item 6) and a hair pin 3mm (item 7).

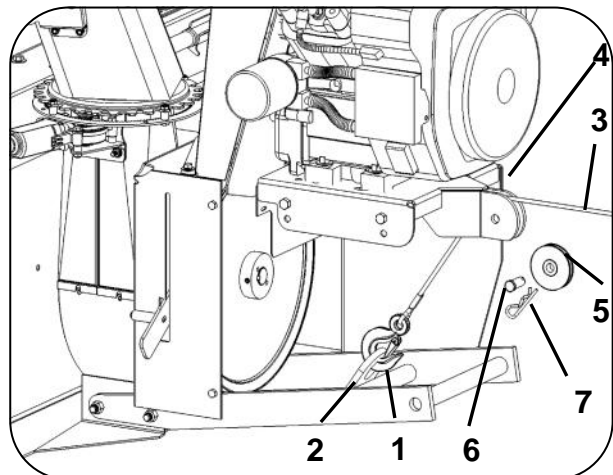

Install the snowblower lift system

ASSEMBLY

6. In the case the winch is not strong enough to lift the snowblower, it is possible to install the lift system as follows:

Attach the lift strap (optional) (**item 1**) to a well anchored part of the vehicle. Secure the winch hook (**item 2**) in the lift strap. Place the winch cable around the pulley (**item 3**). Secure the pulley in place with a pin (**item 4**) and a hair pin (**item 5**).

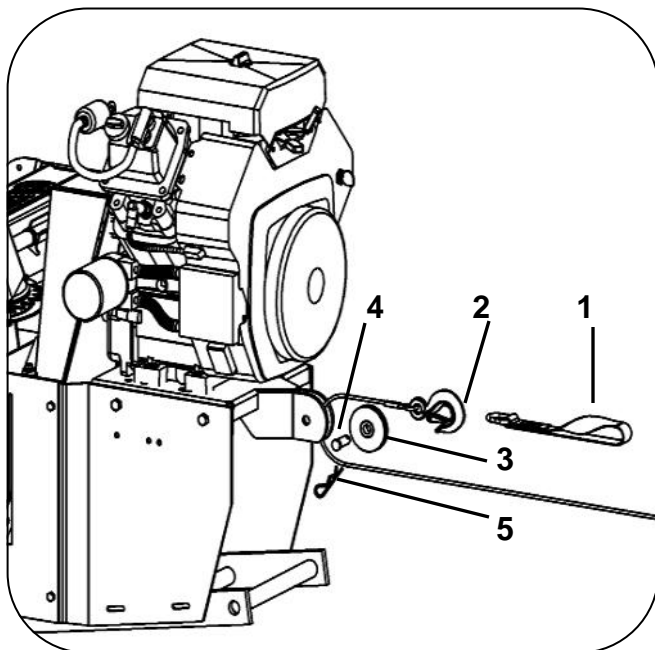

Lift system

7. Connect wiring of snowblower

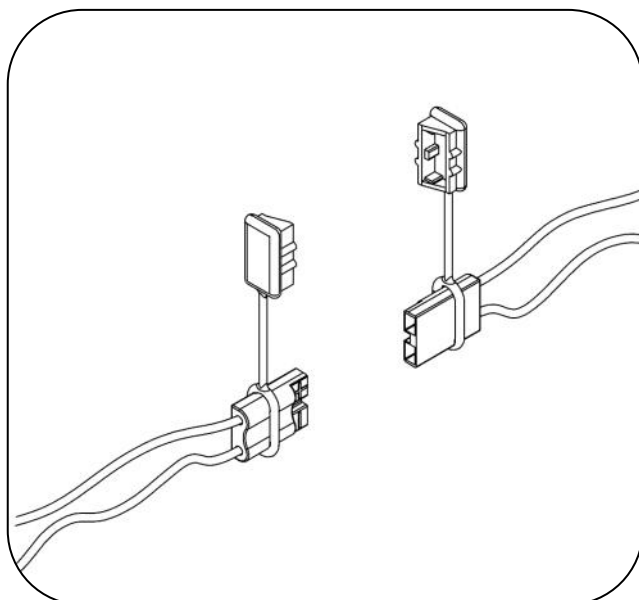

Wire assembly

VERIFYING THE ASSEMBLY

THE LENGTH OF THE SUBFRAME

When the vehicle is advancing in a straight line, make sure the wheels of the subframe do not come into contact with the wheels of the vehicle.

When the snowblower is raised to its maximum, make sure the snowblower engine does not come into contact with the vehicle.

PRESSURE OF THE TIRES ON THE SUBFRAME

Verify and adjust the pressure of the tires of the subframe at 50 psi.

The tire pressure must be even on both sides.

OPERATION



WARNING



Read the vehicle's owner's manual carefully. Be thoroughly familiar with the controls & proper use of the attachment. Know how to stop the unit & disengage the controls quickly.



WARNING



TO PREVENT INJURIES:

Start the engine, engage and disengage the clutch to be sure it functions normally. Make sure the emergency switch is working perfectly. Make sure all the controls are working well.

SNOWBLOWER OPERATION

1. Make sure the snowblower is clear of snow;
2. Make sure the auger and impeller operate freely.
3. Make sure the electromagnetic clutch is deactivated and the kill switch is disengaged.
4. Start the snowblower engine
5. Before activating the electromagnetic clutch, the snowblower engine must run at maximum R.P.M.
6. Operate the snowblower safely.

IMPORTANT: Use full engine r.p.m. when removing wet, sticky snow. low r.p.m. power will tend to plug the chute.

ELECTRICAL CONTROLS

See the "Installation of the control box" section for the identification of the electrical controls of the snowblower.

LIFTING AND LOWERING THE SNOWBLOWER

Use the winch control switch to raise and lower the snowblower.

IMPORTANT: To extend the lifespan of the subframe, immediately release the switch when the accessory hits the stopper in the raised position.

ENGINE OPERATION

Operate the engine according to the instructions in the engine's owner's manual.



WARNING



Never touch with your hands or feet the snowblower's fan, auger or the chute because this is the most frequent cause of accidents associated with snowblowers.



DANGER



Never let the snowblower motor run without all guards in place.



WARNING



To prevent accidents :

- Always use the snowblower in well lighted areas.
- It is essential to install and use a light on the front of the snowblower for night use or in shadowy conditions.



WARNING



To prevent injuries and for more traction when using the snowblower:

- Do not drive faster than 3 km/hr (2 m/hr) with snowblower on the ground.
- Do not drive faster than 10 km/hr (6 m/hr) with the snowblower in raised position.
- Always disengage the electromagnetic clutch when the snowblower is in the raised position.
- Do not operate on a slope greater than 10%.
- Vehicle manufacturer approved tire chains are required.
- Maximum drawbar pull provided for at the hitch ball coupling: 3560N (800 lbs)
- Maximum vertical load provided for on the hitch ball coupling: 360N (80 lbs).
- Ear muffs and safety glasses are recommended.

BURNISHING PROCEDURE

The burnishing procedure must be performed before the first utilisation of the snowblower and after a prolonged period of inactivity. Burnishing the engaging system will ensure proper performance and will help avoid damages.

1. Make sure the fan and the augers are free of any obstruction. Start the motor.
2. Engage electric clutch.
3. Disengage electric clutch and wait for all moving parts to stop.
4. Repeat procedure (steps 2 & 3) 10 times.

OPERATION

SNOWBLOWING TECHNIQUE

When removing snow, do not use the snowblower as a dozer blade to push snow. Allow snowblower to ingest snow at its own speed. If the speed of your A.T.V. is too fast, the snowblower may become overloaded and clogged.



DANGER



DANGER ZONE

It is the snowblower operator's obligation to make sure there are no individuals close by or objects that can be thrown in this zone when the snowblower is running.

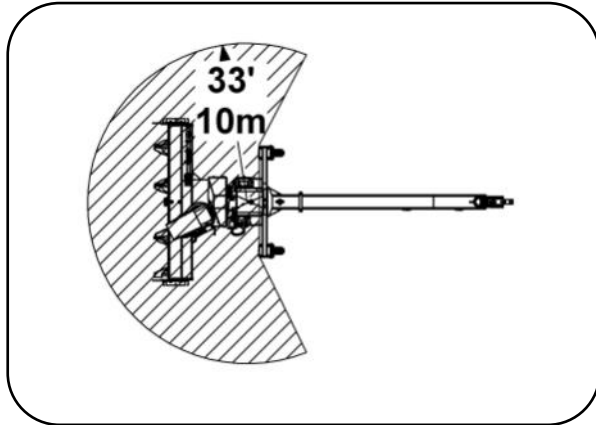

Danger zone

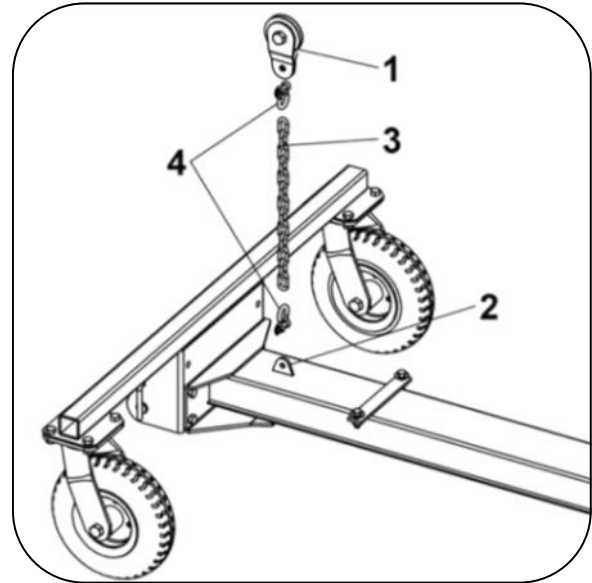

Adjusting the pulley assembly

NOTE: The closer the pulley assembly is to the subframe, less the wheels will dig into the ground; therefore it will be easier to manoeuvre.

NOTE: Make sure you do not compress the vehicle's suspension too much when transferring the weight of the snowblower.

CAUTION: Make sure the subframe does not come into contact with the vehicle.

SKID SHOE ADJUSTMENT

Level paved surface: Adjust skid shoes to allow 3/16" to 1/4" or 5 mm to 7 mm clearance (A) between cutting edge and surface.

Uneven or gravel surface: Adjust skid shoes to allow 1/2" to 5/8" or 13 mm to 16 mm clearance (A) between cutting edge and surface.

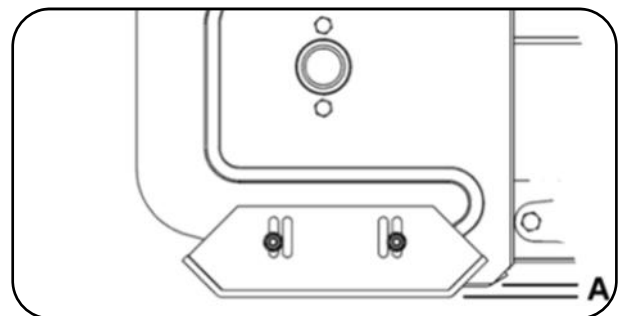

Skid shoe adjustment

ADJUSTING THE PRESSURE OF THE SUBFRAME TIRES ON THE GROUND

When the ground is soft, the vehicle may lose some of its manoeuvrability because the tires on the subframe have a tendency to dig into the ground. In order to avoid this problem, it is possible to install the pulley assembly 106140 (item 1) supplied with the snowblower.

Thread the winch cable through the pulley assembly. Join the pulley to the eye on the subframe (item 2) with the chain (item 3) two shackles (item 4).

MAINTENANCE



WARNING



Before proceeding with any snowblower maintenance, assembling or dismounting:
Apply parking brakes of the vehicle.
Stop the snowblower engine and remove the ignition key
Disconnect the wire from the spark plug(s) and keep away from spark plug(s) to prevent accidental starting.



WARNING



If the snowblower is in the raised position, always verify to provide adequate blocking before working underneath the snowblower.



WARNING



- Do not attempt to clear clogged chute, auger or fan of snow while the snowblower's engine is running.
- Disengage snowblower.
- Lower snowblower onto ground.
- Set the parking brake.
- Stop engine, remove the ignition key, disconnect the wire from spark plug(s) and keep away from spark plug(s) to prevent accidental starting.
- Make sure all moving parts have stopped.
- Do not use hand to unclog chute, use the chute shovel supplied with the snowblower.

ENGINE MAINTENANCE

Maintain the engine according to the instructions in the engine's owner's manual.

SNOWBLOWER MAINTENANCE

Check mounting bolts at frequent intervals for proper tightness in order to prevent costly repairs. Make sure your snowblower is in safe working condition.

PRESSURE OF THE TIRES ON THE SUBFRAME

Verify and adjust the pressure on the tires of the subframe at 50 psi.
The tire pressure must be even on both sides.

SNOWBLOWER PULLEY REPLACEMENT OR ALIGNMENT

Clean the parts before aligning or replacing the pulley. Apply some "Loctite" 2760 on the key and the set screws. Tighten firmly.

CUTTING EDGE MAINTENANCE

Verify from time to time the wearing on the cutting edge to make sure you do not wear out the base of the snowblower's chassis. This cutting edge is reversible. Unscrew the bolts and turn the cutting edge,
Reinstall with new carriage bolts 5/16" x 3/4" grade 5 and new lock nuts 5/16".

CLEARING A CLOGGED CHUTE

Whether it is the snowblower auger, the fan or the chute that is clogged, it is essential to follow these instructions to the letter.

1. Disengage the electromagnetic clutch
2. Lower the snowblower to the ground and apply the vehicle's hand brake;
3. Stop the snowblower engine, remove the key and wait for all the rotating parts to stop turning.
4. Disconnect the wire from the spark plug(s) and keep away from spark plug(s) to prevent accidental starting;

WARNING: Always use the chute shovel supplied with the snowblower in order to unclog the snowblower, **never use your feet or hands.**

MAINTENANCE

LUBRICATION

SUBFRAME WHEELS: Grease the wheel's axles, the fork pivots after every sixteen hours of use. Apply oil at all pivot points.

CHUTE ROTATION SYSTEM: Oil the base of the chute every sixteen hours of operation.

GEAR BOX :

Check the oil annually. If necessary, add AGMA 4 EP or SAE 90 oil.

The gear box should have a total of 275ml of oil or filled to the rim of the bolt hole when installed on the snowblower.

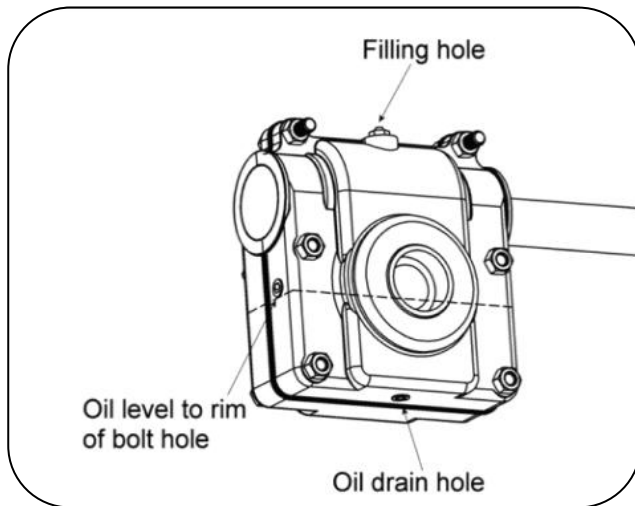

Oil level in the gear box

AUGER AND FAN SHEAR BOLT REPLACEMENT

IMPORTANT: The shear bolts are to be considered a preventive measure and not an assured protection. Operator vigilance is required. Thoroughly inspect the areas where the snowblower is to be used and remove all foreign objects.

TO AVOID DAMAGE TO THE SNOWBLOWER:

Use only the original shear bolts

103999 (**item 1**) for the fan and 104000 (**item 2**) for the auger.

The use of any other shear bolt will not insure any protection and may void the warranty.

IMPORTANT: When replacing the auger shear bolts it is very important to replace the augers in the same position as shown below to avoid damage to the snowblower and to ensure maximum efficiency.

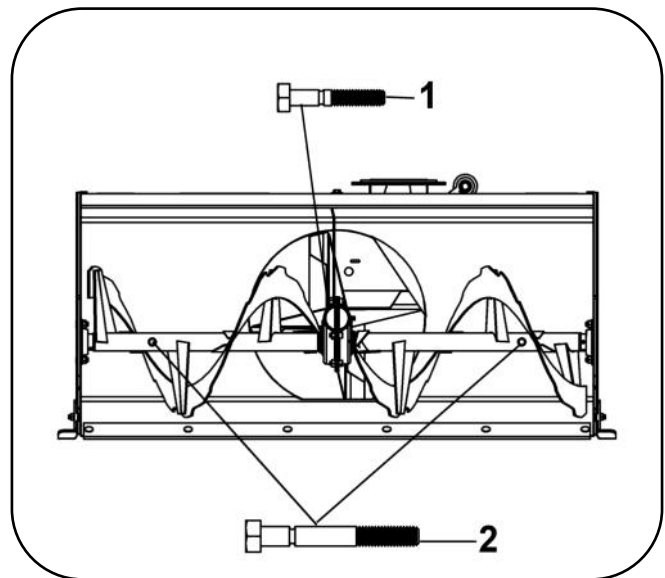

Shear bolt

MAINTENANCE



CAUTION



Never use the snowblower without the belt guard.

BELT REPLACEMENT

Use a BX-55 (#106110) as a replacement belt.

1. Remove the belt guard (**item 1**) by removing the three hex bolts 1/4" x 1/2" (**item 2**) and the three spring washers 1/4" (**item 3**); and the three flat washers 5/16" (**item 4**);
2. Remove the hair pin (**item 5**) and pin (**item 6**);
3. Raise the tensioner (**item 7**) to remove the tension on the belt (**item 8**);
4. Remove the old belt and install the new one;
5. Reapply the tension on the belt by lowering the tensioner;
6. Make sure the flat idler tensioner pulley is properly aligned on the pulley.
7. Secure the tensioner with the pin and hair pin;
8. Reinstall the belt guard and secure it with three bolts and three spring washers;
9. Make sure the electromagnetic clutch pulley does not rub on the belt guard.

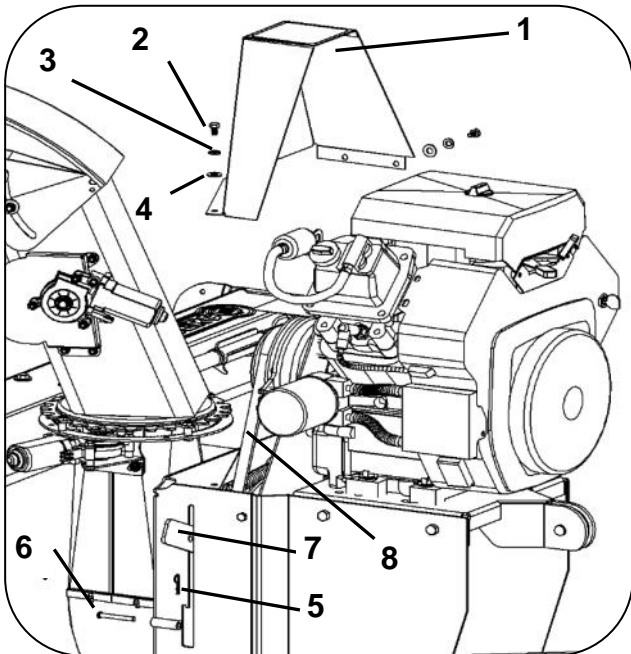

Belt replacement

BELT TENSION ADJUSTMENT

If the belt becomes too stretched, it is possible to change the position of the spring on the tensioner. Just move the carriage bolt (**item 1**), the sleeve (**item 2**), the flat washer (**item 3**) and nut (**item 4**) to position B instead of position A.

WARNING: Too much tension on the belt will considerably reduce the belt's life span. Ideally, 7 lbs (30N) of force are needed to obtain a 7/32" (5mm) deflection.

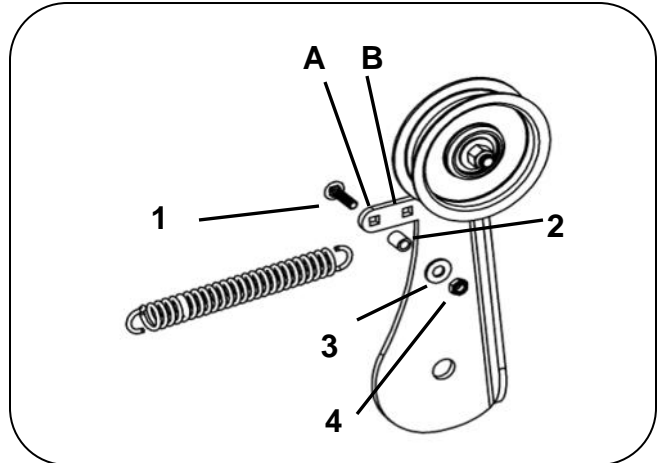

Adjusting the tension on the belt

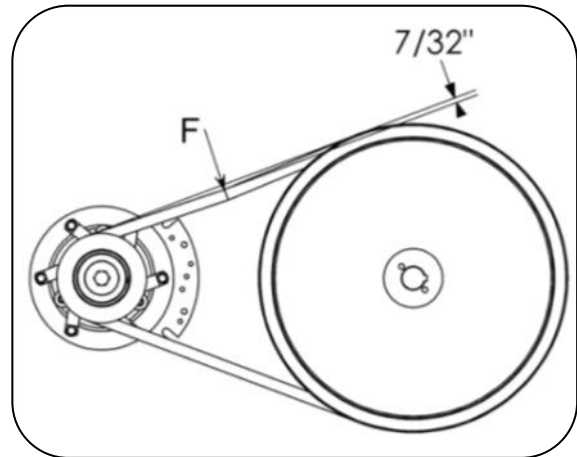

Measure the tension on the belt

MAINTENANCE

REPLACING THE AUGERS, FAN AND / OR THE GEAR BOX

To identify the part numbers, refer to the snowblower parts breakdown.

NOTE: The snowblower must be disconnected and removed from the vehicle before replacing the auger or the gear box.

1. If applicable, remove the gas tank from the support and place it on the ground (to prevent any risks of spills);
2. Remove the belt guard & belt (see belt replacement section);
3. Remove the hex bolts 7/16" x 1 1/4" (item 1) and the hex bolts 1/4" x 3/4" (item 2). Remove the hitch from the snowblower.

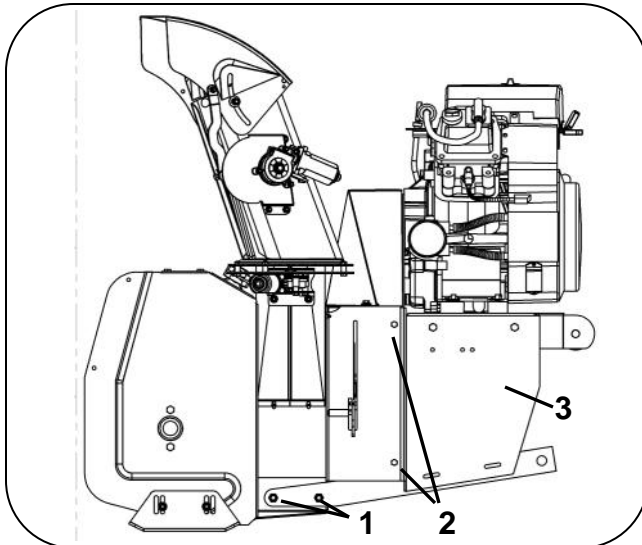

Remove the V pulley

4. Loosen the two set screws (item 1) from the V pulley (it may be necessary to heat the set screw and the center of the pulley around the shaft to soften the "Loctite")
5. Remove the V pulley with a puller.

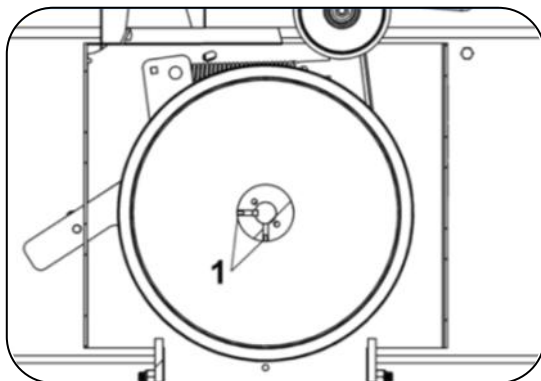

Remove the V pulley

6. Loosen the two set screws (item 1) from ball bearing behind the snowblower (it may be necessary to heat the set screw and the center of the bearing around the shaft to soften the "Loctite").

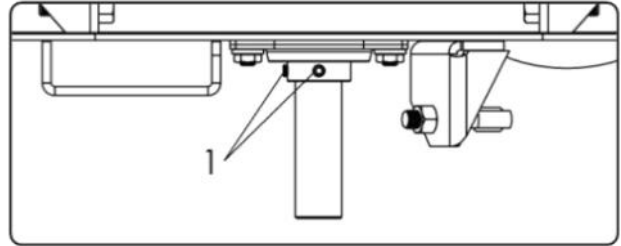

Loosen the set screws from the ball bearing

7. Remove all the bolts (item 3) and nuts supporting the gear box, its support and augers.
8. Remove the assembly (the gear box, its support, fan, the snowblower augers keeping the nylon bushings and the bearings);
9. Replace the appropriate parts making sure to reassemble the parts as shown below;
10. Reinstall the parts.

IMPORTANT: Clean the parts and apply some "Loctite" 2760 on the key of the pulley and on the set screws of the bearings and those of the pulley. Firmly tighten the set screws.

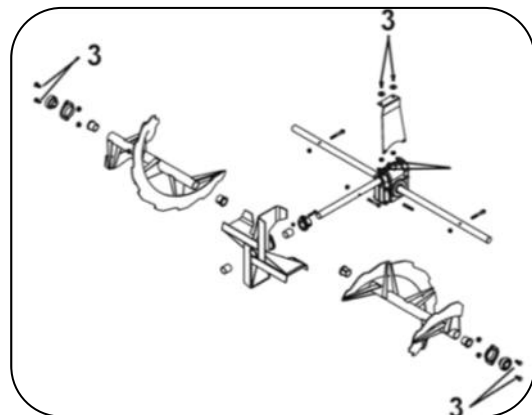

Remove the bolts

DISMOUNTING AND STORAGE

DISMOUNTING

1. Select a level surface, set the parking brake, stop the engine and remove the ignition key to prevent accidental starting.
2. Lower the accessory to the ground
3. Disconnect the electrical wiring on the front of the vehicle.
4. Unhook the winch hook and remove the winch cable from the pulley.
5. Unhook the turnbuckles from the front of the vehicle. (Tip: loosen one of the turnbuckles in order to keep the adjustment) and the hitch from the rear of the vehicle.
6. Remove the vehicle.

STORAGE

1. Clean the snowblower and subframe thoroughly.
2. Paint all the parts wear the paint has worn out.
3. List the parts that will be needed to be replaced next season.
4. Follow the instructions in the lubrication section.
5. Follow the instructions in the engine owner's manual
6. Store the snowblower and subframe in a dry area.

ATV & UV SNOWBLOWER TROUBLESHOOTING

* Please refer to parts breakdown section for parts identification.

PROBLEM	POSSIBLE CAUSES	CORRECTIVE ACTION
Snowblower vibrates or is abnormally noisy or bouncing. Snowblower bouncing up & down when ingesting snow.	Damaged pulley	Replace pulley
	Damaged bearing	Replace the bearing
	Fan or the augers are damaged	Remove and straighten or replace the parts
	Fan or auger bushings are worn	Replace with new bushings
	Augers are not positioned properly	Make sure the ends of the 2 augers are positioned 180° from one and the other when replacing shear bolts. See auger & fan shear bolt replacement section in manual.
Fan stops turning	Shear bolt is probably broken	Replace shear bolt (see maintenance section).
Auger stops turning	Shear bolt is probably broken	Replace shear bolt (see maintenance section).
Snowblower stops turning.	Belt is probably damaged or broken	Check and replace damaged belt
Belt is snapping, shredding, burning or worn in a specific place	Snowblower was engaged when clogged	Make sure the auger and the fan are not frozen or clogged before engaging
	Lack of tension on the belt	Adjust the tensioner spring or replace spring if stretched.
Belt shows premature wear	Not the original belts	Always use the original belts
	Worn belt, Belt may be worn causing a slack.	Inspect the belt. Replace if required.
	Not the original shear bolts	Always replace the shear bolts with an original bolt.
	Imperfections in the pulleys	Verify if the pulleys are damaged. Verify that the pulleys are smooth without rust spots. Sand down the pulleys or replace them.
	Interference	Make sure that the belt does not come into contact with any other part, bolts, guides etc... when engaged.
Chute rotation is difficult	Dirt or ice may be underneath chute.	Dismount chute. Clean the base of chute and the rotation ring. Lubricate & re-install.
Chute plugs easily.	Snowblower engine running too slowly.	Run engine at full R.P.M. during snow blowing operation.
	Advancing too quickly with vehicle.	Reduce vehicle's speed.. Allow snowblower to ingest snow at its own speed.
Snowblower digs into ground.	Ground is not frozen or too soft.	Adjust skid shoes lower so they may better support the snowblower. If problem persists, change skid shoes for heavy duty skid shoes (option #700243) which cover more surface and prevents snowblower from digging.
Snowblower does not rise evenly.	Pressure of the subframe tires is uneven from one side to another.	Tire pressure must be even on both sides. 50 p.s.i.

TROUBLESHOOTING

* Please refer to parts breakdown section for parts identification.

PROBLEM	POSSIBLE CAUSES	CORRECTIVE ACTION
The engine does not start	The emergency button is pushed down.	The emergency button must be pulled up to start the engine of the snowblower.
	The electromagnetic clutch is activated	Deactivate the electromagnetic clutch.
	Other reasons.	See owner's manual
Electric chute motor does not work.	Overheating of the motor.	These motors are equipped with an internal protector. Wait 10 minutes before using.
	Frozen motor or chute.	Slap the chute or wiggle from side to side.
	Defective control box or broken wire harness.	Replace control box or wire harness.
	Loose connectors or oxidation on connectors or motor.	Retighten or clean connectors. Or replace connector part # 106201.
Electric clutch slips	Insufficient electrical current.	Recharge vehicle's battery.
	Electrical current is cut off.	Replace damaged wiring.
	Clutch basket is contaminated.	Clean plates with brake cleaner.
Electric clutch is noisy or vibrates abnormally.	Mounting bolts are loose.	Tighten or replace bolts.
	Certain clutch components may be damaged.	Repair or replace damaged components.
Engine shuts off when the electric clutch is engaged.	Certain oil sensors may be sensitive to the electromagnetic field created by the clutch. Therefore when the clutch is engaged, it can activate the automatic engine shut off on the ignition coil.	Disconnect the oil sensor.

In the case of where the wires become disconnected from the relay, refer to the drawing below to reconnect them in their proper place.

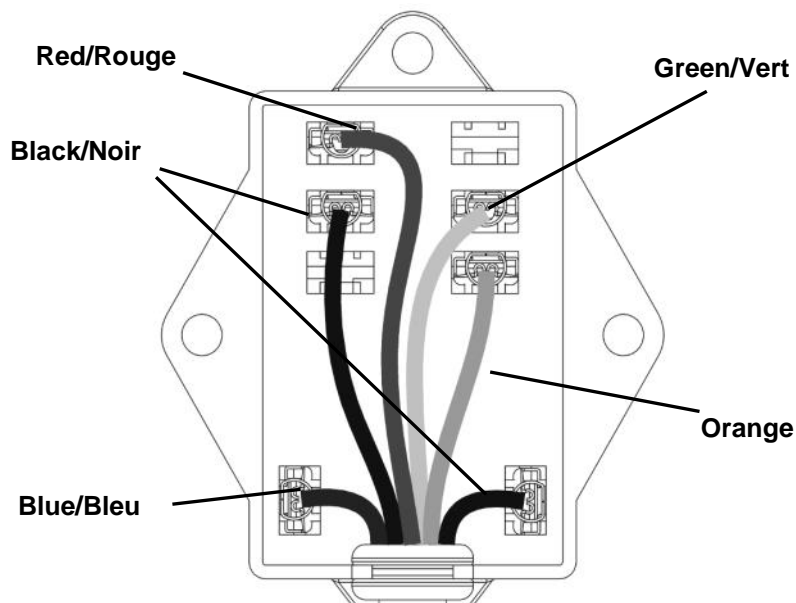

PARTS BREAKDOWN

48" SNOWBLOWER # 700580-1-SM

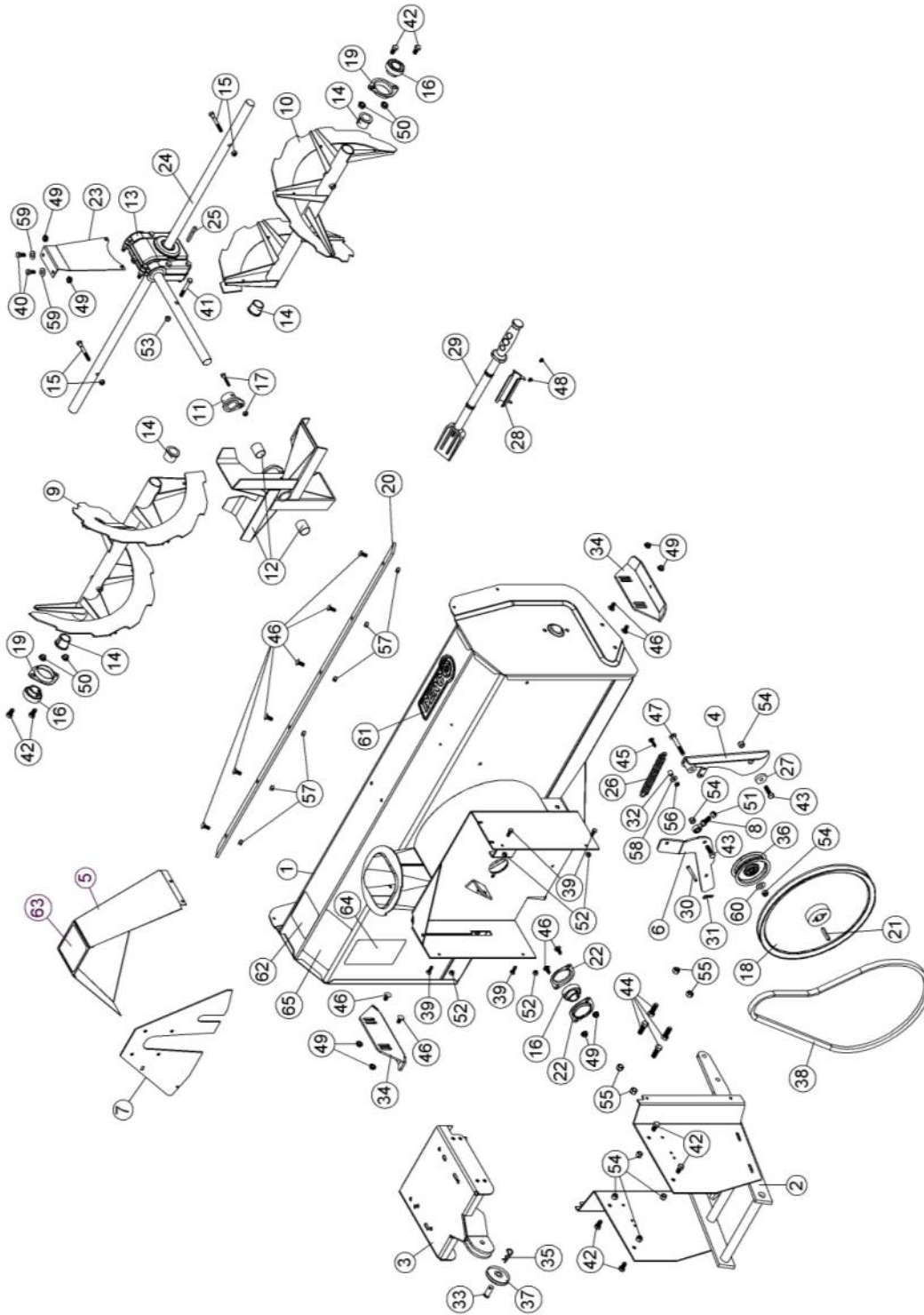

PARTS LIST
48" SNOWBLOWER # 700580-1-SM

Ref. Réf.	English description	Description française	Qty. Qté.	Part # Pièce #
1	Frame 48" with safety decals & cutting edge	Chassis 48" avec décalques de séc. & racloir	1	106609
2	Hitch	Attache	1	106606
3	Engine support	Support moteur	1	106607
4	Bender	Tendeur	1	106608
5	Belt guard with safety decal	Garde-courroie avec décalque de sécurité	1	106611
6	Lever	Levier	1	106612
7	Guard	Garde	1	106164
8	Rod end assembly	Embout assemblé	1	106184
9	Auger 48" left	Vis 48" gauche	1	104765
10	Auger 48" right	Vis 48" droite	1	104766
11	Shear plate	Plaque de cisaillement	1	103933
12	Fan with bushing	Éventail avec coussinet	1	105660
13	Gear box left rotation	Boîte d'engrenage rotation gauche	1	104718
14	Rotation bushing	Coussinet de rotation	4	103946
15	Shear bolt / N.I.L.N. (auger) pkg-10	Boulon de séc. / É.G.N. (vis) pqt-10	2	104000
16	Bearing with set screw	Roulement à billes avec vis à pression	3	102755
17	Shear bolt / N.I.L.N. (fan) pkg-10	Boulon de séc./ É.G.N. (éven.) pqt-10	1	103999
18	V pulley with set screw	Poulie en V avec vis pression	1	105423
19	Flangette	Flangette	2	102680
20	Cutting edge 48"	Racloir 48"	1	103187
21	Key 1/4" x 1/4" x 1 3/4"	Clé 1/4" x 1/4" x 1 3/4"	1	102327
22	Flangette	Flangette	2	102213
23	Gear box support	Support de boîte d'engrenage	1	104746
24	Shaft 48"	Arbre 48"	1	104721
25	Key 1/4" x 1/4" x 2"	Clé 1/4" x 1/4" x 2"	1	102922
26	Spring	Ressort	1	102592
27	Flange washer	Rondelle à bride	1	102081
28	Chute shovel support	Support de pelle à goulotte	1	105701
29	Chute shovel	Pelle à goulotte	1	105700
30	Pin	Goupille	1	105365
31	Hair pin 2mm	Goupille à ressort 2mm	1	102430
32	Spacer	Espaceur	1	103361
33	Pin	Goupille	1	103070

O/L = Obtain Locally

PARTS LIST

48" SNOWBLOWER #700580-1-SM

Ref. Réf.	English description	Description française	Qty. Qté.	Part # Pièce #
34	Skid shoe	Patin	2	103188
35	Hair pin 3mm	Goupille à ressort 3mm	1	102617
36	Flat pulley	Poulie plate	1	102765
37	Pulley	Poulie	1	106138
38	V-belt, BX-55	Courroie en V, BX-55	1	106110
39	Hex. bolt 1/4" n.c. x 3/4" GR5	Boulon hex. 1/4" n.c. x 3/4" GR5	4	O/L
40	Hex. bolt 5/16" n.c. x 3/4" GR5	Boulon hex. 5/16" n.c. x 3/4" GR5	2	O/L
41	Hex. bolt 5/16" n.c. x 2 1/4" GR8	Boulon hex. 5/16" n.c. x 2 1/4" GR8	1	O/L
42	Hex. bolt 3/8" n.c. x 3/4" GR5	Boulon hex. 3/8" n.c. x 3/4" GR5	8	O/L
43	Hex. bolt 3/8" n.c. x 1 1/4" GR5	Boulon hex. 3/8" n.c. x 1 1/4" GR5	2	O/L
44	Hex. bolt 7/16" n.c. x 1 1/4" GR5	Boulon hex. 7/16" n.c. x 1 1/4" GR5	4	O/L
45	Carriage bolt 1/4" n.c. x 1 " GR5	Boulon à carrosserie 1/4" n.c. x 1 " GR5	1	O/L
46	Carriage bolt 5/16" n.c. x 3/4 " GR5	Boulon à carrosserie 5/16" n.c. x 3/4 " GR5	12	O/L
47	Carriage bolt 3/8" n.c. x 2 3/4" GR5	Boulon à carrosserie 3/8" n.c. x 2 3/4" GR5	1	O/L
48	Socket Head Cap Screw M5 x 0.80 x 10	Vis six PC tête ronde M5 x 0.80 x 10	2	O/L
49	Flange nut 5/16" n.c.	Écrou à bride 5/16" n.c.	8	O/L
50	Flange nut 3/8" n.c.	Écrou à bride 3/8" n.c.	4	O/L
51	Nylon insert lock nut 3/8" n.f.	Écrou garniture de nylon 3/8" n.f.	1	O/L
52	Nylon Insert lock Nut 1/4" n.c.	Écrou à garniture de nylon 1/4" n.c.	4	O/L
53	Nylon Insert lock Nut 5/16" n.c. GR5	Écrou à garniture de nylon 5/16" n.c. GR5	1	O/L
54	Nylon Insert lock Nut 3/8" n.c.	Écrou à garniture de nylon 3/8" n.c.	7	O/L
55	Nylon Insert lock Nut 7/16" n.c.	Écrou à garniture de nylon 7/16" n.c.	4	O/L
56	Nylon insert lock nut 1/4" n.c. (thin)	Écrou à garniture de nylon 1/4" n.c. (mince)	1	O/L
57	Stover lock nut 5/16" n.c.	Écrou de blocage 5/16" n.c.	6	O/L
58	Flat washer 5/16" hole	Rondelle plate 5/16" trou	1	O/L
59	Flat washer 3/8" hole	Rondelle plate 3/8" trou	2	O/L
60	Flat washer 7/16" hole	Rondelle plate 7/16" trou	1	O/L
61	Berco decal	Décalque Berco	1	102471
62	Decal danger auger	Decalque danger vis	1	105126
63	Decal danger belts	Decalque danger courroies	1	105128
64	Decal read instructions	Decalque lire instructions	1	105130
65	Decal warning safety	Decalque avertissement sécurité	1	105131

O/L = Obtain Locally

PARTS BREAKDOWN

54" SNOWBLOWER # 700582-1-SM

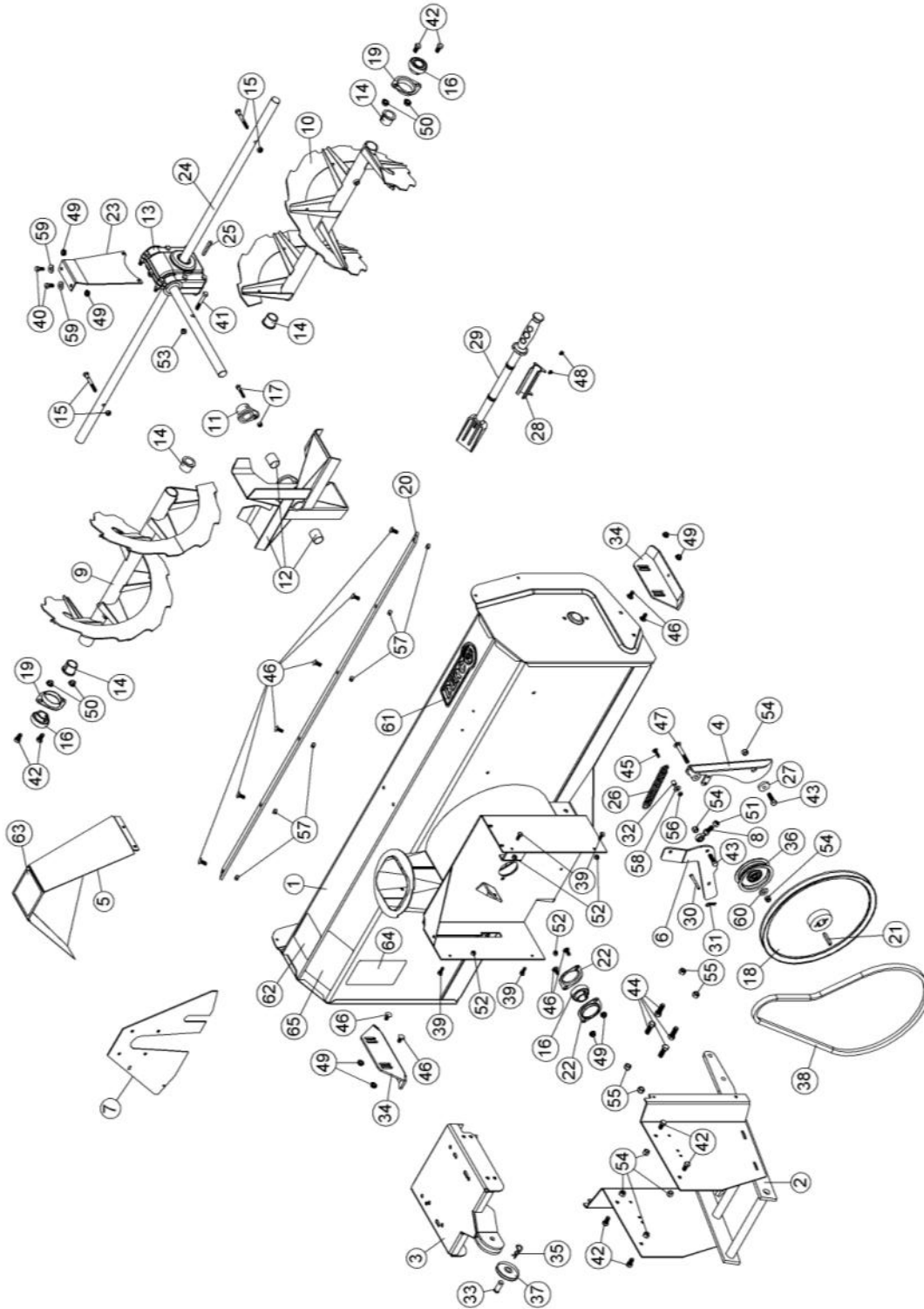

PARTS LIST

54" SNOWBLOWER #700582-1-SM

Ref. Réf.	English description	Description française	Qty. Qté.	Part # Pièce #
1	Frame 54" with safety decals & cutting edge	Chassis 54" avec décalques de séc. & racloir	1	106615
2	Hitch	Attache	1	106606
3	Engine support	Support moteur	1	106607
4	Bender	Tendeur	1	106608
5	Belt guard with safety decal	Garde-courroie avec décalque de sécurité	1	106611
6	Lever	Levier	1	106612
7	Guard	Garde	1	106164
8	Rod end assembly	Embout assemblé	1	106184
9	Auger 54" left	Vis 54" gauche	1	104747
10	Auger 54" right	Vis 54" droite	1	104748
11	Shear plate	Plaque de cisaillement	1	103933
12	Fan with bushing	Éventail avec coussinet	1	105660
13	Gear box left rotation	Boîte d'engrenage rotation gauche	1	104718
14	Rotation bushing	Coussinet de rotation	4	103946
15	Shear bolt / N.I.L.N. (auger) pkg-10	Boulon de séc. / É.G.N. (vis) pqt-10	2	104000
16	Bearing with set screw	Roulement à billes avec vis à pression	3	102755
17	Shear bolt / N.I.L.N. (fan) pkg-10	Boulon de séc./ É.G.N. (éven.) pqt-10	1	103999
18	V pulley with set screw	Poulie en V avec vis pression	1	105423
19	Flangette	Flangette	2	102680
20	Cutting edge 54"	Racloir 54"	1	104427
21	Key 1/4" x 1/4" x 1 3/4"	Clé 1/4" x 1/4" x 1 3/4"	1	102327
22	Flangette	Flangette	2	102213
23	Gear box support	Support de boîte d'engrenage	1	104746
24	Shaft 54"	Arbre 54"	1	104722
25	Key 1/4" x 1/4" x 2"	Clé 1/4" x 1/4" x 2"	1	102922
26	Spring	Ressort	1	102592
27	Flange washer	Rondelle à bride	1	102081
28	Chute shovel support	Support de pelle à goulotte	1	105701
29	Chute shovel	Pelle à goulotte	1	105700
30	Pin	Goupille	1	105365
31	Hair pin 2mm	Goupille à ressort 2mm	1	102430
32	Spacer	Espaceur	1	103361
33	Pin	Goupille	1	103070

O/L = Obtain Locally

PARTS LIST

54" SNOWBLOWER #700582-1-SM

Ref. Réf.	English description	Description française	Qty. Qté.	Part # Pièce #
34	Skid shoe	Patin	2	103188
35	Hair pin 3mm	Goupille à ressort 3mm	1	102617
36	Flat pulley	Poulie plate	1	102765
37	Pulley	Poulie	1	106138
38	V-belt, BX-55	Courroie en V, BX-55	1	106110
39	Hex. bolt 1/4" n.c. x 3/4" GR5	Boulon hex. 1/4" n.c. x 3/4" GR5	4	O/L
40	Hex. bolt 5/16" n.c. x 3/4" GR5	Boulon hex. 5/16" n.c. x 3/4" GR5	2	O/L
41	Hex. bolt 5/16" n.c. x 2 1/4" GR8	Boulon hex. 5/16" n.c. x 2 1/4" GR8	1	O/L
42	Hex. bolt 3/8" n.c. x 3/4" GR5	Boulon hex. 3/8" n.c. x 3/4" GR5	8	O/L
43	Hex. bolt 3/8" n.c. x 1 1/4" GR5	Boulon hex. 3/8" n.c. x 1 1/4" GR5	2	O/L
44	Hex. bolt 7/16" n.c. x 1 1/4" GR5	Boulon hex. 7/16" n.c. x 1 1/4" GR5	4	O/L
45	Carriage bolt 1/4" n.c. x 1 " GR5	Boulon à carrosserie 1/4" n.c. x 1 " GR5	1	O/L
46	Carriage bolt 5/16" n.c. x 3/4 " GR5	Boulon à carrosserie 5/16" n.c. x 3/4 " GR5	12	O/L
47	Carriage bolt 3/8" n.c. x 2 3/4" GR5	Boulon à carrosserie 3/8" n.c. x 2 3/4" GR5	1	O/L
48	Socket Head Cap Screw M5 x 0.80 x 10	Vis six PC tête ronde M5 x 0.80 x 10	2	O/L
49	Flange nut 5/16" n.c.	Écrou à bride 5/16" n.c.	8	O/L
50	Flange nut 3/8" n.c.	Écrou à bride 3/8" n.c.	4	O/L
51	Nylon insert lock nut 3/8" n.f.	Écrou garniture de nylon 3/8" n.f.	1	O/L
52	Nylon Insert lock Nut 1/4" n.c.	Écrou à garniture de nylon 1/4" n.c.	4	O/L
53	Nylon Insert lock Nut 5/16" n.c. GR5	Écrou à garniture de nylon 5/16" n.c. GR5	1	O/L
54	Nylon Insert lock Nut 3/8" n.c.	Écrou à garniture de nylon 3/8" n.c.	7	O/L
55	Nylon Insert lock Nut 7/16" n.c.	Écrou à garniture de nylon 7/16" n.c.	4	O/L
56	Nylon insert lock nut 1/4" n.c. (thin)	Écrou à garniture de nylon 1/4" n.c. (mince)	1	O/L
57	Stover lock nut 5/16" n.c.	Écrou de blocage 5/16" n.c.	6	O/L
58	Flat washer 5/16" hole	Rondelle plate 5/16" trou	1	O/L
59	Flat washer 3/8" hole	Rondelle plate 3/8" trou	2	O/L
60	Flat washer 7/16" hole	Rondelle plate 7/16" trou	1	O/L
61	Berco decal	Décalque Berco	1	102471
62	Decal danger auger	Decalque danger vis	1	105126
63	Decal danger belts	Decalque danger courroies	1	105128
64	Decal read instructions	Decalque lire instructions	1	105130
65	Decal warning safety	Decalque avertissement sécurité	1	105131

O/L = Obtain Locally

PARTS BREAKDOWN CHUTE

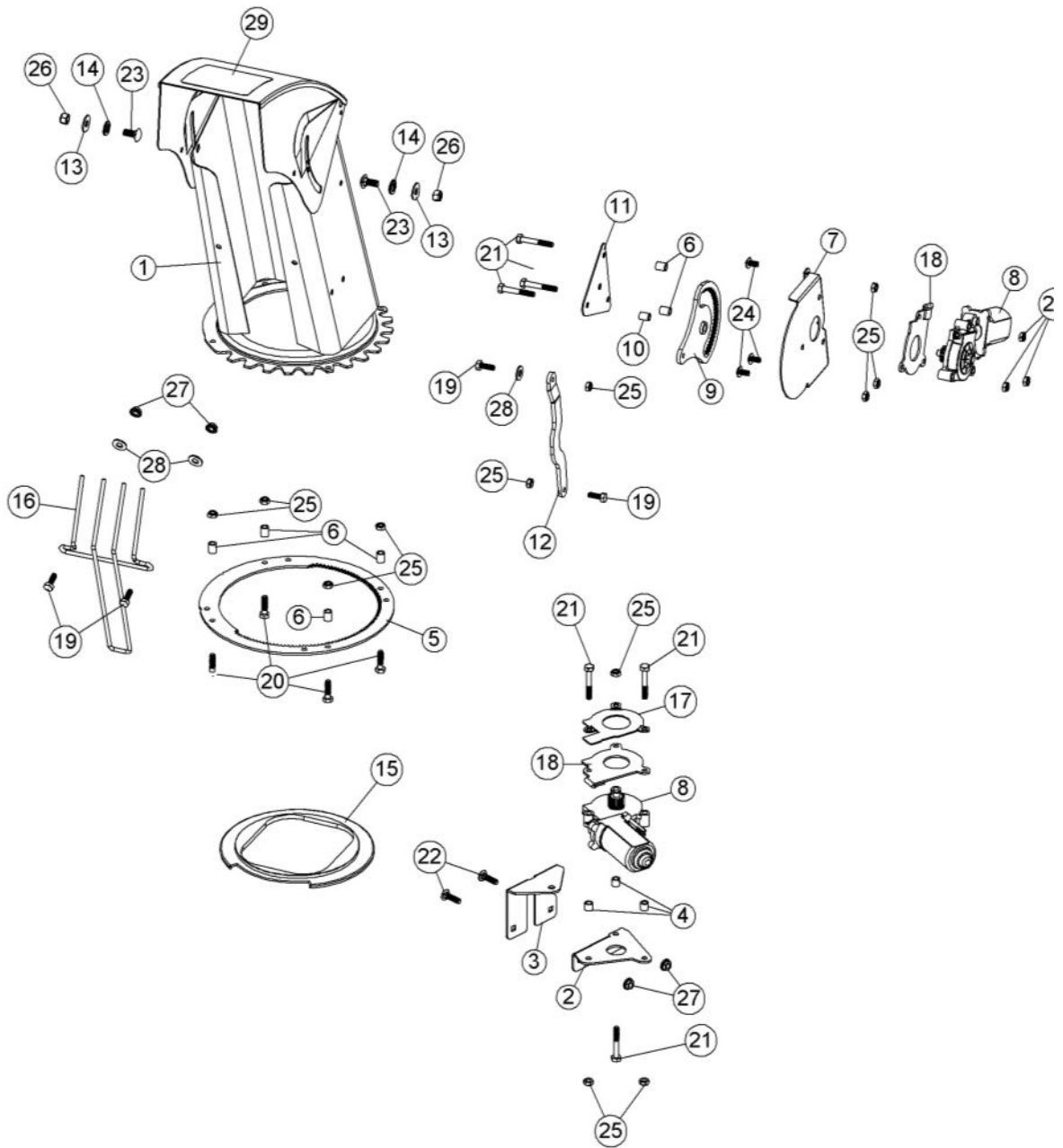

PARTS LIST CHUTE

Ref. Réf.	English description	Description française	Qty. Qté.	Part # Pièce #
1	Chute with decal	Goulotte avec décalque	1	106613
2	Bracket	Support	1	103971
3	Reinforcement plate	Plaque de renforcement	1	103972
4	Spacer	Espaceur	3	103368
5	Rotation ring	Anneau de rotation	1	106327
6	Spacer	Espaceur	6	103361
7	Bracket	Support	1	103375
8	Electric motor	Moteur électrique	2	106147
9	Lever	Levier	1	103365
10	Oil lite bushing	Coussinet imprégné d'huile	1	103362
11	Plate	Plaque	1	103363
12	Arm	Bras	1	103364
13	Nylon flat washer 11/32"	Rondelle plate de nylon 11/32"	2	102009
14	Nylon flat washer 7/16"	Rondelle plate de nylon 7/16"	2	102011
15	Rotation ring	Anneau de rotation	1	103943
16	Hand guard	Fourche protectrice	1	102012
17	Protective plate	Plaque protectrice	1	105404
18	Gasket	Joint d'étanchéité	2	106570
19	Hex. bolt 1/4" n.c. x 3/4" GR5	Boulon hex. 1/4" n.c. x 3/4" GR5	4	O/L
20	Hex. bolt 1/4" n.c. x 1" GR5	Boulon hex. 1/4" n.c. x 1" GR5	4	O/L
21	Hex. bolt 1/4" n.c. x 1 3/4" GR5	Boulon hex. 1/4" n.c. x 1 3/4" GR5	6	O/L
22	Carriage bolt 1/4" n.c. x 1 " GR5	Boulon à carrosserie 1/4" n.c. x 1 " GR5	2	O/L
23	Carriage bolt 5/16" n.c. x 3/4 " GR5	Boulon à carrosserie 5/16" n.c. x 3/4 " GR5	2	O/L
24	Machine screw T.H. 1/4" n.c. x 1/2"	Vis mécanique T.H. 1/4" n.c. x 1/2"	3	O/L
25	Nylon insert lock nut 1/4" n.c. (thin)	Écrou à garniture de nylon 1/4" n.c. (mince)	15	O/L
26	Nylon Insert lock Nut 5/16" n.c. GR5	Écrou à garniture de nylon 5/16" n.c. GR5	2	O/L
27	Flange nut 1/4" n.c.	Écrou à bride 1/4" n.c.	4	O/L
28	Flat washer 5/16" hole	Rondelle plate 5/16" trou	3	O/L
29	Danger decal chute	Décalque danger goulotte	1	105127

O/L = Obtain Locally

PARTS BREAKDOWN SUBFRAME

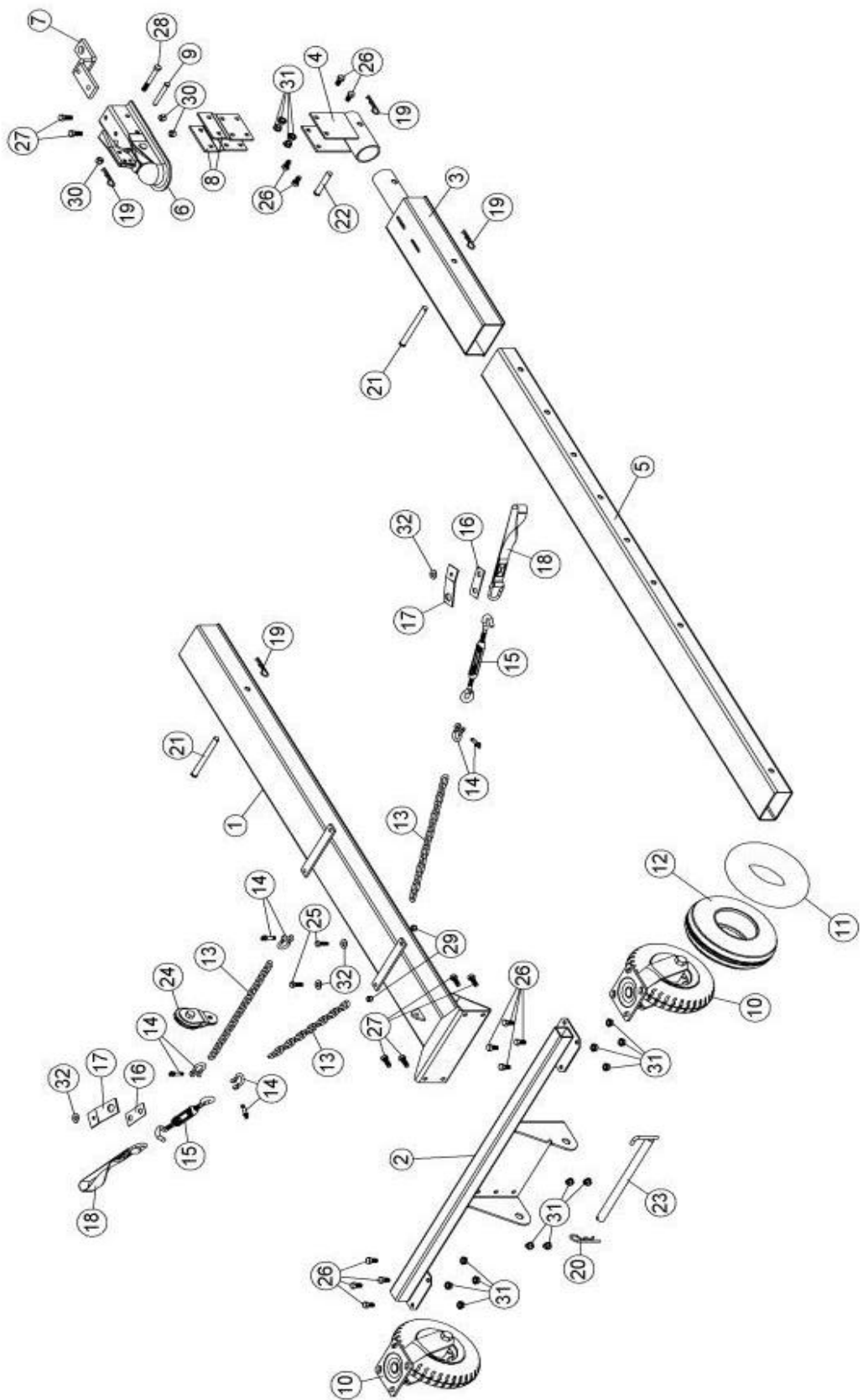

PARTS LIST SUBFRAME

Ref. Réf.	English description	Description française	Qty. Qté.	Part # Pièce #
1	Subframe	Sous-châssis	1	104957
2	Wheel support	Support de roue	1	104770
3	Rear bracket	Fixation arrière	1	104956
4	Hitch support	Support d'attache	1	104958
5	Adjustment tube	Tube d'ajustement	1	104959
6	Hitch	Attache	1	104639
7	Hitch ball support	Support de boule d'attelage	1	104640
8	Hitch support plate	Plaque de support d'attache	2	104641
9	Pin	Goupille	1	104642
10	Caster wheel assembly	Roue pivotante assemblée	2	105679
11	Inner tube 250-4	Chambre à air 250-4	1	102675
12	Tire 280/250-4	Pneu 280/250-4	1	102674
13	Chain	Chaîne	3	104633
14	Shackle Ptd Z	Clevis Pqé Z	4	102343
15	Turnbuckle	Tendeur	2	104634
16	Bracket	Fixation	2	104632
17	Bracket	Fixation	2	105194
18	Lift strap	Sangle de relevage	2	103613
19	Hair pin 3mm	Goupille à ressort 3mm	4	102617
20	Hair pin 4mm	Goupille à ressort 4mm	1	102054
21	Pin	Goupille	2	104961
22	Pin	Goupille	1	104999
23	Pin	Goupille	1	104759
24	Pulley assembly	Poulie assemblée	1	106140
25	Hex. bolt 5/16" n.c. x 1" GR5	Boulon hex. 5/16" n.c. x 1" GR5	2	O/L
26	Hex. bolt 3/8" n.c. x 3/4" GR5	Boulon hex. 3/8" n.c. x 3/4" GR5	12	O/L
27	Hex. bolt 3/8" n.c. x 1" GR5	Boulon hex. 3/8" n.c. x 1" GR5	6	O/L
28	Hex. bolt 3/8" n.c. x 3" GR5	Boulon hex. 3/8" n.c. x 3" GR5	1	O/L
29	Nylon Insert lock Nut 5/16" n.c.	Écrou à garniture de nylon 5/16" n.c.	2	O/L
30	Nylon Insert lock Nut 3/8" n.c.	Écrou à garniture de nylon 3/8" n.c.	3	O/L
31	Flange nut 3/8" n.c.	Écrou à bride 3/8" n.c.	16	O/L
32	Flat washer 3/8" hole	Rondelle plate 3/8" trou	4	O/L

O/L = Obtain Locally

PARTS BREAKDOWN SNOWBLOWER WITH 14HP KOHLER ENGINE

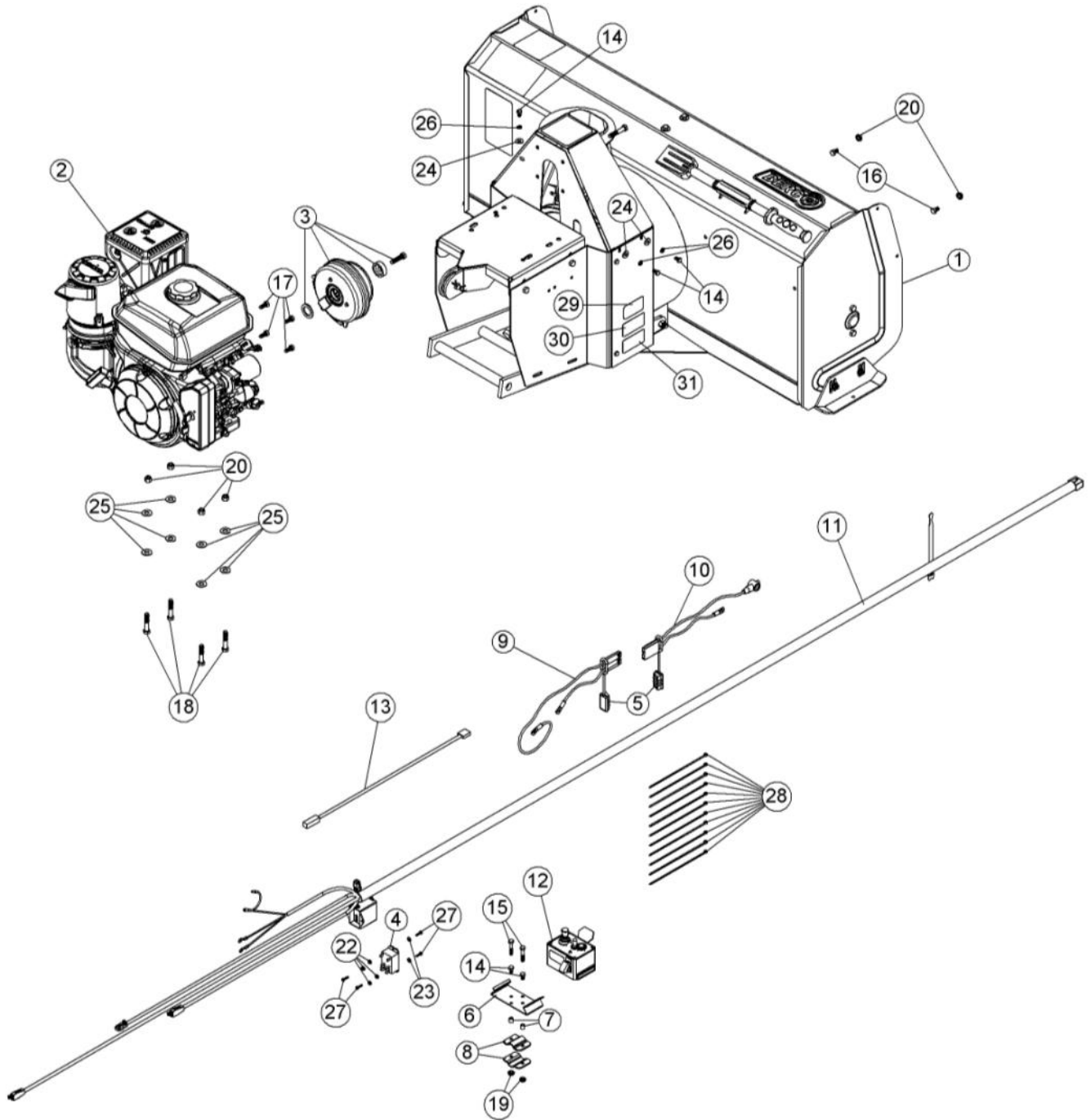

PARTS LIST

SNOWBLOWER WITH 14HP KOHLER ENGINE

Ref. Réf.	English description	Description française	Qty. Qté.	Part # Pièce #
1	Snowblower	Souffleuse à neige	1	700580 (582)-1-SM
2	Kohler Engine 14 hp	Moteur Kohler 14 CV	1	106014
3	Electric clutch assembly (Hole 1")	Embrayage électrique assemblé (Alésage 1")	1	106178
4	Relay	Relais	1	106123
5	Cap	Capuchon	2	105407
6	Box support	Support de la boîte	1	104756
7	Spacer	Espaceur	2	103368
8	Support bracket	Fixation du support	2	103068
9	Wire assembly	Fil assemblé	1	104017
10	Wire assembly	Fil assemblé	1	104018
11	Wire Assembly	Fil assemblé	1	106558
12	Control box assembly	Boîte de contrôle assemblé	1	106564
13	Wire Assembly	Fil Assemblé	1	106548
14	Hex. bolt 1/4" n.c. x 1/2" GR5	Boulon hex. 1/4" n.c. x 1/2" GR5	5	O/L
15	Hex. bolt 1/4" n.c. x 1 1/2" GR5	Boulon hex. 1/4" n.c. x 1 1/2" GR5	2	O/L
16	Hex. bolt 5/16" n.c. x 1/2" GR5	Boulon hex. 5/16" n.c. x 1/2" GR5	2	O/L
17	Hex. bolt 5/16" n.f. x 3/4" GR5	Boulon hex. 5/16" n.f. x 3/4" GR5	4	O/L
18	Hex. bolt 3/8" n.c. x 2" GR5	Boulon hex. 3/8" n.c. x 2" GR5	4	O/L
19	Flange nut 1/4" n.c.	Écrou à bride 1/4" n.c.	2	O/L
20	Flange nut 5/16" n.c.	Écrou à bride 5/16" n.c.	2	O/L
20	Nylon Insert lock Nut 3/8" n.c.	Écrou à garniture de nylon 3/8" n.c.	5	O/L
22	Nylon insert locknut #8 x 32 (thin) GR2	Écrou à garni. de nylon #8 x 32 (mince) GR2	4	O/L
23	Flat washer #10 hole	Rondelle plate #10 trou	2	O/L
24	Flat washer 5/16" hole	Rondelle plate 5/16" trou	3	O/L
25	Flat washer 7/16" hole	Rondelle plate 7/16" trou	8	O/L
26	Lock washer 1/4"	Rondelle de blocage 1/4"	3	O/L
27	Machine screw Pan head no.8 x 32 x 5/8"	Vis mécanique à tête Pan no.8 x 32 x 5/8"	4	O/L
28	Tie wrap 8"	Attache de nylon 8"	11	O/L
29	Made in Canada decal	Décalque Fabriqué au Canada	1	REF
30	Serial number	Numéro de série	1	REF
31	Specifications decal	Décalque spécifications	1	REF

O/L = Obtain Locally

PARTS BREAKDOWN SNOWBLOWER WITH 20HP HONDA ENGINE

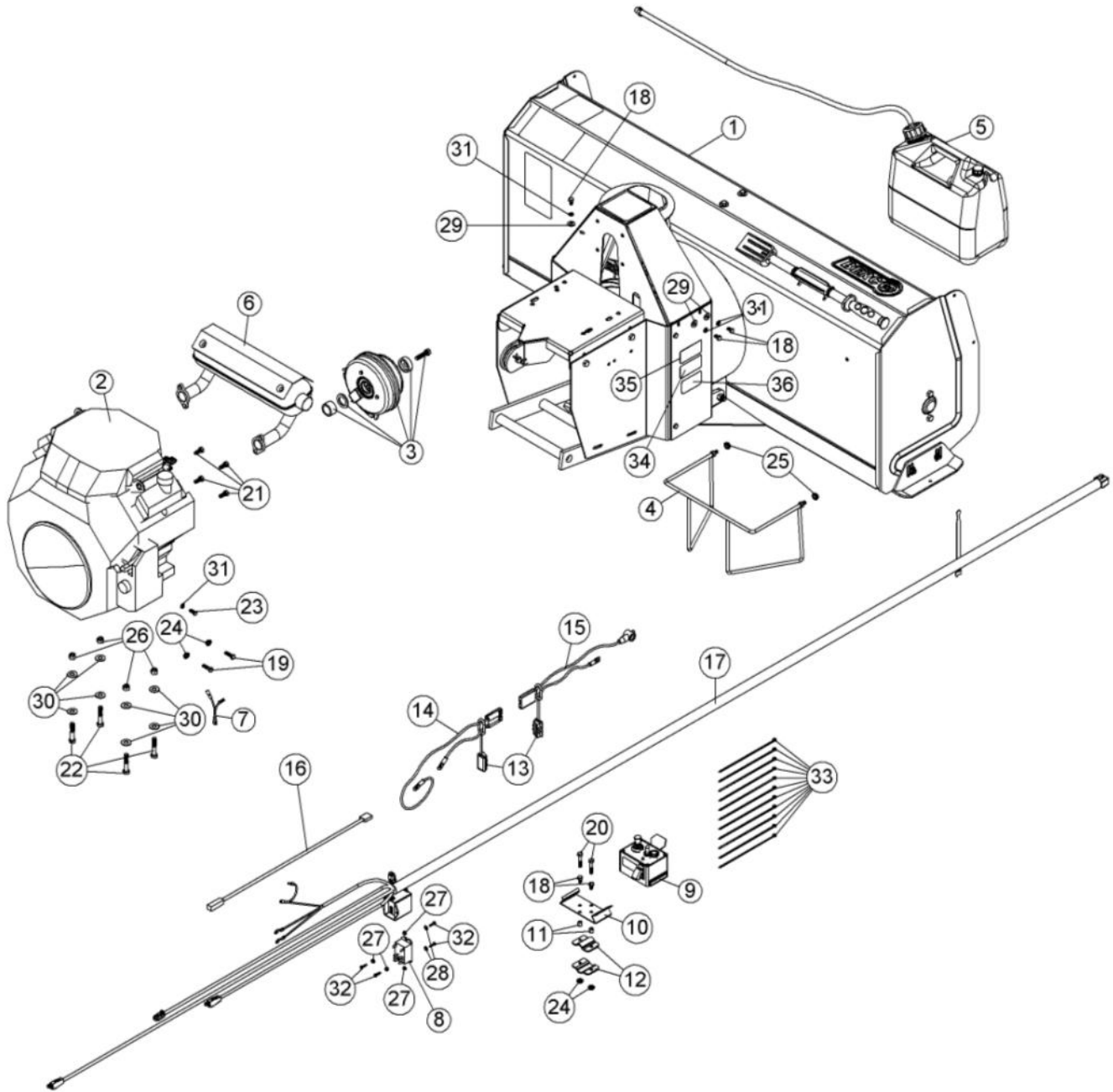

PARTS LIST

SNOWBLOWER WITH 20HP HONDA ENGINE

Ref. Réf.	English description	Description française	Qty. Qté.	Part # Pièce #
1	Snowblower	Souffleuse à neige	1	700580 (582)-1-SM
2	Honda engine 20 Hp with key	Moteur Honda 20 CV avec clé	1	105538
3	Electric clutch assembly (Hole 1")	Embrayage électrique assemblé (Alésage 1")	1	106178
4	Tank support	Support de réservoir	1	104792
5	Gasoline tank assembly	Réservoir d'essence assemblé	1	104005
6	Honda muffler	Silencieux Honda	1	105448
7	Stop emergency wire	Fil d'arrêt d'urgence	1	105597
8	Relay	Relais	1	106123
9	Control box assembly	Boîte de contrôle assemblé	1	106564
10	Box support	Support de la boîte	1	104756
11	Spacer	Espaceur	2	103368
12	Support bracket	Fixation du support	2	103068
13	Cap	Capuchon	2	105407
14	Wire assembly	Fil assemblé	1	104017
15	Wire assembly	Fil assemblé	1	104018
16	Wire Assembly	Fil Assemblé	1	106548
17	Wire Assembly	Fil assemblé	1	106558
18	Hex. bolt 1/4" n.c. x 1/2" GR5	Boulon hex. 1/4" n.c. x 1/2" GR5	5	O/L
19	Hex. bolt 1/4" n.c. x 1" GR5	Boulon hex. 1/4" n.c. x 1" GR5	2	O/L
20	Hex. bolt 1/4" n.c. x 1 1/2" GR5	Boulon hex. 1/4" n.c. x 1 1/2" GR5	2	O/L
21	Hex. bolt 5/16" n.f. x 3/4" GR5	Boulon hex. 5/16" n.f. x 3/4" GR5	4	O/L
22	Hex. bolt 3/8" n.c. x 2" GR5	Boulon hex. 3/8" n.c. x 2" GR5	4	O/L
23	Hex. bolt M6 x 1.00 x 16 GR8.8	Boulon hex. M6 x 1.00 x 16 GR8.8	1	O/L
24	Flange nut 1/4" n.c.	Écrou à bride 1/4" n.c.	4	O/L
25	Flange nut 5/16" n.c.	Écrou à bride 5/16" n.c.	2	O/L
26	Nylon Insert lock Nut 3/8" n.c.	Écrou à garniture de nylon 3/8" n.c.	4	O/L
27	Nylon insert locknut #8 x 32 (thin) GR2	Écrou à garni. de nylon #8 x 32 (mince) GR2	4	O/L
28	Flat washer #10 hole	Rondelle plate #10 trou	2	O/L
29	Flat washer 5/16" hole	Rondelle plate 5/16" trou	3	O/L
30	Flat washer 7/16" hole	Rondelle plate 7/16" trou	8	O/L

O/L = Obtain Locally

PARTS LIST
SNOWBLOWER WITH 20HP HONDA ENGINE

Ref. Réf.	English description	Description française	Qty. Qté.	Part # Pièce #
31	Lock washer 1/4"	Rondelle de blocage 1/4"	4	O/L
32	Machine screw Pan head no.8 x 32 x 5/8"	Vis mécanique à tête Pan no.8 x 32 x 5/8"	4	O/L
33	Tie wrap 8"	Attache de nylon 8"	11	O/L
34	Specifications decal	Décalque spécifications	1	REF
35	Serial number	Numéro de série	1	REF
36	Made in Canada decal	Décalque Fabriqué au Canada	1	REF

O/L = Obtain Locally

PARTS BREAKDOWN SNOWBLOWER WITH 23HP KOHLER ENGINE

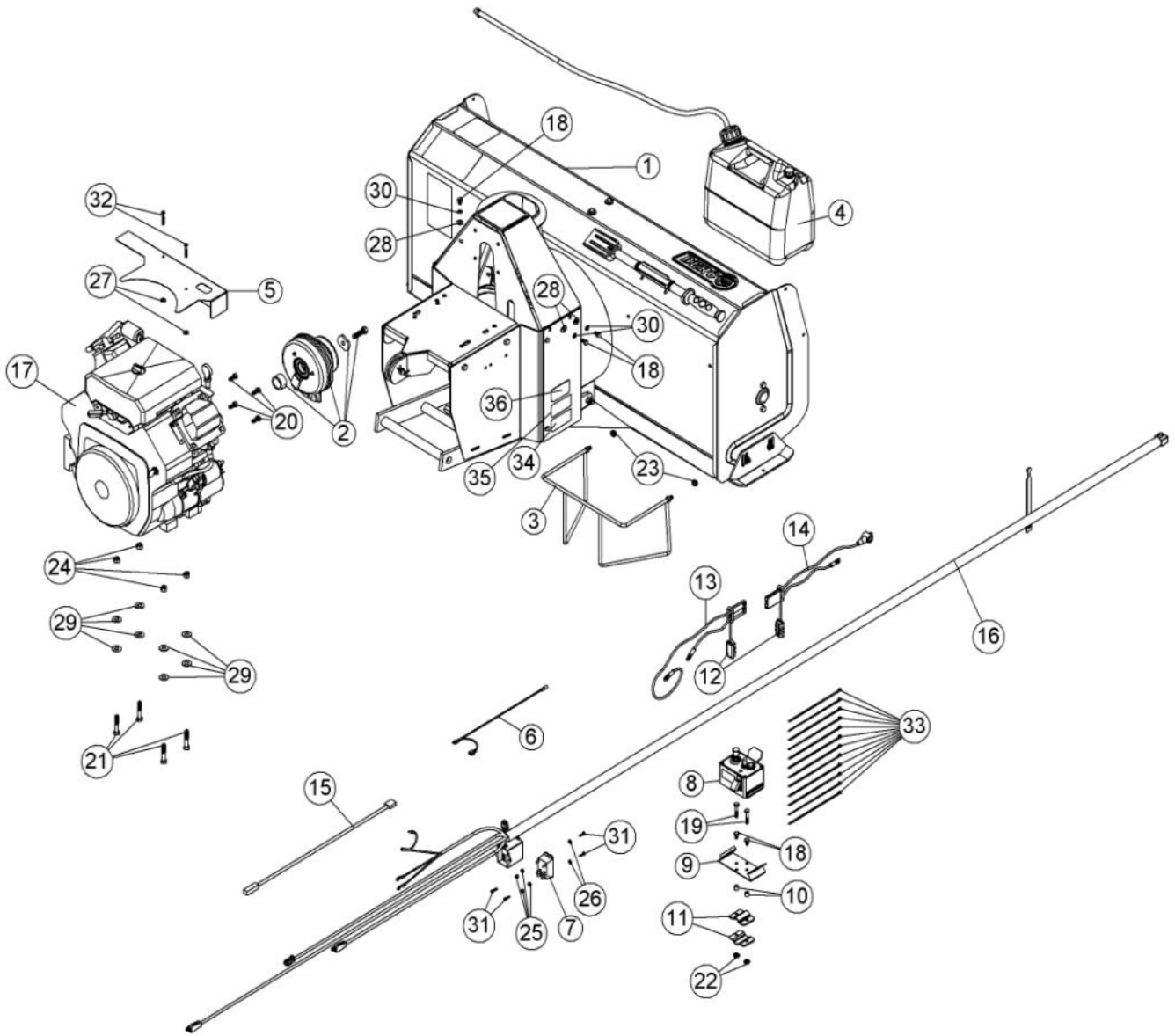

PARTS LIST

SNOWBLOWER WITH 23HP KOHLER ENGINE

Ref. Réf.	English description	Description française	Qty. Qté.	Part # Pièce #
1	Snowblower	Souffleuse à neige	1	700580 (582)-1-SM
2	Electric Clutch Assembly (Hole 1 1/8")	Embrayage électrique ass. (Alésage 1 1/8")	1	106179
3	Tank support	Support de réservoir	1	104792
4	Gasoline tank assembly	Réservoir d'essence assemblé	1	104005
5	Heat shield	Pare-chaaleur	1	104621
6	Wire assembly	Fil assemblé	1	105218
7	Relay	Relais	1	106123
8	Control box assembly	Boîte de contrôle assemblé	1	106564
9	Box support	Support de la boîte	1	104756
10	Spacer	Espaceur	2	103368
11	Support bracket	Fixation du support	2	103068
12	Cap	Capuchon	2	105407
13	Wire assembly	Fil assemblé	1	104017
14	Wire assembly	Fil assemblé	1	104018
15	Wire Assembly	Fil Assemblé	1	106548
16	Wire Assembly	Fil assemblé	1	106558
17	Engine 23 Hp (Kohler)	Moteur 23 CV (Kohler)	1	REF
18	Hex. bolt 1/4" n.c. x 1/2" GR5	Boulon hex. 1/4" n.c. x 1/2" GR5	5	O/L
19	Hex. bolt 1/4" n.c. x 1 1/2" GR5	Boulon hex. 1/4" n.c. x 1 1/2" GR5	2	O/L
20	Hex. bolt 5/16" n.f. x 3/4" GR5	Boulon hex. 5/16" n.f. x 3/4" GR5	4	O/L
21	Hex. bolt 3/8" n.c. x 2" GR5	Boulon hex. 3/8" n.c. x 2" GR5	4	O/L
22	Flange nut 1/4" n.c.	Écrou à bride 1/4" n.c.	2	O/L
23	Flange nut 5/16" n.c.	Écrou à bride 5/16" n.c.	2	O/L
24	Nylon Insert lock Nut 3/8" n.c.	Écrou à garniture de nylon 3/8" n.c.	4	O/L
25	Nylon insert locknut #8 x 32 (thin) GR2	Écrou à garni. de nylon #8 x 32 (mince) GR2	4	O/L
26	Flat washer #10 hole	Rondelle plate #10 trou	2	O/L
27	Flat washer 1/4" hole	Rondelle plate 1/4" trou	2	O/L
28	Flat washer 5/16" hole	Rondelle plate 5/16" trou	3	O/L
29	Flat washer 7/16" hole	Rondelle plate 7/16" trou	8	O/L
30	Lock washer 1/4"	Rondelle de blocage 1/4"	3	O/L

O/L = Obtain Locally

PARTS LIST

SNOWBLOWER WITH 23HP KOHLER ENGINE

Ref. Réf.	English description	Description française	Qty. Qté.	Part # Pièce #
31	Machine screw Pan head no.8 x 32 x 5/8"	Vis mécanique à tête Pan no.8 x 32 x 5/8"	4	O/L
32	Machine screw Pan head no.10 x 32 x 1 1/2"	Vis mécanique tête pan no.10 x 32 x 1 1/2"	2	O/L
33	Tie wrap 8"	Attache de nylon 8"	12	O/L
34	Specifications decal	Décalque spécifications	1	REF
35	Serial number	Numéro de série	1	REF
36	Made in Canada decal	Décalque Fabriqué au Canada	1	REF

O/L = Obtain Locally

PARTS BREAKDOWN

54" PRESTIGE SNOWBLOWER #700360-10

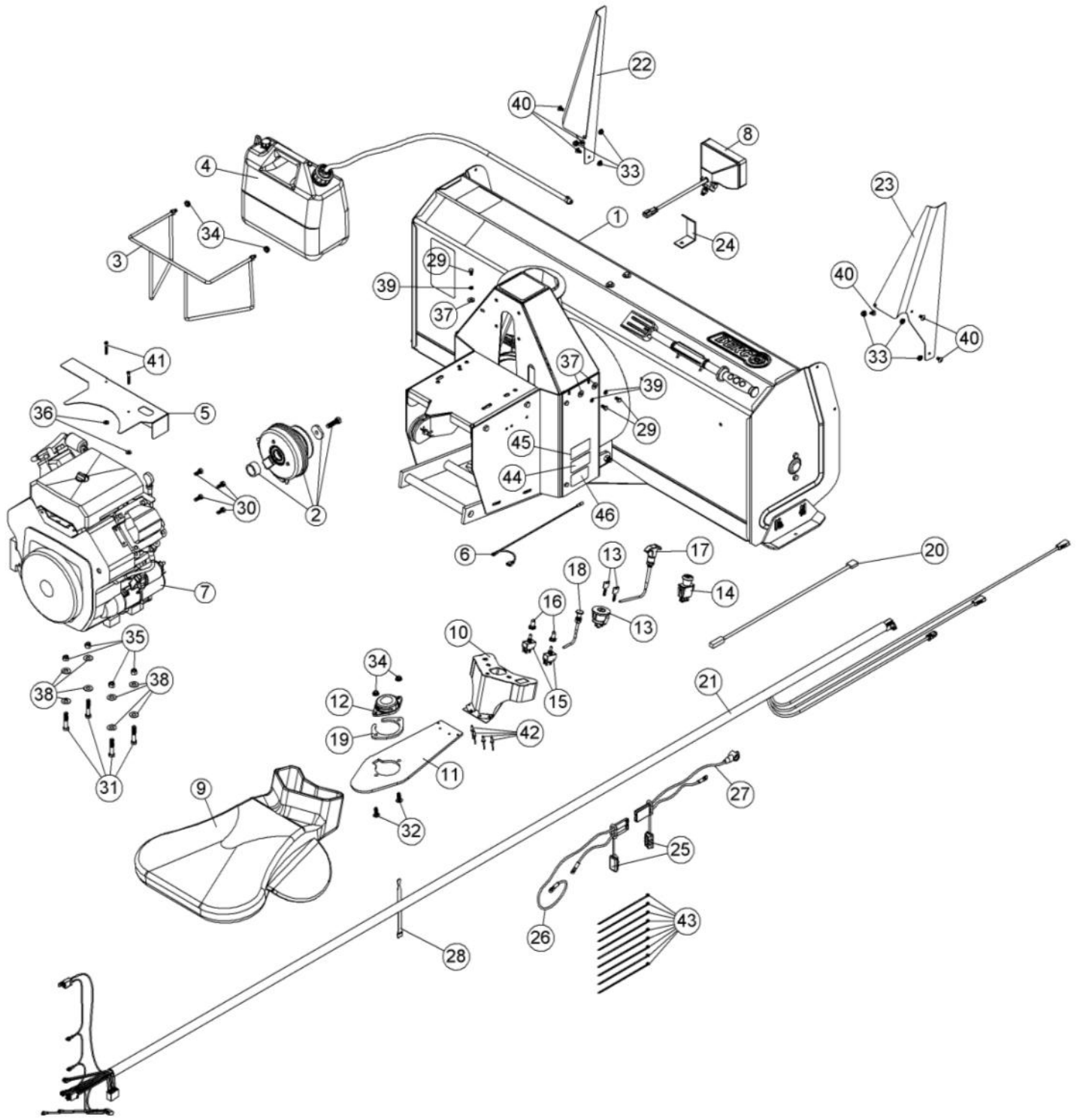

PARTS LIST

54" PRESTIGE SNOWBLOWER #700360-10

Ref. Réf.	English description	Description française	Qty. Qté.	Part # Pièce #
1	Snowblower 54"	Souffleuse à neige 54"	1	700582-1-SM
2	Electric Clutch Assembly (Hole 1 1/8")	Embrayage électrique ass. (Alésage 1 1/8")	1	106179
3	Tank support	Support de réservoir	1	104792
4	Gasoline tank assembly	Réservoir d'essence assemblé	1	104005
5	Heat shield	Pare-chaleur	1	104621
6	Wire assembly	Fil assemblé	1	105218
7	Engine 23 HP (Kohler)	Moteur 23 CV (Kohler)	1	104003
8	Light Assembly	Lumière Assemblée	1	106583
9	Seat cover	Couvre-siège	1	103987
10	Control board	Tableau de contrôle	1	104011
11	Switch support	Support de commutateur	1	104012
12	Safety switch ass'y	Commutateur de sécurité ass'é	1	104014
13	Ignition switch	Commutateur d'ignition	1	104015
14	P.T.O. switch	Commutateur de p.d.f.	1	104016
15	Switch	Commutateur	2	103381
16	Rubber boot	Capuchon de caoutchouc	2	103379
17	Throttle control	Contrôle de l' accélérateur	1	106603
18	Choke control	Contrôle de l' étrangleur	1	106604
19	Shim	Cale	1	104013
20	Wire Assembly	Fil Assemblé	1	106548
21	Wire Assembly	Fils Assemblés	1	106544
22	Left drift cutter	Couteau à neige gauche	1	102821
23	Right drift cutter	Couteau à neige droit	1	102822
24	Light bracket	Fixation de la lumière	1	104791
25	Cap	Capuchon	2	105407
26	Wire assembly	Fil assemblé	1	104017
27	Wire assembly	Fil assemblé	1	104018
28	Hook-it cable ties	Attache câble auto-grippante	1	104408
29	Hex. bolt 1/4" n.c. x 1/2" GR5	Boulon hex. 1/4" n.c. x 1/2" GR5	3	O/L
30	Hex. bolt 5/16" n.f. x 3/4" GR5	Boulon hex. 5/16" n.f. x 3/4" GR5	4	O/L

O/L = Obtain Locally

PARTS LIST
54" PRESTIGE SNOWBLOWER #700360-10

Ref. Réf.	English description	Description française	Qty. Qté.	Part # Pièce #
31	Hex. bolt 3/8" n.c. x 2" GR5	Boulon hex. 3/8" n.c. x 2" GR5	4	O/L
32	Carriage bolt 5/16" n.c. x 1 " GR5	Boulon à carrosserie 5/16" n.c. x 1 " GR5	2	O/L
33	Flange nut 1/4" n.c.	Écrou à bride 1/4" n.c.	6	O/L
34	Flange nut 5/16" n.c.	Écrou à bride 5/16" n.c.	4	O/L
35	Nylon Insert lock Nut 3/8" n.c.	Écrou à garniture de nylon 3/8" n.c.	4	O/L
36	Flat washer 1/4" hole	Rondelle plate 1/4" trou	2	O/L
37	Flat washer 5/16" hole	Rondelle plate 5/16" trou	3	O/L
38	Flat washer 7/16" hole	Rondelle plate 7/16" trou	8	O/L
39	Lock washer 1/4"	Rondelle de blocage 1/4"	3	O/L
40	Machine screw T.H. 1/4" n.c. x 1/2"	Vis mécanique T.H. 1/4" n.c. x 1/2"	6	O/L
41	Machine screw Pan head no.10 x 32 x 1 1/2"	Vis mécanique tête pan no.10 x 32 x 1 1/2"	2	O/L
42	Pop-rivet 3/16" no AD-66BS	Rivet pop 3/16 no.AD-66BS	4	O/L
43	Tie wrap 8"	Attache de nylon 8"	9	O/L
44	Specifications decal	Décalque spécifications	1	REF
45	Serial number	Numéro de série	1	REF
46	Made in Canada decal	Décalque Fabriqué au Canada	1	REF

O/L = Obtain Locally

PARTS BREAKDOWN EXPLOSIVE VIEW

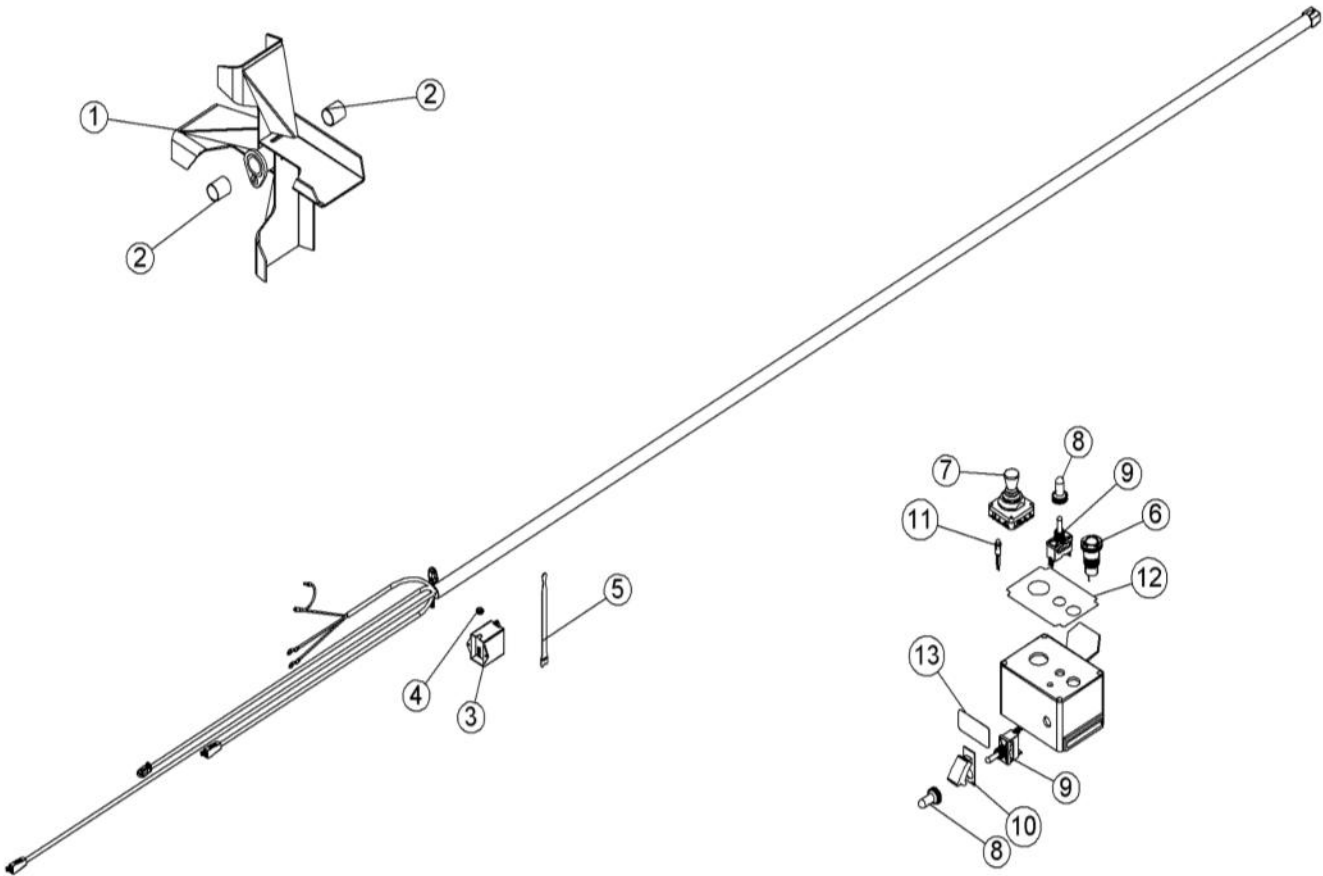

PARTS LIST
105560 - FAN WITH BUSHING - ÉVANTAIL AVEC COUSSINET

Ref. Réf.	English description	Description française	Qty. Qté.	Part # Pièce #
1	Fan	Éventail	1	103932
2	Oil lite bushing	Coussinet imprégné d'huile	2	102784

PARTS LIST
106558 - WIRE ASSEMBLY - FILS ASSEMBLÉS

Ref. Réf.	English description	Description française	Qty. Qté.	Part # Pièce #
3	Relay socket	Socle pour relais	1	106559
4	Rubber grommet	Oeillet de caoutchouc	1	106563
5	Hook-it cable ties	Attache câble auto-grippante	1	104408

PARTS LIST
106564 - Control box assembly - Boîte de contrôle assemblée

Ref. Réf.	English description	Description française	Qty. Qté.	Part # Pièce #
6	Emergency switch	Interrupteur d'urgence	1	105726
7	Joystick 4 positions	Levier de commande 4 positions	1	106160
8	Rubber boot	Capuchon de caoutchouc	2	106129
9	Switch	Commutateur	2	106182
10	Switch Guard	Garde du Commutateur	1	106177
11	Indicator light	Voyant lumineux	1	106561
12	Control box decal	Décalque de la boîte de contrôle	1	106121
13	Clutch decal	Décalque d'embrayage	1	106281

O/L = Obtain Locally

TORQUE SPECIFICATION TABLE

GENERAL TORQUE SPECIFICATION TABLE USE THE FOLLOWING TORQUES WHEN SPECIAL TORQUES ARE NOT GIVEN

NOTE: These values apply to fasteners as received from supplier, dry or when lubricated with normal oil. They do not apply if special graphited or moly disulphide greases or other extreme pressure lubricants are used. This applies to both UNF and UNC threads.

* Thick nuts must be used with grade 8 bolts

SEE Grade No.		2				5				8 *			
BOLT HEAD IDENTIFICATION MARKS AS PER GRADE NOTE MANUFACTURING MARKS WILL VARY		TORQUE				TORQUE				TORQUE			
BOLT SIZE		FOOT POUNDS		NEW TON-METERS		FOOT POUNDS		NEW TON-METERS		FOOT POUNDS		NEW TON-METERS	
Inches	Millimetre	Min.	Max.	Min.	Max.	Min.	Max.	Min.	Max.	Min.	Max.	Min.	Max.
1/4"	6.35	5	6	6.8	8.13	9	11	12.2	14.9	12	15	16.3	30.3
5/16"	7.94	10	12	13.6	16.3	17	20.5	23.1	27.8	24	29	32.5	39.3
3/8"	9.53	20	23	27.1	31.2	35	42	47.5	57	45	54	61	73.2
7/16"	11.11	30	35	40.7	47.4	54	64	73.2	86.8	70	84	94.9	113.9
1/2"	12.7	45	52	61	70.5	80	96	108.5	130.2	110	132	149.2	179
9/16"	14.29	65	75	88.1	101.6	110	132	149.2	179	160	192	217	260.4
5/8"	15.88	95	105	128.7	142.3	150	180	203.4	244.1	220	264	298.3	358
3/4"	19.05	150	185	203.3	250.7	270	324	366.1	439.3	380	456	515.3	618.3
7/8"	22.23	160	200	216.8	271	400	480	542.4	650.9	600	720	813.6	976.3
1"	25.4	250	300	338.8	406.5	580	696	786.5	943.8	900	1080	1220.4	1464.5

METRIC BOLT TORQUE SPECIFICATIONS							
		COARSE THREAD			FINE THREAD		
Size Screw	Grade No.	Pitch (mm)	Foot Pounds	Newton-Meters	Pitch (mm)	Foot Pounds	Newton-Meters
M6	4T	1.00	3.6 - 5.8	4.9 - 7.9	-	-	-
	7T		5.8 - 9.4	7.9 - 12.7		-	-
	8T		7.2 - 10	9.8 - 13.6		-	-
M8	4T	1.25	7.2 - 14	9.8 - 19	1.00	12 - 17	16.3 - 23
	7T		17 - 22	23 - 29.8		19 - 27	25.7 - 36.6
	8T		20 - 26	27.1 - 35.2		22 - 31	29.8 - 42
M10	4T	1.50	20 - 25	27.1 - 33.9	1.25	20 - 29	27.1 - 39.3
	7T		34 - 40	46.1 - 54.2		35 - 47	47.4 - 63.7
	8T		38 - 46	51.5 - 62.3		40 - 52	54.2 - 70.5
M12	4T	1.75	28 - 34	37.9 - 46.1	1.25	31 - 41	42 - 55.6
	7T		51 - 59	69.1 - 79.9		56 - 68	75.9 - 92.1
	8T		57 - 66	77.2 - 89.4		62 - 75	84 - 101.6
M14	4T	2.00	49 - 56	66.4 - 75.9	1.50	52 - 64	70.5 - 86.7
	7T		81 - 93	109.8 - 126		90 - 106	122 - 143.6
	8T		96 - 109	130.1 - 147.7		107 - 124	145 - 168
M16	4T	2.00	67 - 77	90.8 - 104.3	1.50	69 - 83	93.5 - 112.5
	7T		116 - 130	157.2 - 176.2		120 - 138	162.6 - 187
	8T		129 - 145	174.8 - 196.5		140 - 158	189.7 - 214.1
M18	4T	2.00	88 - 100	119.2 - 136	1.50	100 - 117	136 - 158.5
	7T		150 - 168	203.3 - 227.6		177 - 199	239.8 - 269.6
	8T		175 - 194	237.1 - 262.9		202 - 231	273.7 - 313
M20	4T	2.50	108 - 130	146.3 - 176.2	1.50	132 - 150	178.9 - 203.3
	7T		186 - 205	252 - 277.8		206 - 242	279.1 - 327.9
	8T		213 - 249	288.6 - 337.4		246 - 289	333.3 - 391.6

OPTIONS & ACCESSORIES

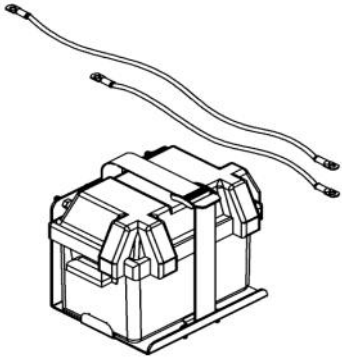

#700524
SUPPORT FOR BATTERY
(BATTERY NOT INCLUDED)
 For ATV or UV



#700260
SNOW DRIFT CUTTER
 Slices through high snow drifts to facilitate and increase snow intake. Package of 2.

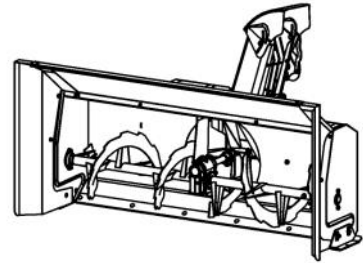

#700461
EXTENSION AND
SIDE WIDENING ANGLES KIT
 Widens the snowblower to 60"

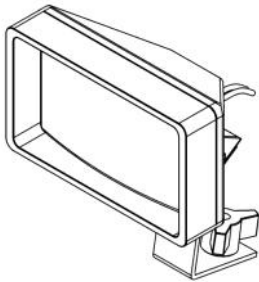

#700456-1
LIGHT KIT
 Better visibility for night time use

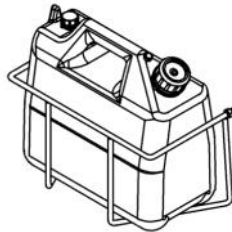

#700462
GAS TANK KIT
 Handy for easy re-fuelling

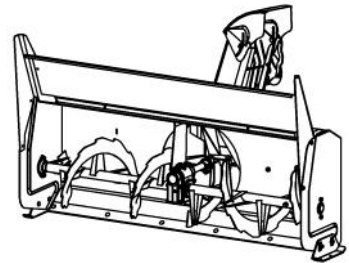

#700473
EXTENSION
 Adds 8" to the height of the snowblower
REQUIRES #700260

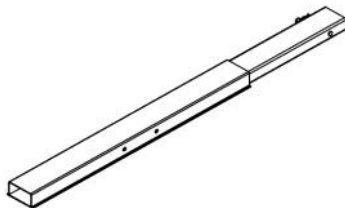

SUBFRAME EXTENSION
#700485
 For bigger vehicle

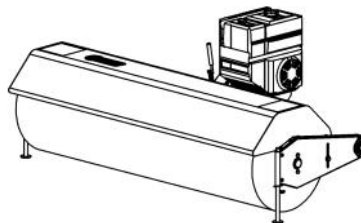

#700448
60" ROTARY BROOM
 For ATV or UV



***WHEN PERFORMANCE
& DEPENDABILITY
ARE NON NEGOTIABLE !***

**Bercomac Limitée
92, Fortin North, Adstock, Quebec, Canada, G0N 1S0**

WWW.BERCOMAC.COM

PRINTED IN CANADA

(ORIGINAL NOTICE)