



OWNER'S MANUAL
Model Number

700796 Subframe with Winch
700797 Northeast Drive Mechanism
700798 Compact Drive Mechanism



BERCO
Subframe with Electric Lift & Drive Mechanism
for
CUB CADET XT1 & XT2

* ASSEMBLY
* OPERATION

* REPAIR PARTS
* MAINTENANCE

CAUTION:
READ & FOLLOW ALL SAFETY RULES & INSTRUCTIONS BEFORE
OPERATING YOUR EQUIPMENT



LIMITED WARRANTY

Conditions and Products Covered:

BERCOMAC guarantees any part of the product or accessory manufactured by BERCOMAC and found in the reasonable judgment of BERCOMAC to be defective in material and or workmanship will be repaired or replaced by an authorized dealer without charge up to our maximum labor rates and pre-established times. For replacement parts only standard ground freight services are covered. This warranty extends to the original retail purchaser only and is not transferable to any subsequent purchasers. This warranty applies to the products bought and used in North America.

Warranty Period

(from date of the original retail purchase)

- Residential use: 1 year
- Semi-commercial, professional or rental use: 90 days

Exceptions Noted Below; the following items are guaranteed by the original manufacturer and have their own warranty, conditions and limited time:

- Tire Chains: 90 days
- Engines: Will vary as per the manufacturer
Please refer to the engine manufacturer's warranty statement included with the unit. BERCOMAC is not authorized to handle warranty adjustments on engines.

Items and Conditions NOT Covered:

This warranty does not cover the following:

- Pick-up or delivery charges or in-home services fees.
- Any damage or deterioration of the unit, parts and or finish of these due to normal use, wear and tear, or exposure.
- Cost of regular use or maintenance service or parts, such as gas, oil, lubricants, tune-up parts, and adjustments.
- Any part or accessory which has been altered, modified, misused, neglected, accidentally damaged or not properly installed, maintained, stored or repaired not in accordance with the instructions in the owner's manual.
- Repair due to normal wear and or any wear items such as shear pins, bolts, belts, etc.
- Expedited freight fee services for replacement parts.
- Shear bolts and shear pins are to be considered as a preventive measure not as an assured protection, any damages resulting from the lack of shear bolts breakage are not covered.
- Damages due to product being installed on a vehicle other than stipulated in owner's manual.

NOTE: All warranty work must be performed by an authorized dealer using original (manufacturer) replacement parts.

NOTE: Bercomac reserves the right to change or improve the design of any part or accessory without assuming any obligation to modify any product previously manufactured.

Instructions for Obtaining Warranty Services:

Contact dealer where equipment was purchased or any other BERCO service dealer to arrange service at their dealership. Requests for warranty claims must be carried out through the same distribution network used to purchase the product. Don't forget to bring your proof of purchase (sales receipt) to the BERCOMAC dealer.

Owner's Responsibilities:

BERCOMAC's defective equipment or part must be returned to an authorized dealer within the warranty period for repairs. In the event that defective merchandise must be returned to manufacturer for repairs, freight fees are prepaid and a written authorization from BERCOMAC must be obtained by dealer prior to the shipment. This warranty extends only to equipment operated under normal conditions. To validate a warranty claim, it is the user's responsibility to maintain and service the unit as specified in the owner's manual or to have the unit serviced at their dealer at their expense.

General Conditions:

The sole liability of BERCOMAC with respect to this warranty shall be strictly and exclusively repair and replacement as mentioned herein. BERCOMAC shall not have any liability for any other costs, loss or damage, including but not limited to, any incidental or consequential loss or damage. Taking advantage of the warranty does not in any way extend the length or renewal of the warranty.

In particular, without being limited to, BERCOMAC shall have no liability or responsibility for:

- Travel time, overtime, after hours time or other extraordinary repair charges or relating to repairs and or replacements outside of normal business hours.
- Rental of like or similar replacement equipment during the period of any, repair or replacement work.
- Any communicating or travel charges.
- Loss or damage to person or property other than that covered by the terms of this warranty.
- Any claims for lost revenue, lost profit or any similar costs as a result of damage or repair.
- Attorney's fees.

BERCOMAC's responsibility in respect to claims is limited to making the required repairs or replacement without charge up to our maximum labor rates and pre-established times and no claim of breach of warranty shall be cause for cancellation or rescission of the contract of sale of any product or accessory. In no event recovery of any kind be greater than the amount of the purchase price of the product sold.

This warranty gives you specific legal rights. You may also have other rights, which vary from state to state.

TABLE OF CONTENTS

	PAGE
INTRODUCTION	2
SAFETY PRECAUTIONS	3
SAFETY DECALS	5
ASSEMBLY	
Tools Required	6
Step 1: Subframe Installation	6
Step 2: Winch Control Switch Installation	9
Step 3: Drive Mechanism Installation	12
OPERATION & MAINTENANCE	
Controls	15
Maintenance	15
Belt Replacement	15
Verify Tire Pressure	15
DISMOUNTING & STORAGE	
Dismounting	15
Storage	15
TROUBLE SHOOTING	16
PARTS BREAKDOWN AND PARTS LIST	
Subframe 700796	18
Northeast Drive Mechanism 700797	20
Compact Drive Mechanism 700798	21
Sub assemblies	22
TORQUE SPECIFICATION TABLE	28
ATTACHMENTS	29

INTRODUCTION

TO THE PURCHASER

This new accessory was carefully designed to give years of dependable service. This manual has been provided to assist in the safe operation and servicing of your attachment.

NOTE: All photographs and illustrations in the manual may not necessarily depict the actual models or attachment, but are intended for reference only and are based on the latest product information available at the time of publication.

Familiarize yourself fully with the safety recommendations and operating procedures before putting the machine to use. Carefully read, understand and follow these recommendations and insist that they be followed by those who will use this attachment.



THIS SAFETY ALERT SYMBOL IDENTIFIES AN IMPORTANT SAFETY MESSAGE IN THIS MANUAL THAT HELPS YOU AND OTHERS AVOID PERSONAL INJURY OR EVEN DEATH. DANGER, WARNING, AND CAUTION ARE SIGNAL WORDS USED TO IDENTIFY THE LEVEL OF HAZARD. HOWEVER, REGARDLESS OF THE HAZARD, BE EXTREMELY CAREFUL.

DANGER: Signals an extreme hazard that will cause serious injury or death if recommended precautions are not followed.

WARNING: Signals a hazard that may cause serious injury or death if the recommended precautions are not followed.

CAUTION: Signals a hazard that may cause minor or moderate injury if the recommended precautions are not followed.

Record your attachment serial number and purchase date in the section reserved below (there is no serial number on the subframe). Your dealer requires this information to give you prompt, efficient service when ordering replacement parts. Use only genuine parts when replacements are required.

If warranty repairs are required please present this registration booklet and original sales invoice to your selling dealer for warranty service.

This manual should be kept for future reference.

Please check if you have received all the parts for your kit with the list of the bag and the list of the box.

SERIAL NUMBER : _____
(IF APPLICABLE)

MODEL NUMBER: _____

PURCHASE DATE : _____



SAFETY PRECAUTIONS



Careful operation is your best insurance against an accident. Read this section carefully before operating the vehicle and accessory. This accessory is capable of amputating hands and feet and throwing objects. Failure to observe the following safety instructions could result in serious injury. All operators, no matter how experienced they may be, should read this and other manuals related to the vehicle and accessory before operating. It is the owner's legal obligation to instruct all operators in safe operation of the accessory to prevent accidents or injuries.

These are common practices that may or may not be applicable to the product described in this manual.

GLOSSARY:

In this manual, right and left sides are determined by sitting on the seat of the vehicle facing forward.

In this manual, "accessories" means attachments (snowblower, rotary broom, blade, etc.) that you install on the vehicle (lawn tractors, A.T.V. s etc).

TRAINING:



This symbol, "Safety Alert Symbol", is used throughout this manual and on the accessory's safety labels to warn of the possibility of serious injury. Please take special care in reading and understanding the safety precautions before operating the vehicle and accessory.

1. Read this owner's manual carefully. Be thoroughly familiar with the controls and proper use of the vehicle and accessory. Know how to stop the unit and disengage the controls quickly.
 2. Never allow children to operate the vehicle nor the accessory. Never allow adults to operate the vehicle nor the accessory without proper instructions. Local regulations restrict the age of the operator. Children are often attracted to accessories. Never assume children will stay in place where you have last seen them. Keep children under surveillance of a responsible adult at all times.
 3. No one should operate the vehicle nor the accessory while intoxicated or while taking medication that impairs the senses or reactions. The operator should, if taking over the counter drugs, seek medical advice on whether he/she can safely operate the equipment.
 4. Keep the area of operation clear of all people, particularly small children and pets.
 5. Never start or operate the accessories except from the operator's station on the power unit except if this is impossible.
4. Do not operate the accessory without wearing adequate clothing and safety equipment. Long hair, loose clothing or jewelry can get caught in moving parts. Wear footwear that will improve footing on slippery surfaces.
 5. Handle fuel with care, it is highly flammable and vapors are explosive.
 - a) Extinguish all cigarettes, cigars, pipes and other sources of ignition.
 - b) Use approved fuel container.
 - c) Never add fuel to a running engine or hot engine.
 - d) Fill fuel tank outdoors with extreme care. Never fill fuel tank indoors.
 - e) Never fill containers inside a vehicle, or on a truck or a trailer bed with a plastic liner. Always place containers on the ground, away from your vehicle, before filling.
 - f) When practical, remove gas-powered equipment from the truck or trailer and refuel it on the ground. If this is not possible, then refuel such equipment on a trailer with a portable container, rather than directly from a gasoline dispenser nozzle.
 - g) Keep the nozzle in contact with the rim of the fuel tank or container opening at all times, until refueling is complete. Do not use a nozzle lock-open device.
 - h) Never overfill fuel tank. Replace fuel cap securely and wipe up spilled fuel.
 - i) If fuel is spilled on clothing, change clothing immediately.
 6. Never attempt to make any adjustments while the engine (motor) is running (except when specifically recommended by manufacturer).
 7. Let the vehicle and accessory adjust to outdoor temperatures before using.
 8. Never use an accessory without proper guards, plates, or other safety protective devices in place
 9. Always make sure to wear the appropriate safety equipment required (glasses, muffs, mask...) for each type of product. See operation section.
 10. Always make sure of having safe traction on the vehicle by using the recommended accessories (chains, A.T.V. tracks, counterweights...). See operation section.
 11. Always make sure all components are correctly installed. (driveline securely attached and locked at both ends, belts properly installed...)
 12. If applicable, always handle the winch cable with thick leather gloves.
 13. **Never modify the accessory or any part without the written consent from the manufacturer.**

PREPARATION:

1. Thoroughly inspect the area where the accessory is to be used and remove door mats, all foreign objects and the like which could be pick up and projected by accessory.
2. For motorized accessories, disengage all clutches and shift into neutral before starting engine.
3. Prepare for emergencies. Be prepared if a fire starts. Keep first aid kit and fire extinguisher handy. Keep emergency phone numbers (doctor, ambulance, ect) near a phone



SAFETY PRECAUTIONS



OPERATION:

1. Do not put hands or feet near, under or inside rotating parts.
2. Exercise extreme caution when operating on or crossing gravel drives, walks or roads. Stay alert for hidden hazards or traffic. Do not carry passengers.
3. After striking a foreign object, stop the engine (motor), disconnect the wire from the spark plug(s) and keep wire away to prevent accidental starting. Thoroughly inspect the accessory for any damage and repair damage before restarting and using the accessory.
4. If the unit should start to vibrate abnormally, stop the engine (motor) and check immediately for the cause. Vibration is generally a warning of trouble. Do not use equipment until properly repaired.
5. Take all possible precautions when leaving the vehicle unattended. Disengage the power take-off, lower the attachment, place the transmission into neutral, set the parking brake, stop the engine and remove the ignition key.
6. Do not run the engine indoors, except when starting the engine and for transporting in or out of the building. Do not operate or let motor run in a storage area without ventilation because gas contains carbon monoxide which is odorless, colorless and can cause death.
7. Never use the accessories across the face of slopes, go from top to bottom. Exercise extreme caution when using equipment on slopes, on wet ground or near drop-off. Do not attempt to use accessory on a steep slope.
8. Never tolerate bystanders in the working zone. Never use an accessory in the direction of bystanders, it might throw gravel or debris that can hurt people or damage property.
9. Never operate the accessory at high transport speeds on slippery surfaces. Use care when backing up.
10. Do not carry passengers.
11. Disengage power to the accessory when it is transported or not in use.
12. Never operate the accessory without good visibility or light.
13. Keep the accessory away from heat sources or flames.
14. If applicable, never handle the winch cable or hook while under tension.
15. Never use accessory if it has been dropped or damaged. Repair if necessary before re-using.

MAINTENANCE AND STORAGE

1. When cleaning, repairing or inspecting the vehicle and accessory: park on a solid level ground, disengage drives, lower implement, set parking brake, stop the engine, remove ignition key, and wait that all moving parts have stopped. For gasoline engine, disconnect wire from the spark plug(s) and keep wire away to prevent accidental starting.
2. Check all the bolts and components at frequent intervals to make sure that they are properly tightened and in safe working condition.
3. Never store a motorized accessory with fuel in the fuel tank inside a building where ignition sources are present such as hot water and space heaters, clothes dryers, and the like. Allow the engine to cool before storing in any enclosure.
4. Always refer to the owner's manual when you store the accessory and vehicle for a prolonged or an unspecified length of time.
5. Maintain or replace safety and instruction labels, as necessary.
6. For winter accessories, (if applicable), let the engine run for a few minutes after clearing snow in order to prevent the rotary parts from freezing.
7. Inspect the vehicle's and accessory's air filter (if applicable) every day. Clean it or replace it as necessary. Change the oil more often when working in dusty conditions. See the vehicle's and accessory's owner's manual.

TRANSPORT

1. Review Transport Safety instructions in vehicle manual before moving or hauling.
2. Check with local authorities regarding transport on public roads and off road. Obey all applicable laws and regulations.
3. Make sure all lights and reflectors that are required by the local highway and transport authorities (example : SMV (Slow Moving Vehicle)) are in place, are clean, and can be seen clearly by all overtaking and oncoming traffic.
4. Never have the equipment in operation during transport.
5. Always travel at a safe speed.



SAFETY DECALS



REPLACE IF DECALS ARE DAMAGED
SEE PARTS BREAKDOWN FOR DECAL LOCATION

DECAL #105133



Failure to observe these instructions could lead to severe injury or death.

To avoid injury to hands or fingers:

- Always keep hands clear of rope hook loop, hook and fairlead opening during installation, operation and when spooling in or out.
- Always use extreme caution when handling hook and rope during spooling operations.
- Always wear heavy leather gloves when handling rope.
- Keep hands away from the hot surface.

ASSEMBLY

IMPORTANT: TORQUE ALL BOLTS ACCORDING TO TORQUE SPECIFICATION TABLE WHEN STATED: TIGHTEN FIRMLY.

THE WINCH KIT IS TO BE USED ONLY TO LIFT BERCO ACCESSORIES, ANY OTHER USE MAY CAUSE DAMAGE TO THE VEHICLE.

This subframe may be used to install different attachments (see attachments page). Once installed, it may remain permanently on your vehicle.

NOTE: It is not necessary to remove mower deck at this step.

INSTALLING THE REFLECTORS

IMPORTANT: When operating the tractor with the front mounted attachment, install the two red-colored adhesive reflectors on the rear vertical surface of the tractor's fender.

STEP 1

SUBFRAME INSTALLATION:

Refer to parts breakdown section for parts identification.

TOOLS REQUIRED:

Wrenches: 1/2, 3/4, 5/16, 7/16, 9/16, 10mm

Ratchet

Sockets: 2/16, 1/2, 9/16, 3/4, 10mm

Cutting pliers

Pliers

Square head screwdriver: #2, #3

Please sort out and identify all the hardware before starting installation. Lists for the hardware bag and for the box are supplied in each.

Install the left & right supports (item 2) on each side of the vehicle.

Item #	Description	Action
1	Support (qty 2)	Install on each side as shown.
2	Hex bolt 3/8", x 1" (qty 6)	Insert as shown.
3	Flat washer (qty 6)	Insert on the bolts (item 2) as shown.
4	Nylon insert lock nut 3/8" (qty 6)	Do not tighten.

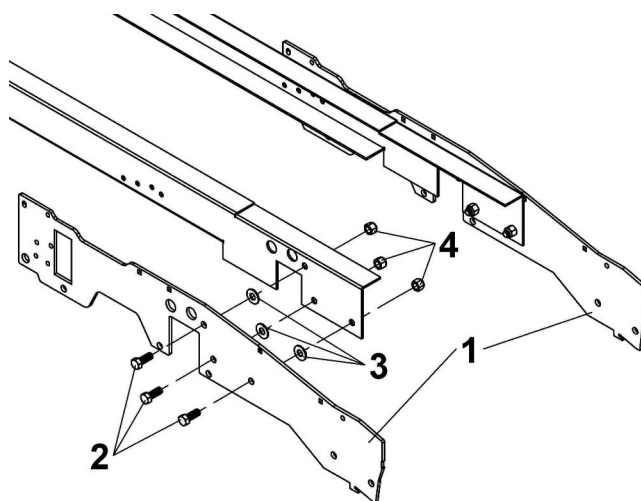

Install the supports

Install the reinforcement plates (item 2) on each side on the supports.

Item #	Description	Action
1	Hex bolt 3/8", x 1" (qty 4)	Install as shown.
2	Reinforcement plates (qty 2)	Install on both sides as shown
3	Nylon insert lock nut 3/8" (qty 4)	Tighten firmly.

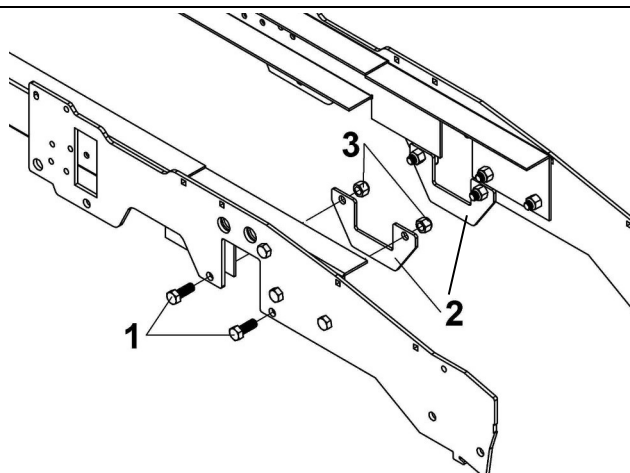

Install the reinforcement plates

ASSEMBLY

Install the handle support (item 3)

Item #	Description	Action
1	J-bolt (qty 2)	The top one: insert as shown. The bottom one: Insert in the sleeve (item 2) and then in the support.
2	Sleeve	Install on the J bolt as shown
3	Handle support	Insert on the J bolt (item 1) as shown.
4	Flat washer	Insert on the J bolt (item 1) as shown.
5	Nylon insert lock nut 1/4" (qty 2)	Tighten until the J bolts are held in place on the frame.
6	Square head set screw 5/16" x 1/2"	Insert as shown.
7	Plastic grommet	Insert as shown.

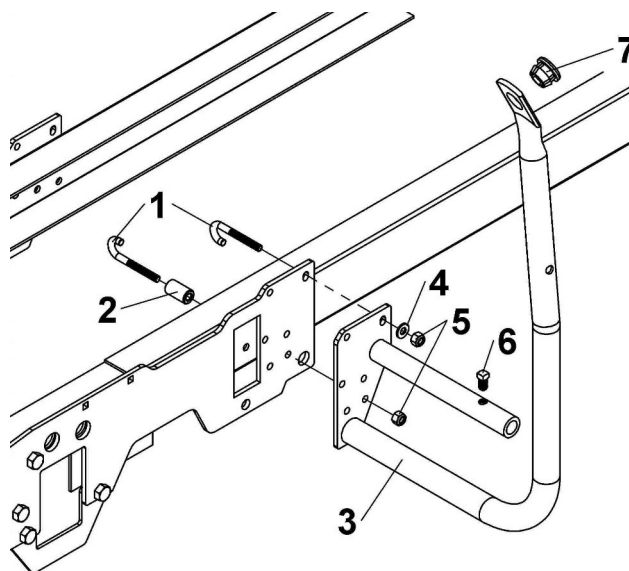

Install handle support

*Make sure the sleeve (item 2) makes contact with the underneath of the frame when the nuts are tightened firmly.

Install the cab support (item 4)

Item #	Description	Action
1	J-bolt (qty 2)	The top one: insert as shown. The bottom one: Insert in the sleeve (item 2) and then in the support..
2	Sleeve	Install on the J bolt as shown
3	Handle support	Insert on the J bolt (item 1) as shown.
4	Flat washer	Insert on the J bolt (item 1) as shown.
5	Nylon insert lock nut 1/4" (qty 2)	Tighten until the J bolts are held in place on the frame.
6	Square head set screw 5/16" x 1/2"	Insert as shown.
7	Plastic grommet	Insert as shown.

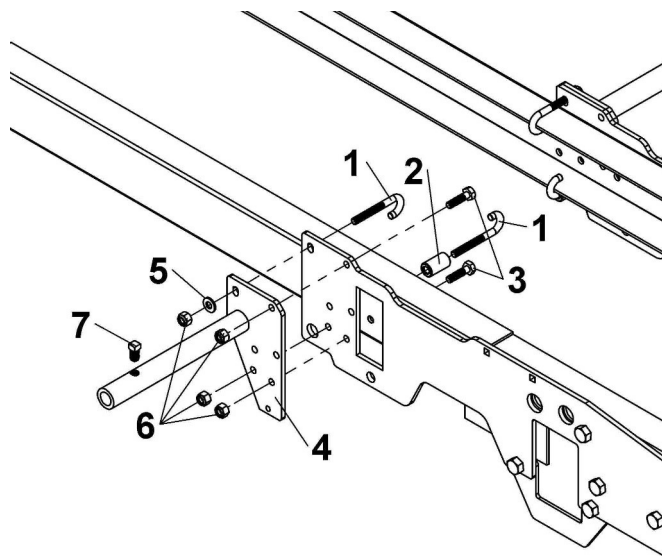

Install the cab support

NOTE: Tighten all the nuts previously installed, after installing the cab support.

ASSEMBLY

Install the motor oil drain hose attaching plate to avoid any damage to the engine's oil hose.

Choose a location **A** or **B** to install the engine's oil hose attaching plate, (not shown, with the tractor) make sure the hose does not become damaged on any sharp edge. If location **B** is chosen, install the bolts anyway in the **A** location.

# Item	Description	Action
1	Hex bolt 1/4" x 1" (qty 2 or 4)	Install as shown.
2	Oil hose attaching plate	Install as shown.
3	Nylon insert lock nuts 3/8" (qty 2 or 4)	Tighten firmly.

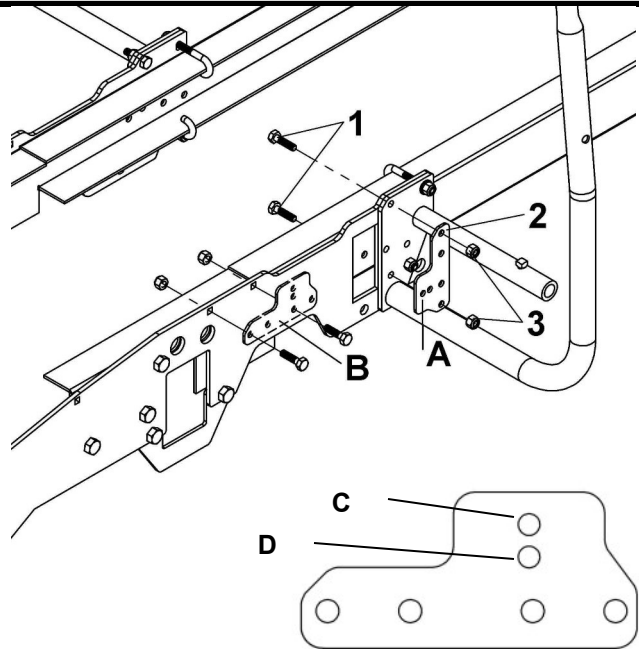

NOTE: If location **A** is chosen, use hole **C**
If location **B** is chosen, use hole **D**

Install the female hitch (item 1)

# Item	Description	Action
1	Female hitch	Install between the two supports.
2	Hex bolt 3/8 x 1" (qty 4)	Insert as shown.
3	Flange nut 3/8" (qty 4)	Tighten all the nuts firmly.

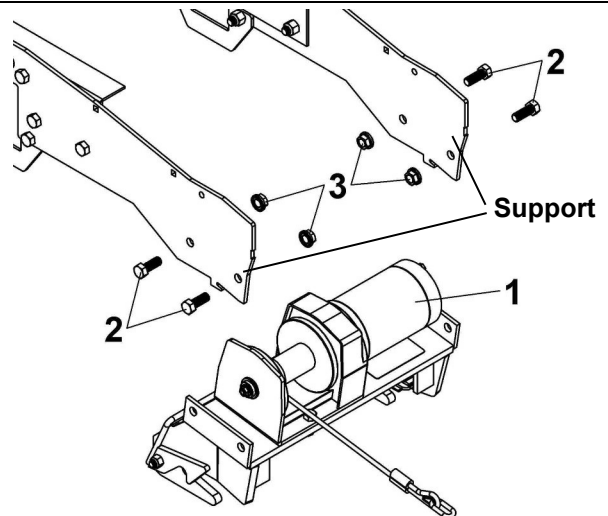

Installer l'attache femelle entre les deux supports

Install the spring (item 1)

# Item	Description	Action
1	Spring	Install the spring on the frame as shown.

NOTE: The latch must move freely.

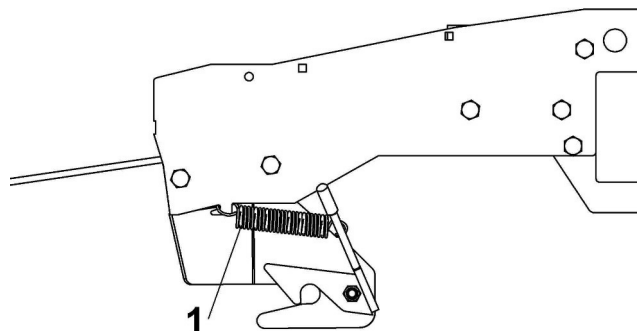

Install the spring as shown

ASSEMBLY

STEP 2: **WINCH CONTROL SWITCH INSTALLATION**

Install the relay (item 1).		
# Item	Description	Action
1	Relay	Install in an appropriate area.
2	Metal screw #12 x 3/4" (qty 4)	Secure relay in place.
*3	Nylon tie wrap 8" (qty 4)	See *
*If necessary use the nylon tie wraps to secure the relay in place. ** Install in a sheltered place away from bad weather.		

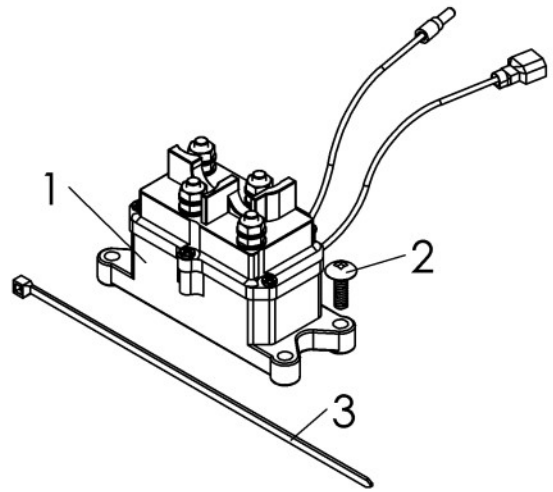

Install the relay

Before drilling the hole, check behind the dashboard to make sure there is enough space to install the switch.

Drill a 1/2" hole in the dashboard or in an appropriate place (see reference drawing). Stick the UP/DOWN decal over the hole for the switch.

Insert the switch in the hole and secure in place with the rubber boot.

NOTE: It is important to install the switch vertically. Connect the wires as shown. When the switch is raised, the winch must lift the accessory. If you prefer the contrary, invert the green and black wires.

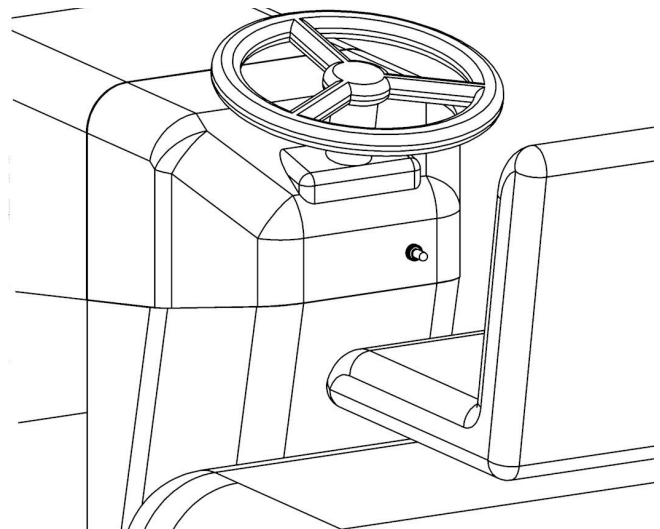

Install the winch control switch

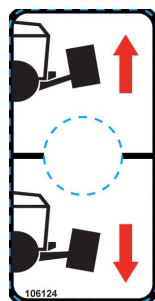

Up / Down decal

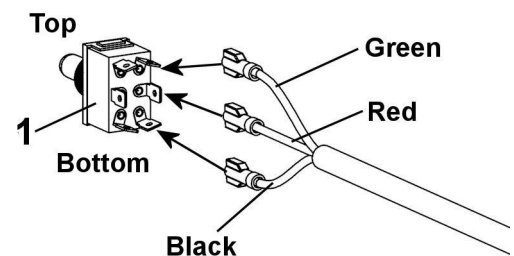

Connect the wires

IMPORTANT

To prolong the winch cable's life, release the winch control switch as soon as the accessory touches the ground. This will keep the cable from tangling up which causes premature wear.

ASSEMBLY

CONNECTING THE WIRES

NOTE: The posts on the relay are identified by colors.

Install the wires on the terminals of the relay.

- Red wire (+) from winch; on blue terminal.
- Black wire (-) from winch; on yellow terminal.
- Red wire (+) from battery; on red terminal.
- Black wire (-) from battery; on black terminal.

Connect the red wire from the winch (limit switch) with the green wire from the relay.

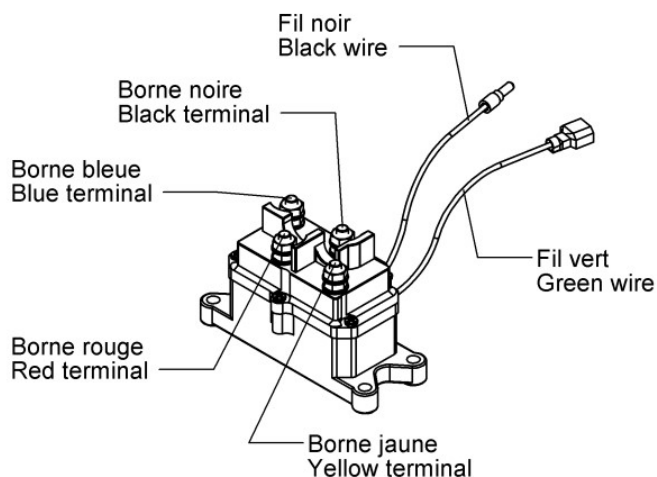

Connect the wires

IDENTIFY THE IGNITION WIRE:

Place the clip of the Hi / Low tester on the negative post (-) on the battery or a metal surface without any paint.

Turn the ignition key to the position: Accessory.

Insert the tip of the tester in a hole at the back of the starter (switch) make sure to touch the metal part of the wire (on most tractors, it is the A1 terminal on the ignition switch that is used for accessories. Before connection, verify with HI/LOW tester).

If the tester's light turns on, turn the ignition key to the position, Off. The light must turn off. You have identified the ignition wire, if not repeat the operation on another wire.

View behind the switch
Vue derrière le commutateur

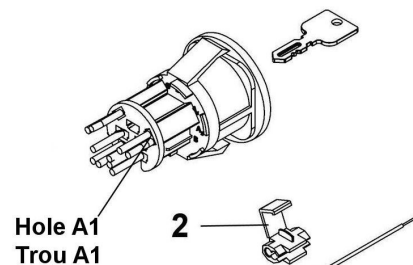
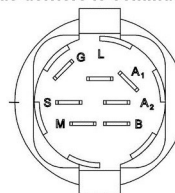

INSTALL THE CONTROL WIRE:

Join the ignition wire and the red wire from the winch control (item 1) with the instant connector (item 2).

Connect the black wire of the winch control (item 3) to the black wire on the relay.

Connect the green wire of the winch control (item 3) with the red wire of the winch (limit switch).

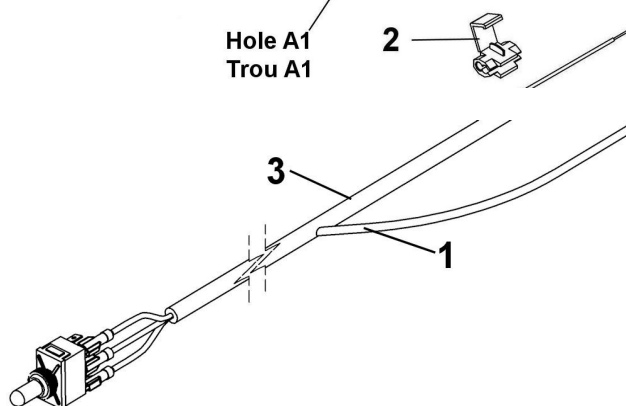

Connect the ignition wire

ASSEMBLY



CAUTION



FOR YOUR SECURITY:
Read and follow the safety precautions for the battery in the vehicle's manual.

CONNECT THE WIRES ON THE BATTERY:

Connect the wires from the relay to the vehicle's battery.
The red wire (+) on the positive post of the battery (item 1).
The black wire (-) on the negative post of the battery (item 2).

Make sure to tighten the nuts on the posts.

TIE ALL THE WIRES:

NOTE: Make sure the wires from the control assembly does not interfere with anything on the tractor nor come into contact with any heating, electrical or removable elements of the tractor.

Tie the wires with four nylon tie wraps included in the kit.

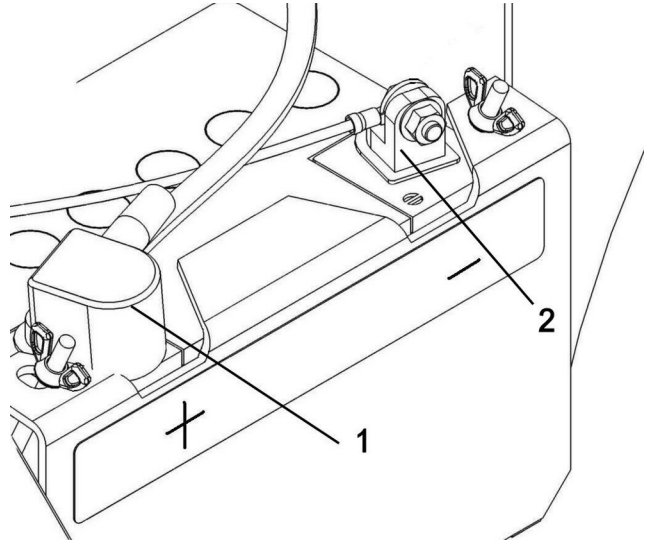

Connect the relay wires to the battery

Install the heat shield (item 1).

# Item	Description	Action
1	Heat shield	Install as shown.
2	Hex bolts 1/4 x 1/2" (qty 2)	Tighten firmly.

VERY IMPORTANT:

Make sure the cable winds up and unrolls as shown in the figure (cable under the spool).
Lubricate the winch cable and the drum periodically with grease.

If the winch cable does not wind up from the bottom of spool as shown, the limit switch will not work and may cause damage to the subframe, winch and accessory.

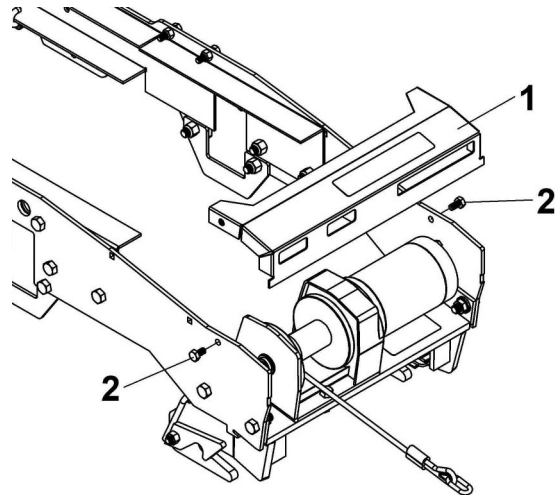

Install the heat shield

ASSEMBLY

STEP 3: DRIVE MECHANISM INSTALLATION:

NOTE: You must remove mower deck to install the drive mechanism.



WARNING



TO PREVENT INJURIES:

It is the person who installs the drive mechanism responsibility to make sure that when the clutch is disengaged that all moving parts stop. For more information, do not hesitate to contact the technical support.



WARNING



TO PREVENT INJURIES:

Stop the motor.
Apply parking brake.
Remove the ignition key.
Disconnect the wire from the spark plug(s) and keep away from spark plug(s) to prevent accidental starting.

Install the drive mechanism (item 1).		
# Item	Description	Action
1	Back of drive mechanism	Hook on the tractor frame, one side at a time, at an angle
2	Front of drive mechanism	Install between the supports as shown.
3	Pin	Insert as shown.
4	Hair pin	Secure the pin.

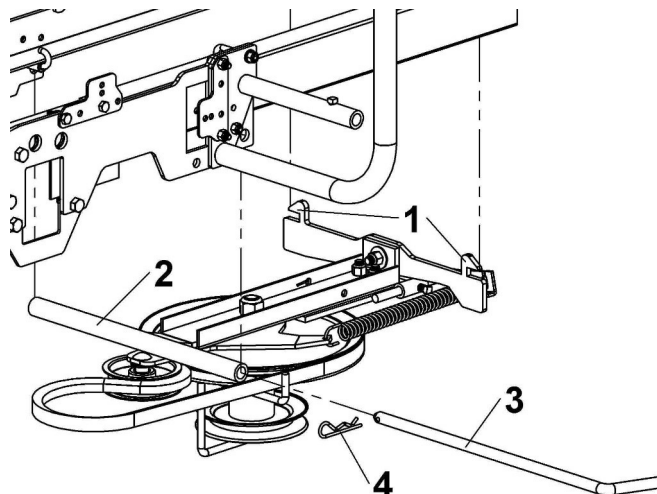

Install drive mechanism

For tractors with Electric Clutch:

Install the belt on the engine pulley of the vehicle.

Check the tension on the spring.

If necessary, adjust the tension by moving the adjustment rod (item 1) and tighten the set screw (item 2).

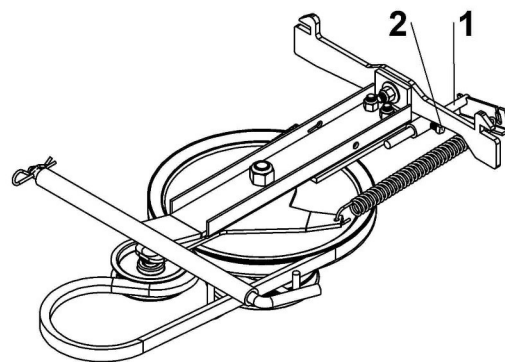

No modifications to be made

ASSEMBLY

For tractors with Manual Clutch activated by a cable:

Install the tractor's manual clutch cable . * Remove the spring.		
NOTE: As shown, you have to back up the adjustment rod support to location A before continuing the installation.		
# Item	Description	Action
1	Spring from the clutch cable	Install as shown in the spring's hook (item 2)
2	Spring's hook	Insert as shown in the hole on the pulley arm.
3	Clutch cable	Insert in the slot on the adjustment rod.
4	Hair pin 2mm	Secure the cable.
5	Adjustment rod	Slide towards the back to apply enough tension on the spring.
6	Square head set screw 5/16 x 1/2"	Secure the adjustment rod.
Install the belt on the engine pulley of the vehicle. Check the tension on the spring. If necessary, adjust the tension by moving the adjustment rod and tighten the set screw.		

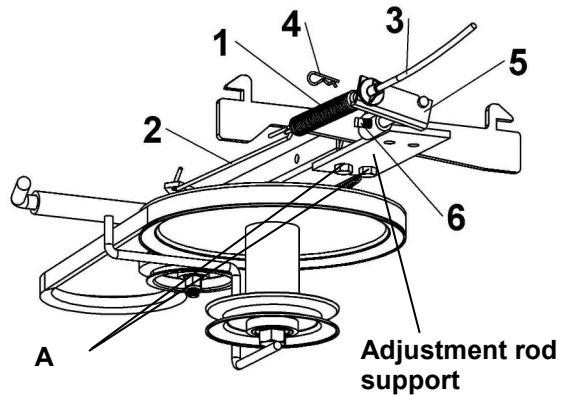

Install the manual clutch cable

NOTE: Remove the existing belt guide and keep to reinstall it with the mower deck

Install the belt guides (items 1 & 2)		
# Item	Description	Action
1 & 2	Belt guides 108078 (right) 108079 (left)	Install as shown in the spring's hook (item 2)
3	Hex bolt 3/8" x 3/4" (qty 2)	Insert as shown.
4	Flat washer (qty 2)	Insert on the bolts (item 3) as shown.
5	Nylon insert lock nut 3/8" (qty 2)	Tighten firmly only when the belt guides are at the right distance, as shown.

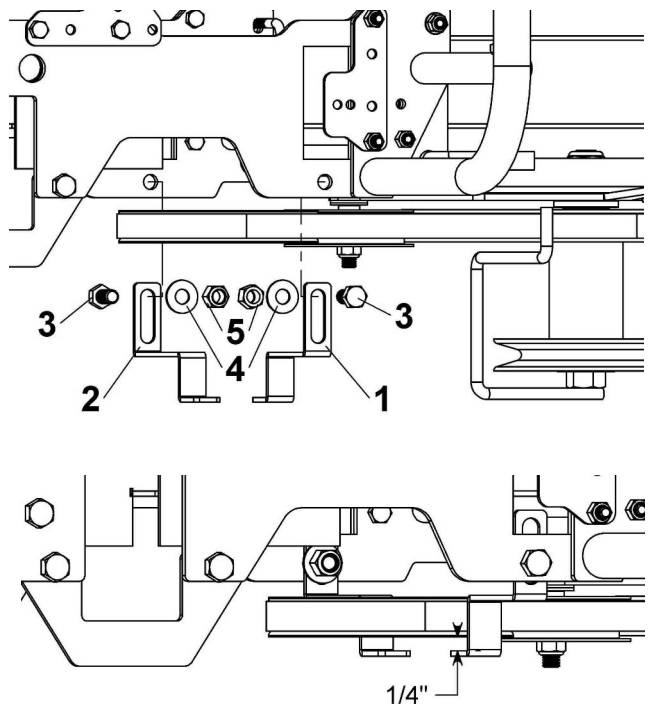

ASSEMBLY

VERIFY THE BELT AND PULLEY ALIGNMENT:



WARNING



TO PREVENT INJURIES:

Do this verification when the vehicle's engine is not running.

If applicable, you can remove or add a flat washer (item 1) on the tension pulley (item 2) for a better adjustment.

Engage and disengage the clutch a few times and make sure the belt does not touch the belt guide in any place when the drive mechanism is engaged.

If the pulley on the drive mechanism is not parallel with the tractor's pulley, adjust the height of the support (item 1).

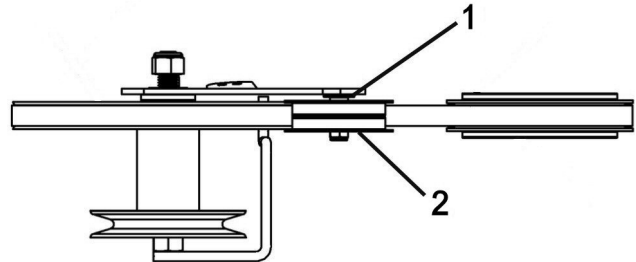

Adjust the pulleys

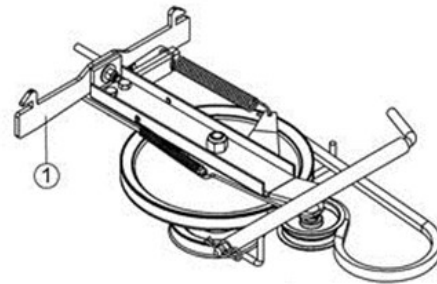

INSTALLATION VALIDATION

In a safe area, without anybody or object around

Engage and disengage at least 10 times to make sure the drive disengage when the clutch is disengaged.

If it does not disengage, add a some washers between the left belt guide and the tractor's frame to bring the tractor's pulley belt guide closer until the engaging and disengaging works correctly.



WARNING



TO PREVENT INJURIES:

It is the person who installs the drive mechanism responsibility to make sure that when the clutch is disengaged that all moving parts stop.

For more information, do not hesitate to contact technical support.

OPERATION & MAINTENANCE



CAUTION



Read the vehicle Owner's Manual carefully. Be thoroughly familiar with the controls & proper use of the attachment. Know how to stop the attachment quickly.

IMPORTANT:
THE WINCH KIT IS TO BE USED ONLY TO LIFT BERCO ACCESSORIES, ANY OTHER USE MAY CAUSE DAMAGE TO THE VEHICLE.

CONTROLS

IMPORTANT:

In order to avoid draining the battery of the vehicle, always start the engine before using the winch.

THE WINCH CONTROL SWITCH

Push up or down the winch control switch to lift or lower the accessory to the ground.

There is a limit switch stopper that limits the lifting. Always prestretch cable and respool under load before installing the hook on the accessory. A tightly wound cable reduces chances of binding, which can cause damage to the cable.

To prolong the winch cable's life, release the winch control switch as soon as the accessory touches the ground. This will keep the cable from tangling up, causing premature wear of the cable.

WINCH CABLE MAINTENANCE

To reduce the risk of cable failure during the season, we recommend changing the winch cable every year. Lubricate the winch cable and the drum periodically with grease.

Install the new winch cable as shown in figure in the parts breakdown.

MAINTENANCE

- Check mounting bolts at frequent intervals for proper tightness to be sure equipment is in safe working condition.
- Apply oil at all pivot points.
- To prolong the life span of the winch, make sure the snap mount switch works well.

BELT REPLACEMENT

Belt for the accessories:

SEE ATTACHMENT OWNER'S MANUAL (SNOWBLOWER AND BROOM) FOR REPLACING INSTRUCTIONS.

Drive Mechanism Belt:

- Dismount the drive mechanism.
- Remove the bolt which retains the tension pulley.
- Replace the belt and re-install the tension pulley. Before tightening make sure the belt guide does not touch the belt at any time.
- Re-install the drive mechanism.
- Check the alignment of the belt that joins the drive mechanism to the engine pulley.

VERIFY TIRE PRESSURE:

Tire pressure must be even on both sides of the tractor according to the vehicle's owner's manual.

DISMOUNTING & STORAGE

DISMOUNTING

SEE ATTACHMENT OWNER'S MANUAL (SNOWBLOWER, BROOM AND BLADE) FOR DISMOUNTING INSTRUCTIONS.

- Dismount the attachment.
- Remove the rear counterweight when you remove the front attachment (if applicable).
- Remove the belt from the engine pulley.
- Dismount the drive mechanism by supporting it in your hand. Carefully lower to the ground.

Manual clutch activated by cable:

Unhook cable shield by removing the hair pin. Unhook spring. Pull out drive mechanism from underneath tractor.

- You may leave the subframe on tractor all year long or remove it if preferred.
- WHEN REINSTALLING THE MOWER DECK, REINSTALL THE ORIGINAL BELT GUIDE.**

STORAGE

- Clean and paint all parts from which paint has worn.
- Apply oil at all pivot points.
- Inspect and replace all defective parts before using again.

TROUBLESHOOTING

* Please refer to parts breakdown section for parts identification.

PROBLEM	POSSIBLE CAUSES	CORRECTIVE ACTION
Winch runs backwards or stays stuck in up position.	Winch wires reversed.	Recheck wiring.
	Switch wires reversed.	Recheck wiring.
	Switch installed incorrectly.	Check switch installation.
	Battery wires reversed.	Recheck wiring.
	Winch cable is not wined up from the bottom of spool.	Wind winch cable from the bottom of the spool. (see assembly section in subframe manual)
Winch will not operate or runs in one direction only.	Vehicle's ignition switch is at OFF position.	Turn vehicle's ignition switch at ON position.
	Broken wires or bad connection.	Check for poor connections.
	Control switch is inoperative.	Replace control switch.
	Relay or breaker is damaged.	Replace the relay or breaker.
	Limit switch is damaged or wires disconnected from limit switch.	Replace limit switch or verify wire connections on limit switch.
	Winch is damaged.	Replace or repair winch.
Winch runs but with insufficient power or line speed.	Weak battery.	Recharge or replace battery. Check charging system
	Poor battery connection.	Check battery terminals for corrosion. Clean when required.
	Winch is damaged.	Replace or repair winch.
Winch cable breaking prematurely.	Frequently stopping the winch when accessory is going down.	Doing complete up and down cycles and avoid stopping midway.
	Cable tangling up.	Release the control switch as soon as the accessory touches the ground.
Winch drum and cable wearing prematurely.	Insufficient lubrication of winch drum and cable.	Lubricate winch drum and cable periodically with grease.
Winch does not hold the accessory in up position.	Winch is damaged.	Replace or repair winch.

TROUBLESHOOTING

HOW TO KNOW	POINTS TO CHECK
Poor connections.	Recheck wiring with the owner's manual
HI/LOW voltage tester does not work.	Connect it on battery posts (+ and -) of a functional battery. If there is no light, the tester is damaged.
The control switch inoperative.	Test both connectors with HI/LOW voltage tester. If light comes ON or the relay is clicking in both positions (UP & DOWN), the control switch is operative.
Relay is damaged	If there is voltage on battery wire posts 1 & 2 on the relay and no voltage on posts 3 & 4 when control switch is activated and relay is clicking in both directions, the relay is defective. (see relay assembly section in owner's manual for relay post identification). Check connections with HI/LOW voltage tester.
Winch is damaged	The ultimate test is to connect the winch directly to the battery and reverse the wires to test both directions. If the winch doesn't work, it is damaged.
The limit switch is damaged.	When the limit switch is pushed or stuck inside, the winch can't raise the accessory, only lower it. If not working properly replace it.
The breaker is damaged.	Place clip of the HI / LOW voltage tester on negative (-) post of the battery. Check the voltage with the tip of the tester on both terminals of the breaker. If voltage only on 1 terminal replace the breaker. (sometimes it could take a few minutes for the breaker to automatically reset itself)

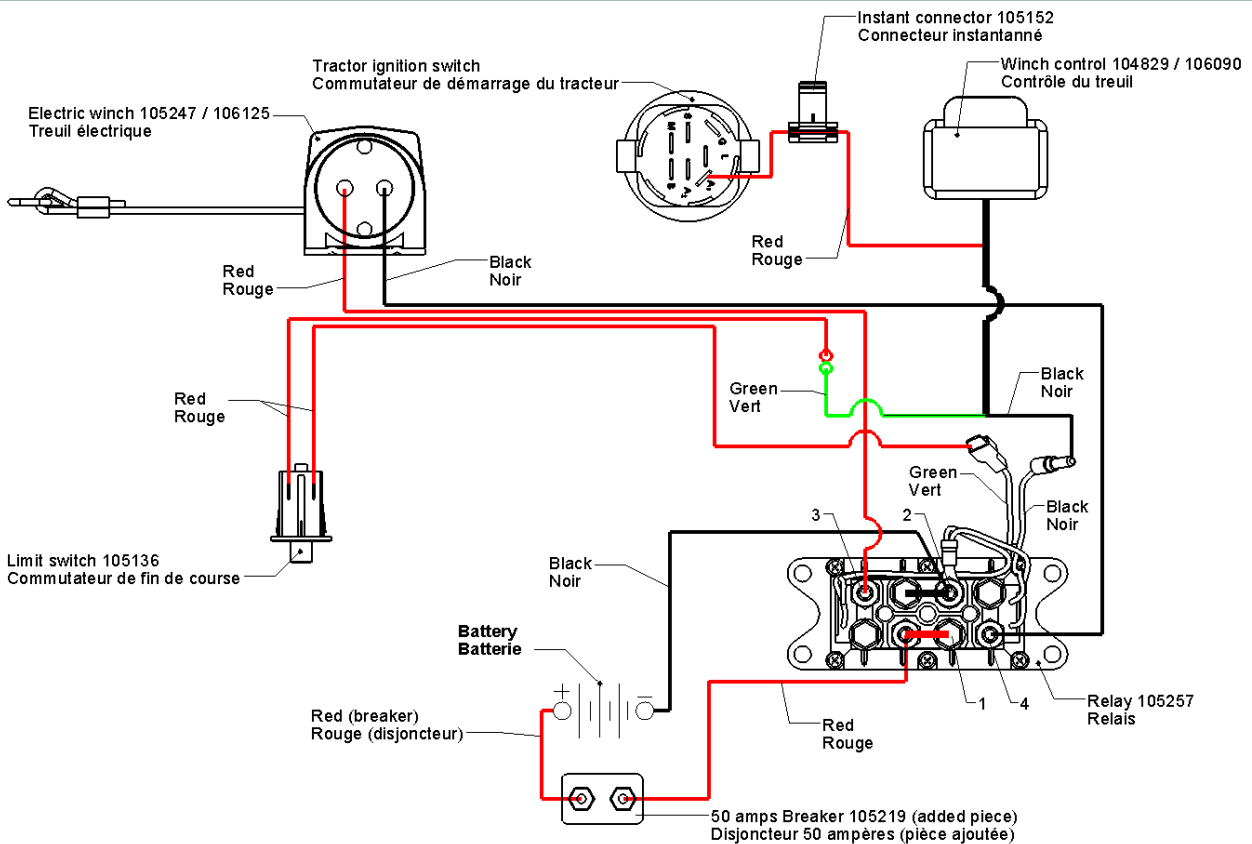

NOMENCLATURE ET LISTE DES PIÈCES / PARTS BREAKDOWN & PART LIST

Sous-châssis XT1 & XT2 #700796

Subframe XT1 & XT2 #700796

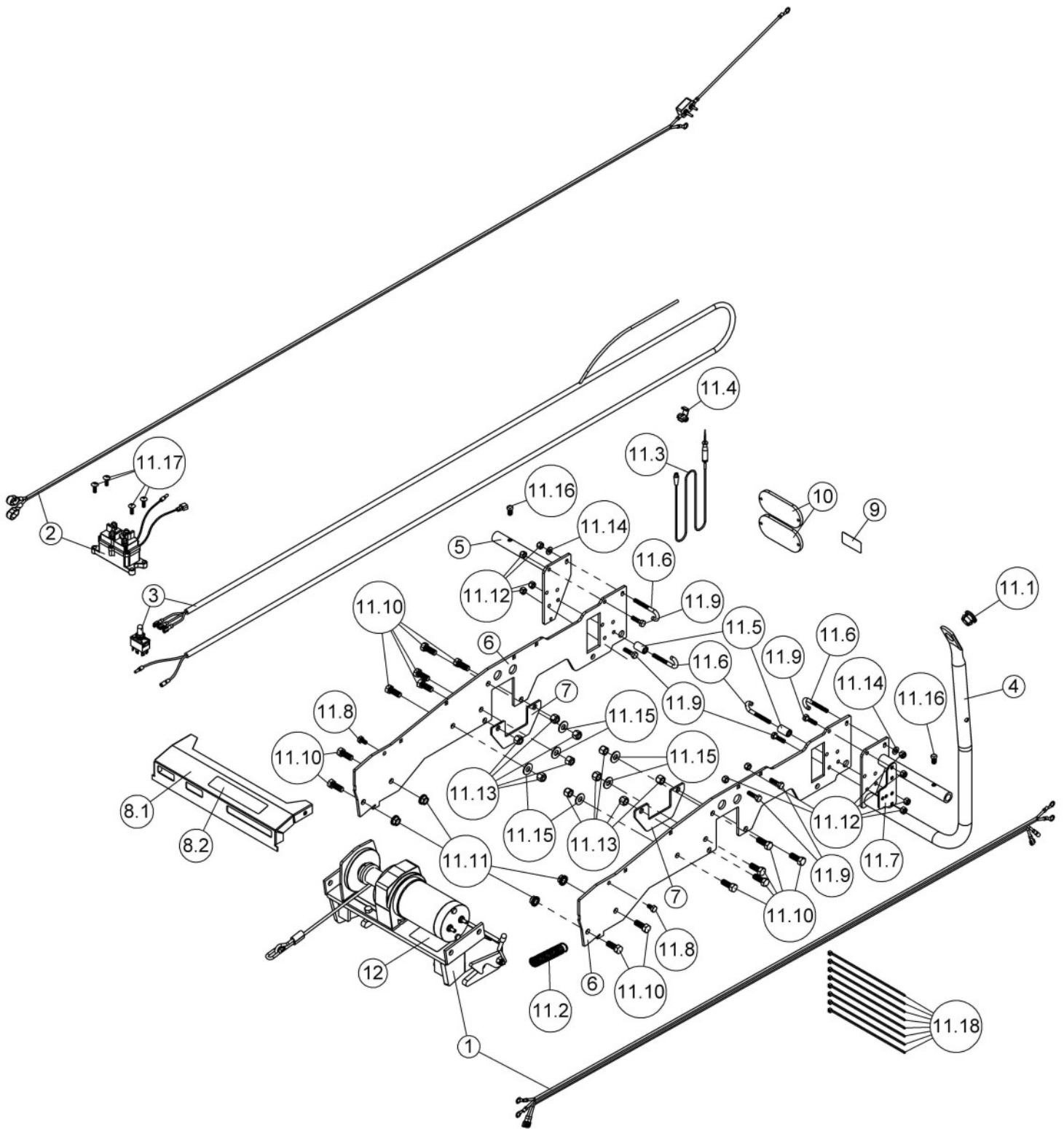

NOMENCLATURE ET LISTE DES PIÈCES / PARTS BREAKDOWN & PART LIST
Sous-châssis XT1 & XT2 #700796
Subframe XT1 & XT2 #700796

REF.	ENGLISH DESCRIPTION	DESCRIPTION FRANÇAISE	QTY.	PART#
1	Winch Assembly	Treuil Assemblé	1	501088
2	Harness assembly	Harnais assemblé	1	501240
3	Winch control wire assembly	Fil du contrôle de treuil assemblé	1	501252
4	Handle support	Support de manivelle	1	108098
5	Cab support	Support de cabine	1	108099
6	Support	Support	2	108100
7	Reinforcement plate	Plaque de renforcement	2	108101
8	Heat Shield with safety decal	Pare-Chaleur avec déc. de sec.	1	107866
8.1	Heat shield	Pare-chaleur	1	104824
8.2	Decal caution hot surfaces	Décalque attention surfaces chaudes	1	105133
9	Lift decal	Décalque de relevage	1	106124
10	Reflector (Pack of 2)	Réflecteur (Ensemble de 2)	1	106108
11	Hardware Bag	Sac de Quincaillerie	1	108103
11.1	Plastic grommet	Oeillet de plastique	1	102063
11.2	Spring	Ressort	1	103566
11.3	Hi/low voltage tester	Testeur de haute/basse tension	1	105151
11.4	Instant connector	Connecteur instantané	1	105152
11.5	Sleeve	Douille	2	108102
11.6	J-bolt	Boulon en J	4	108104
11.7	Oil hose attaching plate	Plaque d'attache tuyau huile	1	108195
11.8	Hex. bolt 1/4" n.c. x 1/2" GR5	Boulon hex. 1/4" n.c. x 1/2" GR5	2	O/L (300NC.5P_1-4x1-2)
11.9	Hex. bolt 1/4" n.c. x 1" GR5	Boulon hex. 1/4" n.c. x 1" GR5	6	O/L (300NC.5P_1-4x1)
11.10	Hex. bolt 3/8" n.c. x 1" GR5	Boulon hex. 3/8" n.c. x 1" GR5	14	O/L (300NC.5P_3-8x1)
11.11	Flange nut 3/8" n.c.	Écrou à bride 3/8" n.c.	4	O/L (334NC.P_3-8)
11.12	Nylon Insert lock Nut 1/4" n.c.	Écrou à garniture de nylon 1/4" n.c.	10	O/L (335NC.P_1-4)
11.13	Nylon Insert lock Nut 3/8" n.c.	Écrou à garniture de nylon 3/8" n.c.	10	O/L (335NC.P_3-8)
11.14	Flat washer 1/4" hole	Rondelle plate 1/4" trou	2	O/L (360.P_1-4T)
11.15	Flat washer 3/8" hole	Rondelle plate 3/8" trou	6	O/L (360.P_3-8T)
11.16	Square head set screw 5/16" x 1/2"	Vis à pression à tête carré 5/16" x 1/2"	2	O/L (392NC.P_5-16x1-2)
11.17	Metal screw T.H. #12" x 3/4"	Vis à métal T.H. #12" x 3/4"	4	O/L (399.P_#12x3-4)
11.18	Tie wrap 8"	Attache de nylon 8"	8	O/L (426-8)
12	Model number	Numéro de modèle	1	REF.

NOMENCLATURE ET LISTE DES PIÈCES / PARTS BREAKDOWN & PART LIST
Méc. d'entraînement Compact XT1 et XT2 #700798
Drive Compact XT1 & XT2 #700798

REF.	ENGLISH DESCRIPTION	DESCRIPTION FRANÇAISE	QTY.	PART#
1	Drive Frame Assembly "Compact"	Châssis d'entraînement Assemblé "Compact"	1	501304
2	Hardware bag	Sac de quincaillerie	1	108094
2.1	Belt guide	Guide-courroie	1	108078
2.2	Belt guide	Guide-courroie	1	108079
2.3	Hex. bolt 3/8" n.c. x 1" GR5	Boulon hex. 3/8" n.c. x 1" GR5	2	O/L (300NC.5P_3-8x1)
2.4	Nylon Insert lock Nut 3/8" n.c.	Écrou à garniture de nylon 3/8" n.c.	2	O/L (335NC.P_3-8)
2.5	Flat washer 3/8" hole	Rondelle plate 3/8" trou	6	O/L (360.P_3-8T)
2.6	Spring hook	Crochet de ressort	1	108092
3	V-Belt , B-118	Courroie en V , B-118	1	104044

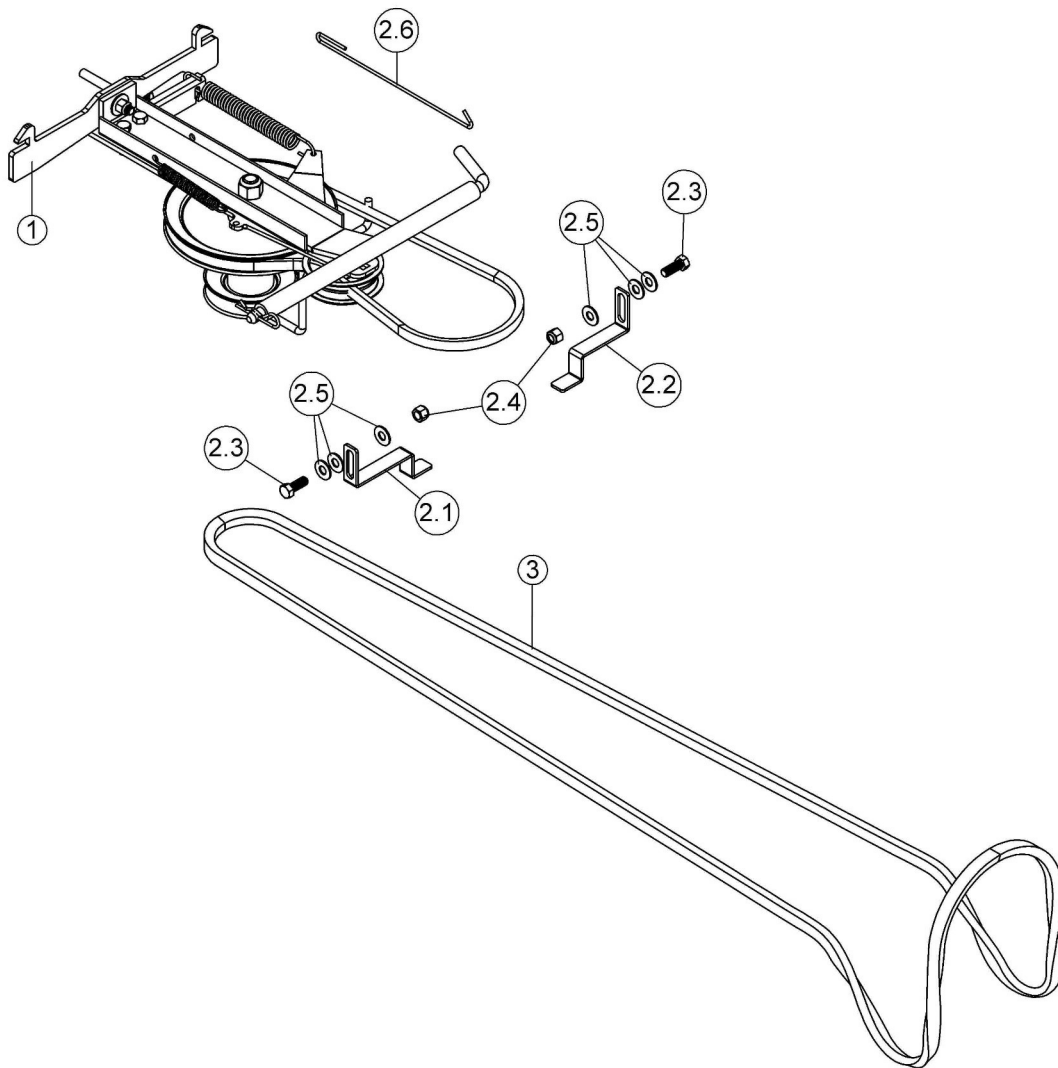

O/L = Obtain Locally / Obtenir localement

NOMENCLATURE ET LISTE DES PIÈCES / PARTS BREAKDOWN & PART LIST
Mécanisme d'entraînement Nordet XT1 et XT2 #700797
Drive Northeast XT1 & XT2 #700797

REF.	ENGLISH DESCRIPTION	DESCRIPTION FRANÇAISE	QTY.	PART#
1	Drive Frame Assembly "Northeast"	Châssis d'entraînement Assemblé "Nordet"	1	501303
2	Hardware bag	Sac de quincaillerie	1	108094
2.1	Belt guide	Guide-courroie	1	108078
2.2	Belt guide	Guide-courroie	1	108079
2.3	Hex. bolt 3/8" n.c. x 1" GR5	Boulon hex. 3/8" n.c. x 1" GR5	2	O/L (300NC.5P_3-8x1)
2.4	Nylon Insert lock Nut 3/8" n.c.	Écrou à garniture de nylon 3/8" n.c.	2	O/L (335NC.P_3-8)
2.5	Flat washer 3/8" hole	Rondelle plate 3/8" trou	6	O/L (360.P_3-8T)
2.6	Spring hook	Crochet de ressort	1	108092
3	V-Belt , B-124	Courroie en V , B-124	1	102484

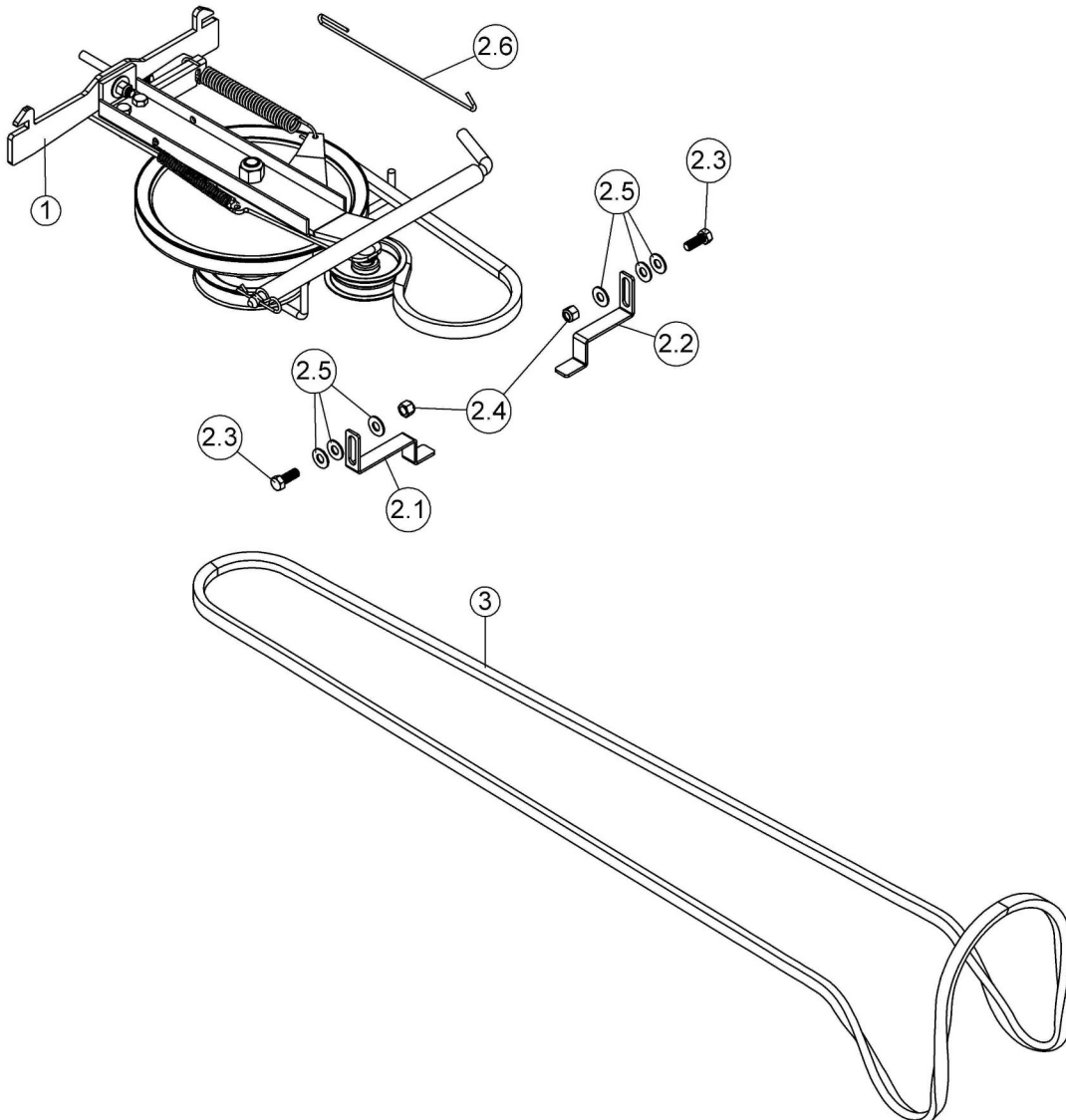

O/L = Obtain Locally / Obtenir localement

NOMENCLATURE ET LISTE DES PIÈCES / PARTS BREAKDOWN & PART LIST

Treuil Assemblé #501088

Winch Assembly #501088

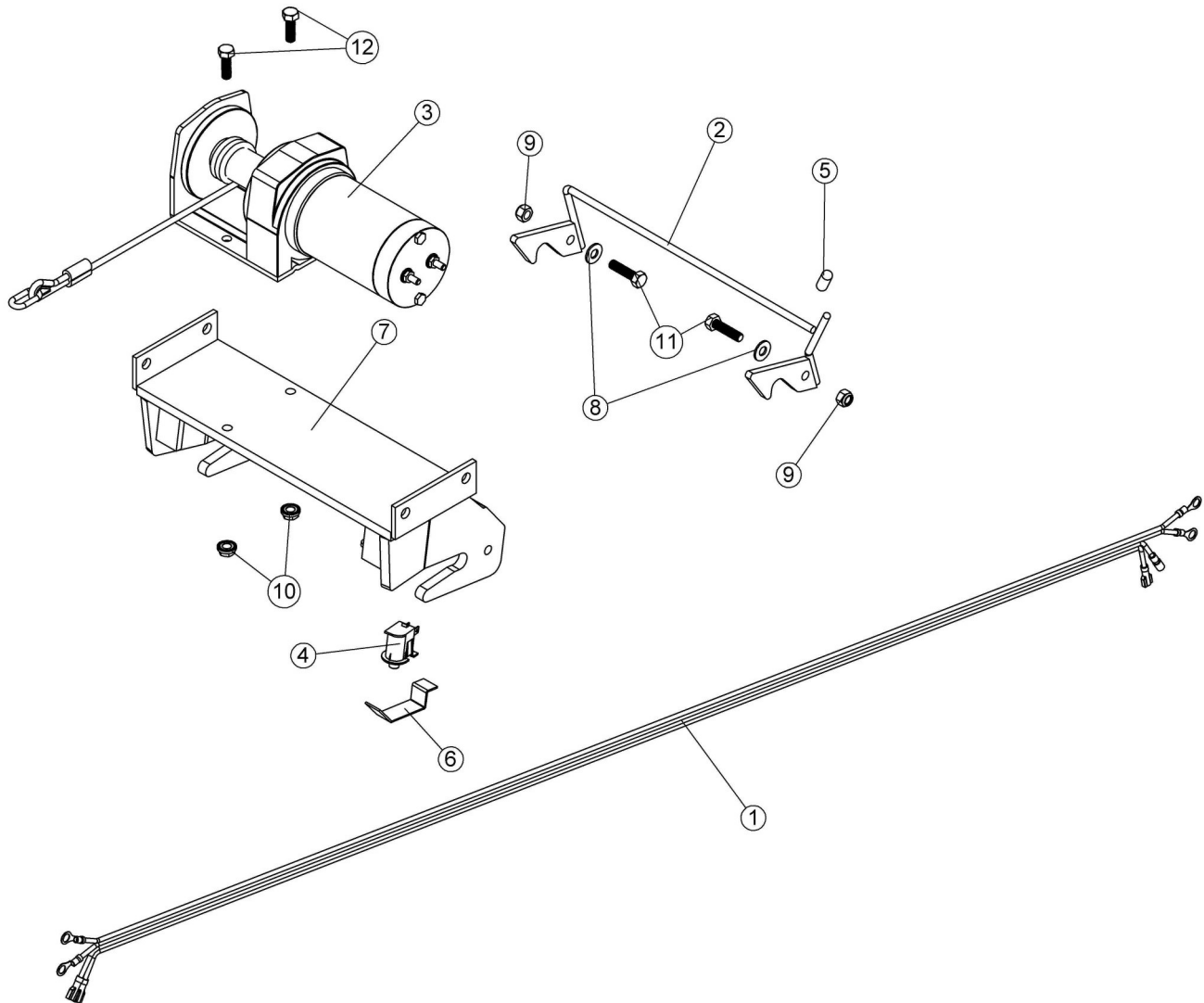

O/L = Obtain Locally / Obtenir localement

NOMENCLATURE ET LISTE DES PIÈCES / PARTS BREAKDOWN & PART LIST
Treuil Assemblé #501088
Winch Assembly #501088

REF.	ENGLISH DESCRIPTION	DESCRIPTION FRANÇAISE	QTY.	PART#
1	Wire assembly	Fil assemblé	1	105256
2	Latch	Loquet	1	104818
3	Winch assembly	Treuil assemblé	1	106125
4	Limit switch	Commutateur de fin de course	1	105136
5	Handgrip	Poignée	1	104825
6	Push plate	Plaque de poussée	1	105150
7	Female hitch	Attache femelle	1	104817
8	Flat washer 5/16" hole	Rondelle plate 5/16" trou	2	O/L (360.P_5-16T)
9	Nylon Insert lock Nut 5/16" n.c. GR5	Écrou à garniture de nylon 5/16" n.c. GR5	2	O/L (335NC.P_5-16)
10	Flange nut 5/16" n.c.	Écrou à bride 5/16" n.c.	2	O/L (334NC.P_5-16)
11	Hex. bolt 5/16" n.c. x 1 1/4" GR5	Boulon hex. 5/16" n.c. x 1 1/4" GR5	2	O/L (300NC.5P_5-16x1-1-4)
12	Hex. bolt 5/16" n.c. x 1" GR5	Boulon hex. 5/16" n.c. x 1" GR5	2	O/L (300NC.5P_5-16x1)

O/L = Obtain Locally / Obtenir localement

NOMENCLATURE ET LISTE DES PIÈCES / PARTS BREAKDOWN & PART LIST
Harnais assemblé #501240
Harness assembly #501240

REF.	ENGLISH DESCRIPTION	DESCRIPTION FRANÇAISE	QTY.	PART#
1	Wire assembly	Fil assemblé	1	104831
2	Relay	Relais	1	105257

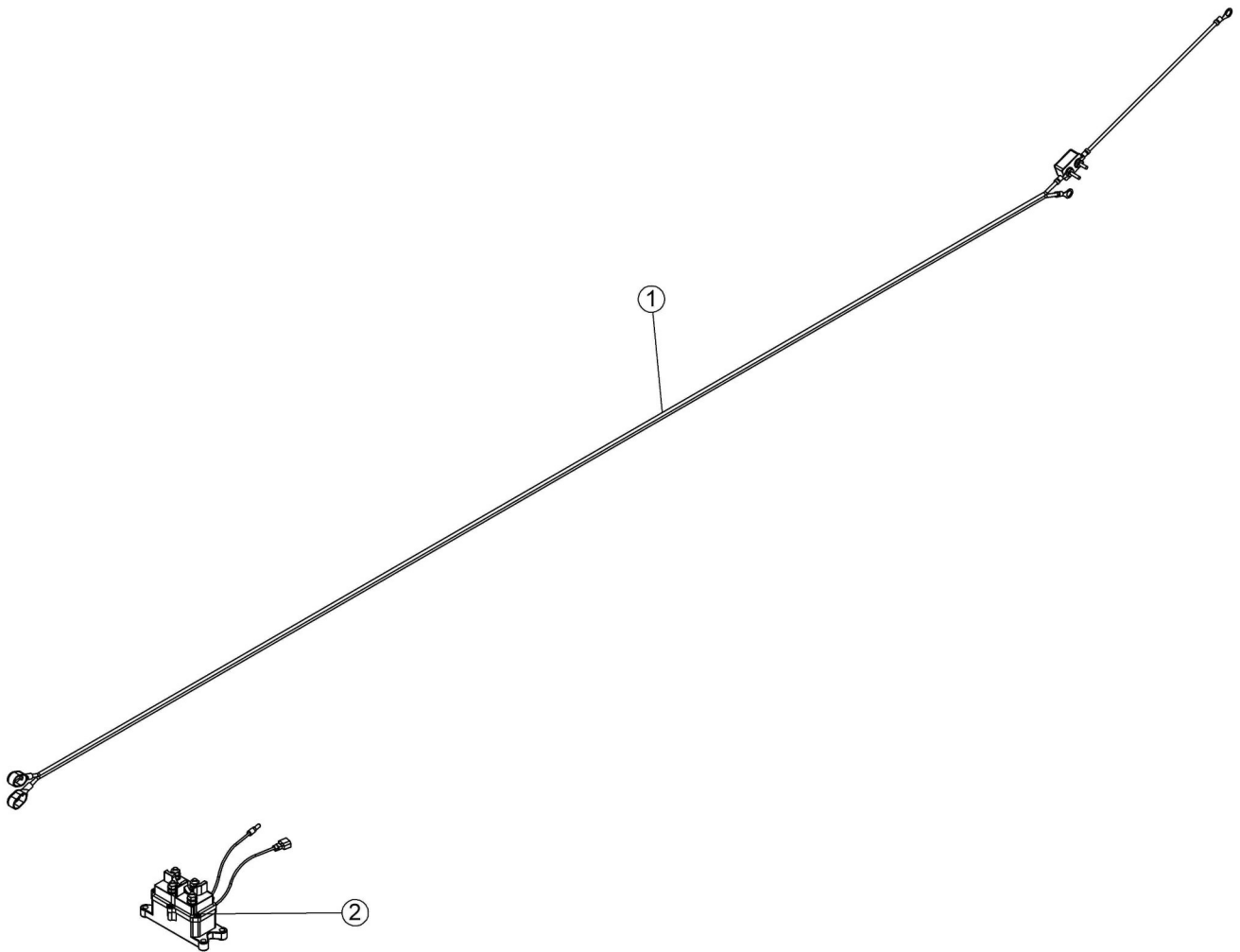

O/L = Obtain Locally / Obtenir localement

NOMENCLATURE ET LISTE DES PIÈCES / PARTS BREAKDOWN & PART LIST
Fil du contrôle de treuil assemblé #501252
Winch control wire assembly #501252

REF.	ENGLISH DESCRIPTION	DESCRIPTION FRANÇAISE	QTY.	PART#
1	Winch control wire	Fil du contrôle du treuil	1	106103
2	Winch control switch	Commutateur de contrôle du treuil	1	106090

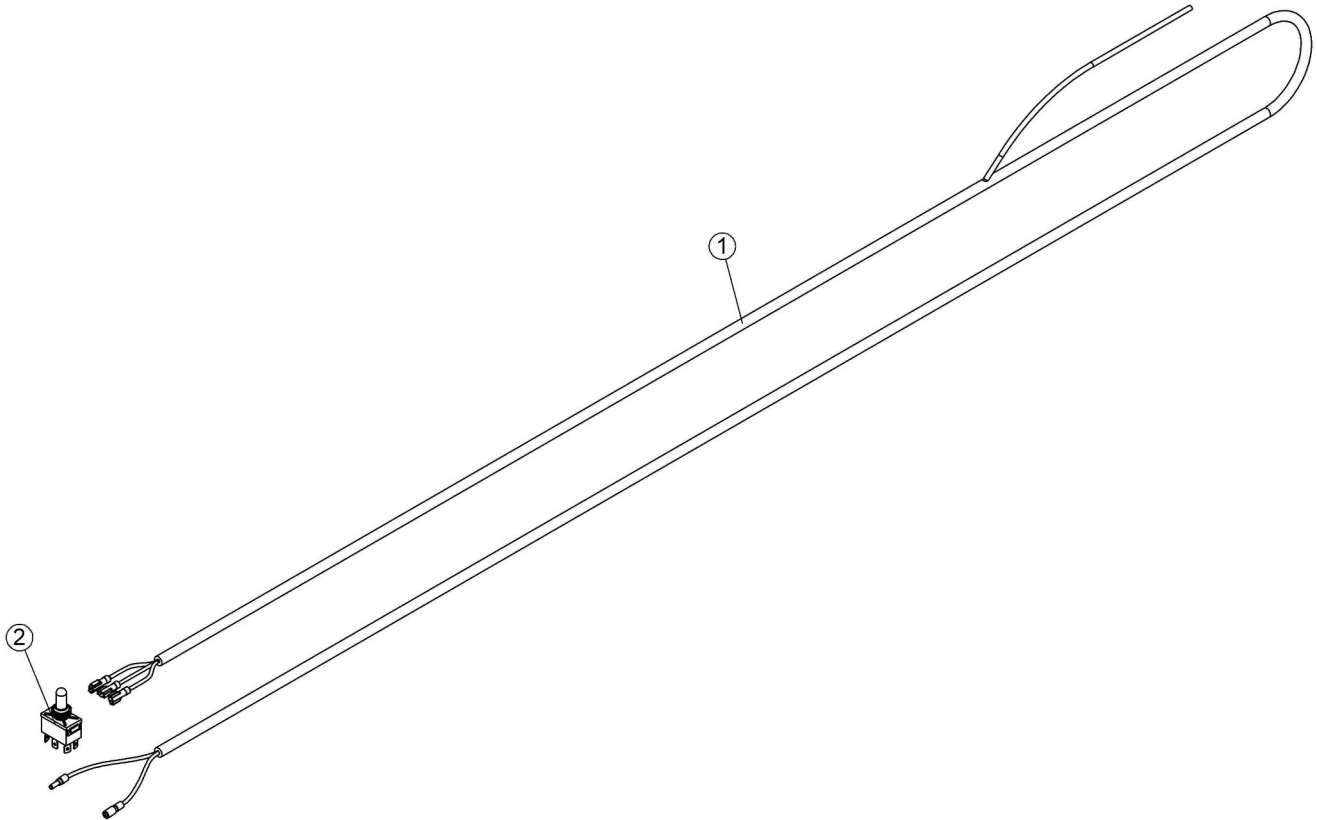

O/L = Obtain Locally / Obtenir localement

NOMENCLATURE ET LISTE DES PIÈCES / PARTS BREAKDOWN & PART LIST
Châssis d'entrainement Assemblé "Nordet" #501303
Drive Frame Assembly "Northeast" #501303

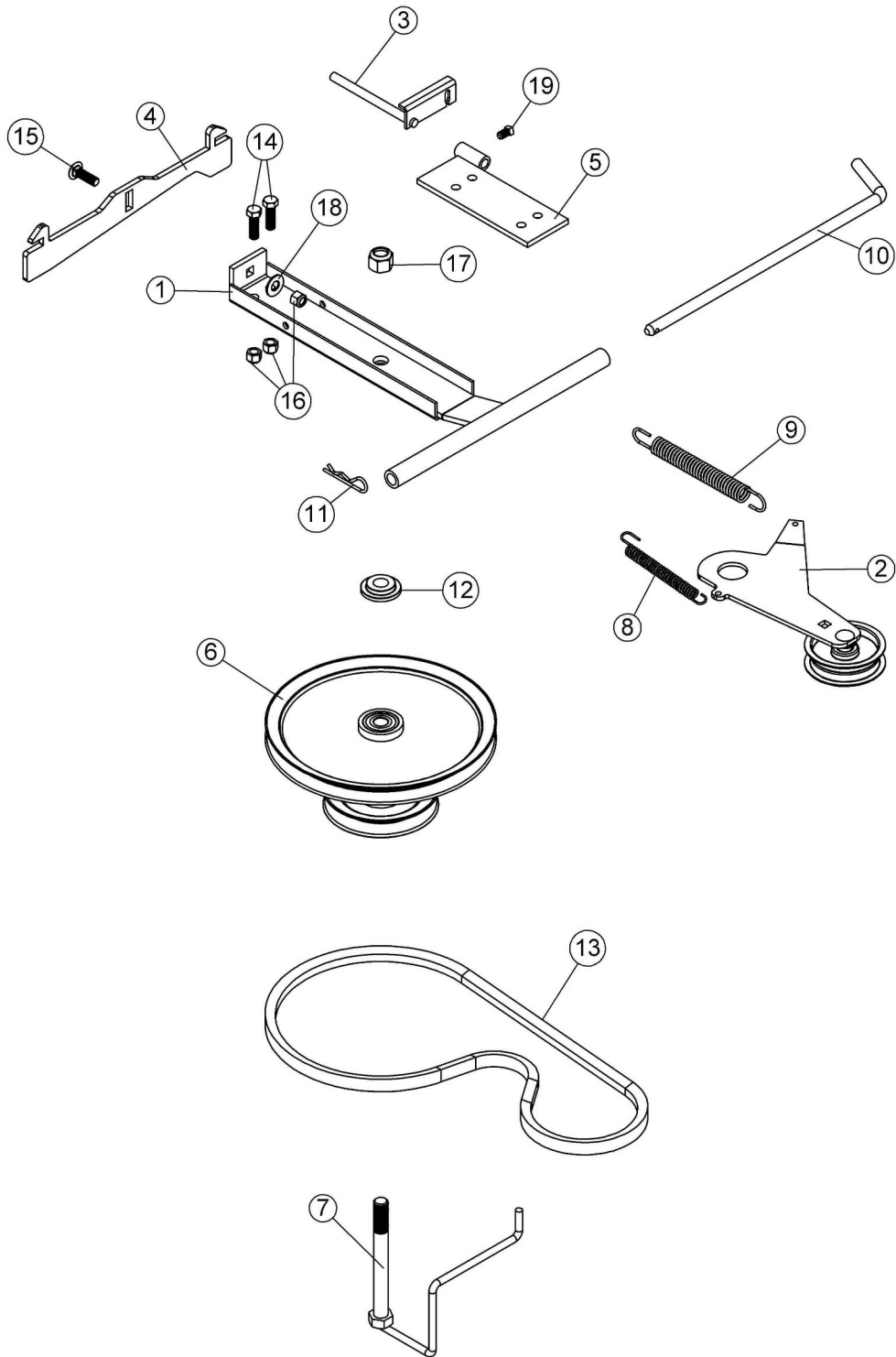

O/L = Obtain Locally / Obtenir localement

NOMENCLATURE ET LISTE DES PIÈCES / PARTS BREAKDOWN & PART LIST
Châssis d'entraînement Assemblé "Nordet" #501303
Drive Frame Assembly "Northeast" #501303

REF.	ENGLISH DESCRIPTION	DESCRIPTION FRANÇAISE	QTY.	PART#
1	Drive frame	Châssis d'entraînement	1	108076
2	Pulley assembly	Poulie assemblée	1	501089
3	Adjustment rod	Tige d'ajustement	1	104841
4	Support	Support	1	108075
5	Adjustment rod support	Support de tige d'ajustement	1	108077
6	Double pulley inc. 102736 & 103035	Poulie double inc. 102736 & 103035	1	103040
7	Belt guide	Guide-courroie	1	104043
8	Spring 1/2"	Ressort 1/2"	1	102003
9	Spring	Ressort	1	102304
10	Pin	Goupille	1	102754
11	Hair pin 3mm	Goupille à ressort 3mm	1	102617
12	Flange washer	Rondelle à bride	1	102969
13	V-Belt , A-48	Courroie en V , A-48	1	103121
14	Hex. bolt 3/8" n.c. x 1 1/4" GR5	Boulon hex. 3/8" n.c. x 1 1/4" GR5	2	O/L (300NC.5P_3-8x1-1-4)
15	Carriage bolt 3/8" n.c. x 1 1/4 " GR5	Boulon à carrosserie 3/8" n.c. x 1 1/4 " GR5	1	O/L (320NC.5P_3-8x1-1-4)
16	Nylon Insert lock Nut 3/8" n.c.	Écrou à garniture de nylon 3/8" n.c.	3	O/L (335NC.P_3-8)
17	Nylon Insert lock Nut 5/8" n.c.	Écrou à garniture de nylon 5/8" n.c.	1	O/L (335NC.P_5-8)
18	Flat washer 7/16" hole	Rondelle plate 7/16" trou	1	O/L (360.P_7-16T)
19	Square head set screw 5/16" x 1/2"	Vis à pression à tête carré 5/16" x 1/2"	1	O/L (392NC.P_5-16x1-2)

O/L = Obtain Locally / Obtenir localement

NOMENCLATURE ET LISTE DES PIÈCES / PARTS BREAKDOWN & PART LIST
Châssis d'entraînement Assemblé "Compact" #501304
Drive Frame Assembly "Compact" #501304

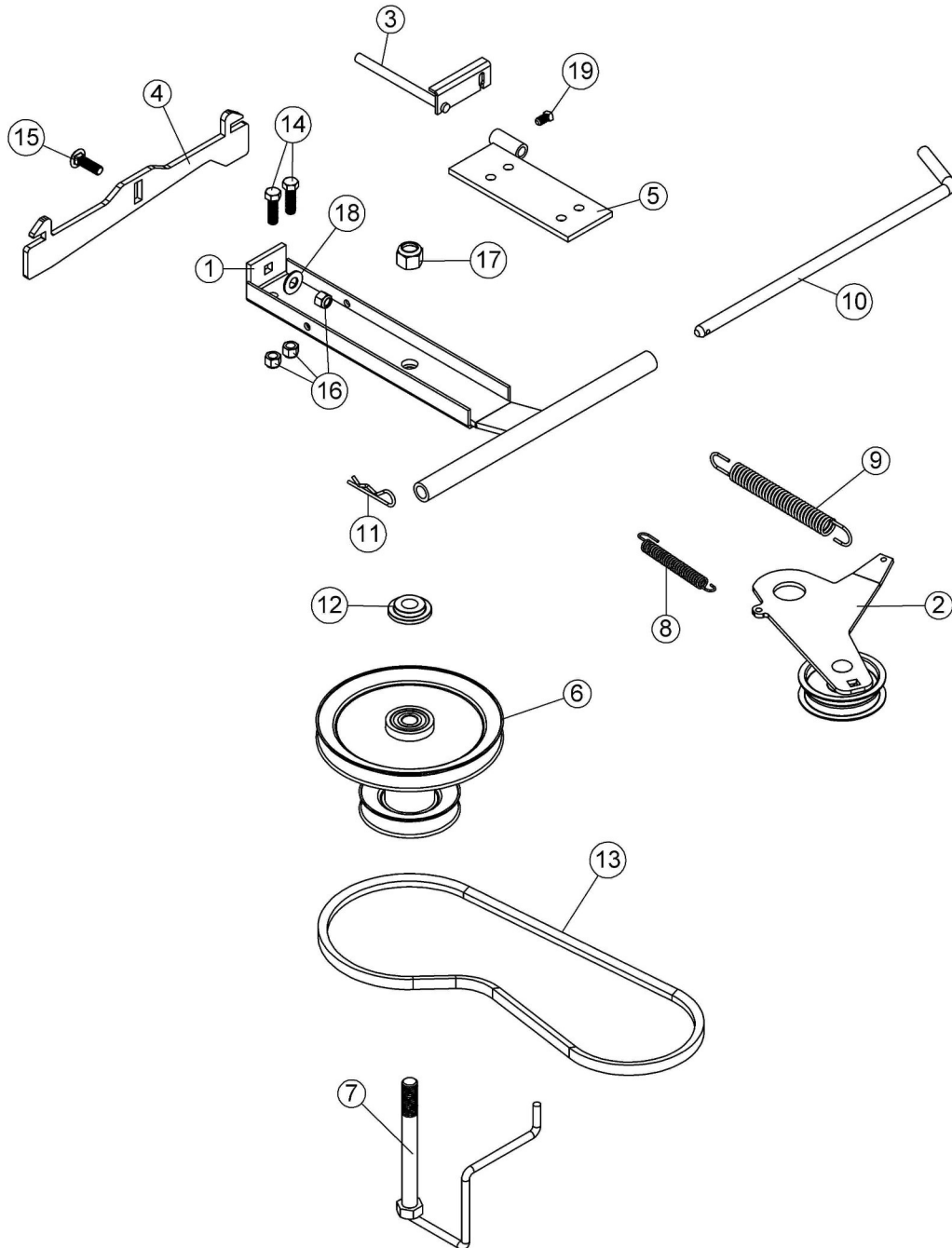

O/L = Obtain Locally / Obtenir localement

NOMENCLATURE ET LISTE DES PIÈCES / PARTS BREAKDOWN & PART LIST

Châssis d'entraînement Assemblé "Compact" #501304

Drive Frame Assembly "Compact" #501304

REF.	ENGLISH DESCRIPTION	DESCRIPTION FRANÇAISE	QTY.	PART#
1	Drive frame	Châssis d'entraînement	1	108076
2	Pulley assembly	Poulie assemblée	1	501246
3	Adjustment rod	Tige d'ajustement	1	104841
4	Support	Support	1	108075
5	Adjustment rod support	Support de tige d'ajustement	1	108077
6	Double pulley inc. 102736 & 108091	Poulie double inc. 102736 & 108091	1	108090
7	Belt guide	Guide-courroie	1	108093
8	Spring 1/2"	Ressort 1/2"	1	102003
9	Spring	Ressort	1	102304
10	Pin	Goupille	1	102754
11	Hair pin 3mm	Goupille à ressort 3mm	1	102617
12	Flange washer	Rondelle à bride	1	102969
13	V-Belt , A-44	Courroie en V , A-44	1	103615
14	Hex. bolt 3/8" n.c. x 1 1/4" GR5	Boulon hex. 3/8" n.c. x 1 1/4" GR5	2	O/L (300NC.5P_3-8x1-1-4)
15	Carriage bolt 3/8" n.c. x 1 1/4 " GR5	Boulon à carrosserie 3/8" n.c. x 1 1/4 " GR5	1	O/L (320NC.5P_3-8x1-1-4)
16	Nylon Insert lock Nut 3/8" n.c.	Écrou à garniture de nylon 3/8" n.c.	3	O/L (335NC.P_3-8)
17	Nylon Insert lock Nut 5/8" n.c.	Écrou à garniture de nylon 5/8" n.c.	1	O/L (335NC.P_5-8)
18	Flat washer 7/16" hole	Rondelle plate 7/16" trou	1	O/L (360.P_7-16T)
19	Square head set screw 5/16" x 1/2"	Vis à pression à tête carré 5/16" x 1/2"	1	O/L (392NC.P_5-16x1-2)

O/L = Obtain Locally / Obtenir localement

TORQUE SPECIFICATION TABLE

GENERAL TORQUE SPECIFICATION TABLE USE THE FOLLOWING TORQUES WHEN SPECIAL TORQUES ARE NOT GIVEN

NOTE: These values apply to fasteners as received from supplier, dry or when lubricated with normal oil. They do not apply if special graphited or moly disulphide greases or other extreme pressure lubricants are used. This applies to both UNF and UNC threads.

* Thick nuts must be used with grade 8 bolts

SEE Grade No.		2				5				8 *			
BOLT HEAD IDENTIFICATION MARKS AS PER GRADE NOTE MANUFACTURING MARKS WILL VARY		TORQUE				TORQUE				TORQUE			
BOLT SIZE		FOOT POUNDS		NEW TON-METERS		FOOT POUNDS		NEW TON-METERS		FOOT POUNDS		NEW TON-METERS	
Inches	Millimetre	Min.	Max.	Min.	Max.	Min.	Max.	Min.	Max.	Min.	Max.	Min.	Max.
1/4"	6.35	5	6	6.8	8.13	9	11	12.2	14.9	12	15	16.3	30.3
5/16"	7.94	10	12	13.6	16.3	17	20.5	23.1	27.8	24	29	32.5	39.3
3/8"	9.53	20	23	27.1	31.2	35	42	47.5	57	45	54	61	73.2
7/16"	11.11	30	35	40.7	47.4	54	64	73.2	86.8	70	84	94.9	113.9
1/2"	12.7	45	52	61	70.5	80	96	108.5	130.2	110	132	149.2	179
9/16"	14.29	65	75	88.1	101.6	110	132	149.2	179	160	192	217	260.4
5/8"	15.88	95	105	128.7	142.3	150	180	203.4	244.1	220	264	298.3	358
3/4"	19.05	150	185	203.3	250.7	270	324	366.1	439.3	380	456	515.3	618.3
7/8"	22.23	160	200	216.8	271	400	480	542.4	650.9	600	720	813.6	976.3
1"	25.4	250	300	338.8	406.5	580	696	786.5	943.8	900	1080	1220.4	1464.5

METRIC BOLT TORQUE SPECIFICATIONS							
		COARSE THREAD			FINE THREAD		
Size Screw	Grade No.	Pitch (mm)	Foot Pounds	Newton-Meters	Pitch (mm)	Foot Pounds	Newton-Meters
M6	4T	1.00	3.6 - 5.8	4.9 - 7.9	-	-	-
	7T		5.8 - 9.4	7.9 - 12.7		-	-
	8T		7.2 - 10	9.8 - 13.6		-	-
M8	4T	1.25	7.2 - 14	9.8 - 19	1.00	12 - 17	16.3 - 23
	7T		17 - 22	23 - 29.8		19 - 27	25.7 - 36.6
	8T		20 - 26	27.1 - 35.2		22 - 31	29.8 - 42
M10	4T	1.50	20 - 25	27.1 - 33.9	1.25	20 - 29	27.1 - 39.3
	7T		34 - 40	46.1 - 54.2		35 - 47	47.4 - 63.7
	8T		38 - 46	51.5 - 62.3		40 - 52	54.2 - 70.5
M12	4T	1.75	28 - 34	37.9 - 46.1	1.25	31 - 41	42 - 55.6
	7T		51 - 59	69.1 - 79.9		56 - 68	75.9 - 92.1
	8T		57 - 66	77.2 - 89.4		62 - 75	84 - 101.6
M14	4T	2.00	49 - 56	66.4 - 75.9	1.50	52 - 64	70.5 - 86.7
	7T		81 - 93	109.8 - 126		90 - 106	122 - 143.6
	8T		96 - 109	130.1 - 147.7		107 - 124	145 - 168
M16	4T	2.00	67 - 77	90.8 - 104.3	1.50	69 - 83	93.5 - 112.5
	7T		116 - 130	157.2 - 176.2		120 - 138	162.6 - 187
	8T		129 - 145	174.8 - 196.5		140 - 158	189.7 - 214.1
M18	4T	2.00	88 - 100	119.2 - 136	1.50	100 - 117	136 - 158.5
	7T		150 - 168	203.3 - 227.6		177 - 199	239.8 - 269.6
	8T		175 - 194	237.1 - 262.9		202 - 231	273.7 - 313
M20	4T	2.50	108 - 130	146.3 - 176.2	1.50	132 - 150	178.9 - 203.3
	7T		186 - 205	252 - 277.8		206 - 242	279.1 - 327.9
	8T		213 - 249	288.6 - 337.4		246 - 289	333.3 - 391.6

ATTACHMENTS

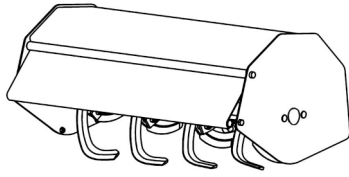

ROTARY TILLER #700312

Mounts to the rear of lawn, yard & garden tractors 14 to 25 HP. Comes complete with drive & manual lift mechanisms & mounting hardware

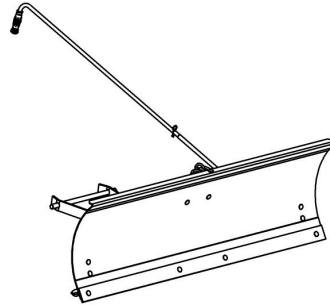

BLADE #700463

Mounts on the same subframe as the snowblower & rotary broom.

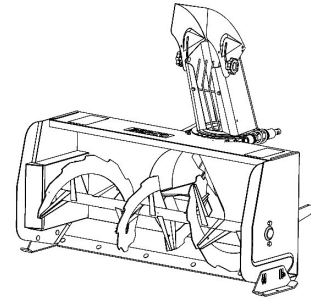

SOUFFLEUSE
700465 40"
700474 44"
700478 48"

Mounts on the same subframe as the blade & rotary broom.

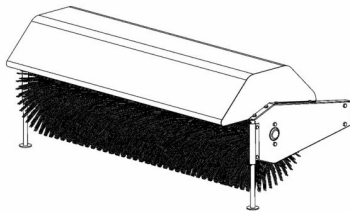

ROTARY BROOM
#700380 with nylon brush
#700381 with polypropylene brush.

Fits on same subframe as snowblower & utility blade. Requires an adaptor.

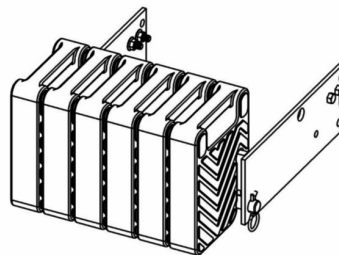

COUNTERWIEGHT

According to tractor model

Required for safety and traction. Counterbalances weight of attachment.

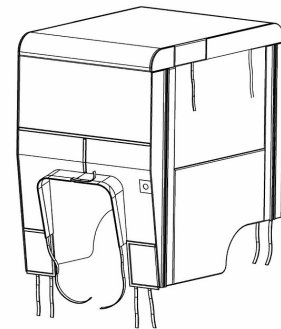

TRACTOR WINTER CAB
#700271 34"
#700423 40"

Universal type fits on a wide variety of lawn and garden tractors.

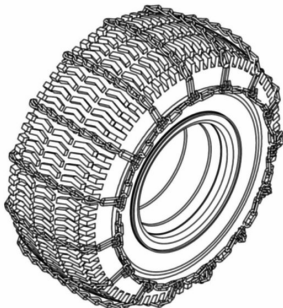

TIRE CHAINS

Two link spacing. Required for traction and safety.
Pkg. of 2



**WHEN PERFORMANCE
& DEPENDABILITY
ARE NON NEGOTIABLE !**

**Bercomac Limitée
92, Fortin North, Adstock, Quebec, Canada, G0N 1S0**

WWW.BERCOMAC.COM

PRINTED IN CANADA

(ORIGINAL NOTICE)