



OWNER'S MANUAL
MODEL NUMBER

700271-1 Tractor Winter Cab
700313-1 Tractor Screen Cab



BERCO
Universal Mounting Tractor Cabs

* ASSEMBLY

* REPAIR PARTS

CAUTION:

**READ & FOLLOW ALL SAFETY RULES & INSTRUCTIONS
BEFORE OPERATING YOUR EQUIPMENT**



LIMITED WARRANTY

Conditions and Products Covered:

BERCOMAC guarantees any part of the product or accessory manufactured by BERCOMAC and found in the reasonable judgment of BERCOMAC to be defective in material and or workmanship will be repaired or replaced by an authorized dealer without charge up to our maximum labor rates and pre-established times. For replacement parts only standard ground freight services are covered. This warranty extends to the original retail purchaser only and is not transferable to any subsequent purchasers.

Warranty Period

(from date of the original retail purchase):

- Residential use: 1 year
- Commercial or rental use: 90 days

Exceptions Noted Below; the following items are guaranteed by the original manufacturer and have their own warranty, conditions and limited time:

- Tire Chains: 90 days
- Engines (installed in factory on BERCO equipment): 2 years
- Engines (sold separately): Validate with the dealer.
Please refer to the engine manufacturer's warranty statement included with the unit. BERCOMAC is not authorized to handle warranty adjustments on engines.

Items and Conditions NOT Covered:

This warranty does not cover the following:

- Pick-up or delivery charges or in-home services fees.
- Any damage or deterioration of the unit, parts and or finish of these due to normal use, wear and tear, or exposure.
- Cost of regular use or maintenance service or parts, such as gas, oil, lubricants, tune-up parts, and adjustments.
- Any part or accessory which has been altered, modified, misused, neglected, accidentally damaged or not properly installed, maintained, stored or repaired not in accordance with the instructions in the owner's manual.
- Repair due to normal wear and or any wear items such as shear pins, bolts, belts, etc.
- Expedited freight fee services for replacement parts.
- Shear bolts and shear pins are to be considered as a preventive measure not as an assured protection, any damages resulting from the lack of shear bolts breakage are not covered.

NOTE: All warranty work must be performed by an authorized dealer using original (manufacturer) replacement parts.

NOTE: Bercomac reserves the right to change or improve the design of any part or accessory without assuming any obligation to modify any product previously manufactured.

Instructions for Obtaining Warranty Services:

Contact dealer where equipment was purchased or any other BERCOMAC service dealer to arrange service at their dealership. To locate a dealer convenient to you, access our website at www.bercomac.com. Don't forget to bring the product and your proof of purchase (sales receipt) to the BERCOMAC dealer.

Owner's Responsibilities:

BERCOMAC's defective equipment or part must be returned to an authorized dealer within the warranty period for repairs. In the event that defective merchandise must be returned to manufacturer for repairs, freight fees are prepaid and a written authorization from BERCOMAC must be obtained by dealer prior to the shipment. This warranty extends only to equipment operated under normal conditions. To validate a warranty claim, it is the user's responsibility to maintain and service the unit as specified in the owner's manual or to have the unit serviced at their dealer at their expense.

General Conditions:

The sole liability of BERCOMAC with respect to this warranty shall be strictly and exclusively repair and replacement as mentioned herein. BERCOMAC shall not have any liability for any other costs, loss or damage, including but not limited to, any incidental or consequential loss or damage.

In particular, without being limited to, BERCOMAC shall have no liability or responsibility for:

- Travel time, overtime, after hours time or other extraordinary repair charges or relating to repairs and or replacements outside of normal business hours.
- Rental of like or similar replacement equipment during the period of any, repair or replacement work.
- Any communicating or travel charges.
- Loss or damage to person or property other than that covered by the terms of this warranty.
- Any claims for lost revenue, lost profit or any similar costs as a result of damage or repair.
- Attorney's fees.

BERCOMAC's responsibility in respect to claims is limited to making the required repairs or replacement without charge up to our maximum labor rates and pre-established times and no claim of breach of warranty shall be cause for cancellation or rescission of the contract of sale of any product or accessory.

This warranty gives you specific legal rights. You may also have other rights, which vary from state to state.

TABLE OF CONTENTS

PAGE

INTRODUCTION	2
SAFETY PRECAUTIONS	3
ASSEMBLY	
Installation Information	4
Tools Required	4
Step 1: Frame Assembly—Roof	4
Step 2: Tow Hitch Support Installation	5
Step 3: Front Attaching Plates Installation	6
Step 4: Frame Assembly	7
Step 5: Canvas Installation	7
MAINTENANCE	8
PARTS BREAKDOWN AND LISTS	
Cab	9

INTRODUCTION

TO THE PURCHASER

This new accessory was carefully designed to give years of dependable service. This manual has been provided to assist in the safe operation and servicing of your attachment.

NOTE: All photographs and illustrations in the manual may not necessarily depict the actual models or attachment, but are intended for reference only and are based on the latest product information available at the time of publication.

Familiarize yourself fully with the safety recommendations and operating procedures before putting the machine to use. Carefully read, understand and follow these recommendations and insist that they be followed by those who will use this attachment.



THIS SAFETY ALERT SYMBOL IDENTIFIES AN IMPORTANT SAFETY MESSAGE IN THIS MANUAL THAT HELPS YOU AND OTHERS AVOID PERSONAL INJURY OR EVEN DEATH. DANGER, WARNING, AND CAUTION ARE SIGNAL WORDS USED TO IDENTIFY THE LEVEL OF HAZARD. HOWEVER, REGARDLESS OF THE HAZARD, BE EXTREMELY CAREFUL.

DANGER: Signals an extreme hazard that will cause serious injury or death if recommended precautions are not followed.

WARNING: Signals a hazard that may cause serious injury or death if the recommended precautions are not followed.

CAUTION: Signals a hazard that may cause minor or moderate injury if the recommended precautions are not followed.

Record your attachment serial number and purchase date in the section reserved below (there is no serial number on the subframe). Your dealer requires this information to give you prompt, efficient service when ordering replacement parts. Use only genuine parts when replacements are required.

If warranty repairs are required please present this registration booklet and original sales invoice to your selling dealer for warranty service.

**This manual should be kept for future reference.
Please check if you have received all the parts for your kit with the list of the bag and the list of the box.**

SERIAL NUMBER : (IF APPLICABLE)	
MODEL NUMBER:	
PURCHASE DATE :	

SAFETY PRECAUTIONS

Careful operation is your best insurance against an accident. Read this section carefully before operating the tractor and attachment. All operators, no matter how experienced they may be, should read this and other manuals related to the tractor and attachments before operating. It is the owner's legal obligation to instruct all operators in safe operation.

WHENEVER YOU SEE THIS SYMBOL



IT MEANS:

WARNING!

BECOME ALERT !

YOUR SAFETY IS INVOLVED!



WARNING



TO AVOID PERSONAL INJURY:

Make sure the tractor's exhaust is in good condition and not oriented towards the cab.

EXHAUST FUMES SHOULD NEVER ENTER THE CAB, THEY CONTAIN CARBON MONOXIDE GAS

WHICH IS:

***ODOURLESS**

***COLORLESS**

***DEADLY**

NEVER BLOCK THE AIR VENTS



WARNING



**READ AND FOLLOW ALL SAFETY PRECAUTIONS AND INSTRUCTIONS IN THE OWNER'S MANUAL
FOR BOTH THE TRACTOR AND ATTACHMENT**



WARNING



TO AVOID PERSONAL INJURY:

Visibility must be clear at all times. Keep the windows clear. If needed, clean windows using a soft brush or cloth.

ASSEMBLY

INSTALLATION INFORMATION:

If this cab is being installed on a tractor which already is equipped with a Berco attachment, the subframe (certain but not necessarily all models of subframes) have existing attaching points welded to the mounting supports.

If not, to install this cab onto the tractor you must drill two 9/32" holes in each footrest.

NOTE: The bolts installed on the footrests may be hidden under the rubber pads of the footrests.

IMPORTANT: There is a potential risk of the paint wearing off from the hood or the decal coming off due to cab rubbing against it. To lessen this potential damage, a soft cloth may be inserted between the cab and hood. Wiping down the hood after each use will also help.

NOTE: (for the winter cab) The windows are made of top quality cold resistant, clear flexible plastic. Under extreme cold conditions, all plastics become fragile. Never hit or scrape windows, this could damage them. These damages, under these conditions, are not covered by the manufacturer's warranty.

STEP 1

FRAME ASSEMBLY—ROOF:

Assemble the top portion of the frame by attaching the link tubes (fig.1, item 1) to the side tubes (item 2) with four #10 x 1" machine screws. Attach the reinforcement tube (item 3) (angled portion facing upwards) directly in the middle. Secure loosely all the #10 x 1" machine screws (item 4) (screw heads on top) and nylon insert lock nuts. Place the assembly on a level surface to ensure that the structure is level.

Tighten all the screws firmly.

TOOLS REQUIRED:

1-Drill
1-9/32" (0.281") bit
1-Philips screwdriver
1-3/8" wrench
1-7/16" wrench
1-3/4" wrench
1-3/4" Wescott wrench
1-5/32" Allen key

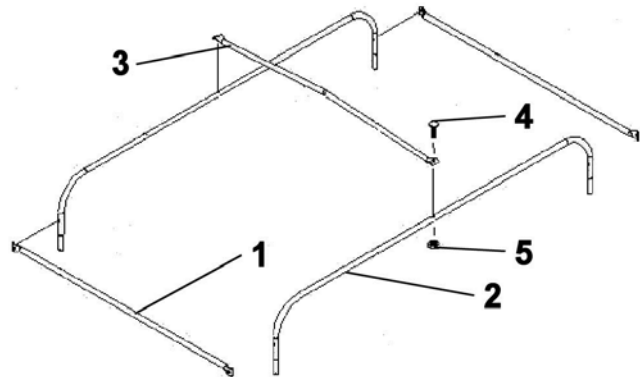

Figure 1

ASSEMBLY

STEP 2

TOW HITCH SUPPORT INSTALLATION:

NOTE: If you have a Berco counterweight kit installed on the back on the tractor, it is not necessary to install the tow hitch support (item 2) (except if the 700240 is installed). The rear support rods (item 1) of the cab will be inserted into the tubes welded to the right and left support plates of the counterweight kit.

Insert the rear support rods (fig.2, item 1), the longest end into tow hitch support (item 2). Install the tow hitch support on top of the tractor tow hitch (item 3) with a 1/2 x 1 1/2" hex bolt and two flat washers (one on top and the other under the tow hitch), lockwasher and nut. The support must be completely flat against the back of the tow hitch.

Tighten firmly.

Adjust the horizontal section of the rear rod support (fig.2, item A). So it is located 1/8" below the mud guard and 1" behind the mud guard.

Secure in place with two 5/16 x 5/16 set screws (item 4).

Tighten lightly.

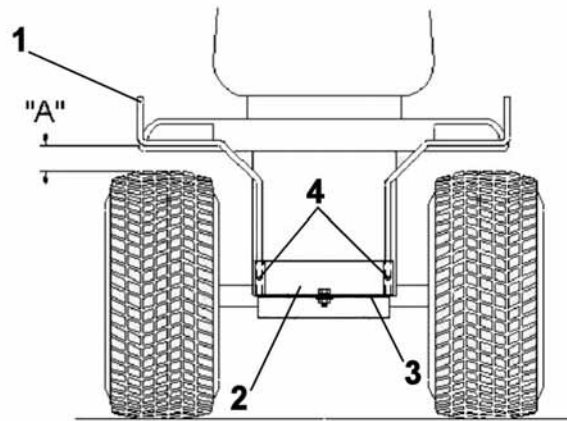

Figure 2

ASSEMBLY

STEP 3 FRONT ATTACHING PLATES INSTALLATION:

The supports furnished with this kit consist of three separate parts and can be installed in four different ways to adapt to the footrests.

BEFORE DRILLING HOLES IN FOOTRESTS

Determine the best location to mount the support plates by respecting the following:

- Plates must **NOT** interfere with any tractor pedals or controls such as brakes, clutch.

Tractors with snowblowers:

- Snowblower controls (lift arm and chute rotation support) must remain inside cab.

TIP: Temporarily install the whole cab on the tractor to get a global view of the installation before drilling the holes to attach the front supports. You can hold the supports temporarily in place with either C vice grips or C clamps until deciding where to secure it.

When the location has been determined, drill two 9/32" holes in each footrest. If needed, unclip and lift the rubber pads from the footrests. Install the front attaching plates (fig.3, item 4) under the footrests using two 1/4 x 3/4" machine screws (item 1) and flange nuts (item 5). Tighten firmly.

Fasten the front supports (item 6) to the attaching plates (item 4) with two 1/4 x 3/4" hex bolts (item 3) and flange nuts (item 5). Tighten firmly.

NOTE: On certain tractor models, the attaching plate (item 4) is not required. Simply bolt the front support (item 6) directly to the front lip of the footrest, after drilling the 9/32" holes.

Slide the front rod supports (item 7) into the front supports.

Adjust the width of the rods to 33" from one side of the tractor to the other. Secure in place with the 5/16 x 5/16" allen set screws (item 8).

Secure moderately.



WARNING



TO AVOID PERSONAL INJURY:

The front supports must not interfere in anyway with the brake & clutch pedals or any other tractor controls at any time. Any interference from the supports may block the controls and cause an accident.

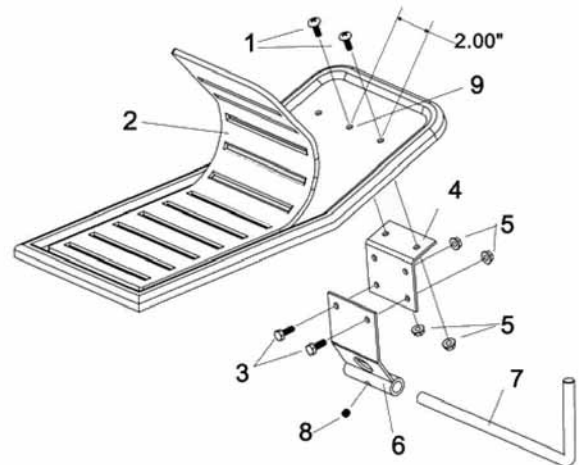

Figure 3

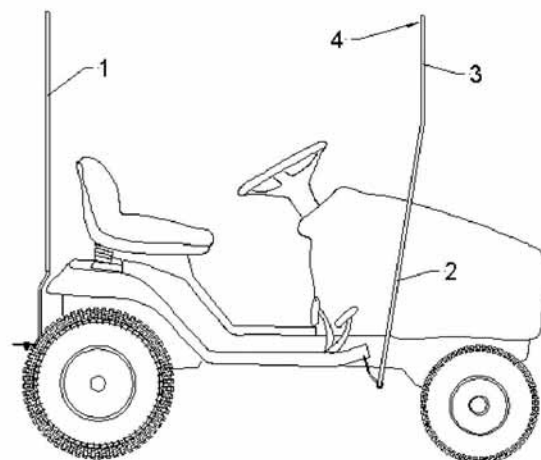

Figure 4

ASSEMBLY

STEP 4

FRAME ASSEMBLY:

Install the front posts (fig.5, item 2) the bent part towards the front and the back posts (item 1) as shown.

Place the roof section onto the posts .

NOTE:

If the roof is not even, adjust the front supports by screwing them in the other set of holes on the plates. If the posts need to be lengthened, place two sleeves on the support rods.

If front posts need to be shortened, cut bottom portion of posts as needed.

STEP 5

CANVAS INSTALLATION:

Install the cab cover over the frame. Use the Velcro straps to tie it down to the frame. The front of the cab is designed with an opening which allows access under the hood. This opening is equipped with Velcro tabs and straps with buckles at each end.

Attach the straps to the supports (fig.3, item 6) by inserting the buckles (fig.5, items 2 & 3) through the holes on the supports then snapping one end into the other.

Adjust the buckle (item 4) on top of the hood so that it is centered after adjusting all the other straps.

Once installation is complete, adjust the cab by pulling the rear support rods (fig.2, item 1) toward the back to achieve a snug fit.

Tighten all the nuts and screws firmly.

OPENING FOR HANDLE:

To accommodate the handle for the accessories, open the "Velcro" seam (item 1) on either side.

BEFORE INITIAL USE, PLEASE WIPE THE WHITE RESIDUE OFF THE WINDOWS WITH A DRY SOFT CLOTH.



WARNING



TO AVOID PERSONAL INJURY:

Make sure the cab cover does not touch the tractor's muffler or exhaust system. The cab may be damaged or even catch on fire.

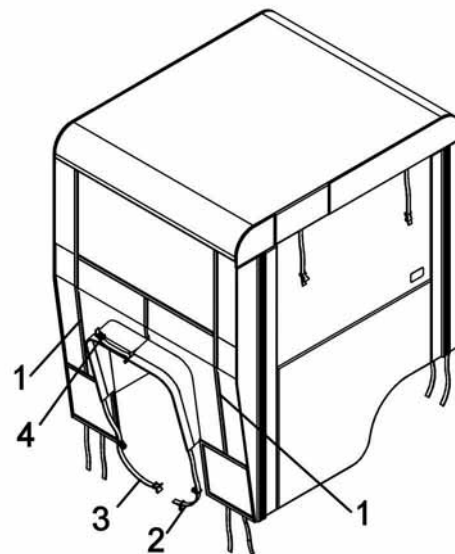

Figure 5



WARNING



TO AVOID PERSONAL INJURY:

Make sure the tractor's exhaust is in good condition and not oriented towards the cab.

EXHAUST FUMES SHOULD NEVER ENTER THE CAB, THEY CONTAIN CARBON MONOXIDE GAS

WHICH IS:

***ODOURLESS**

***COLORLESS**

***DEADLY**

NEVER BLOCK THE AIR VENTS

MAINTENANCE

MAINTENANCE

- a) Keep the windows clear and clean in order to keep a good visibility at all times. Wash the windows with a mild soap such as dishwashing soap and a soft cloth.
- b) Check mounting bolts on the frame at frequent intervals for proper tightness to be sure equipment is in safe working condition.
- c) During the winter use a soft brush to sweep off the snow. DO NOT HIT the windows with the brush or your hands to remove the snow. This will crack the vinyl.
- d) Keep air vents clear and clean at all times.

END OF SEASON STORAGE

- a) Thoroughly wash and dry the canvas.
- b) Inspect for any tears or unstitched seams. Repair if necessary.
- c) Carefully remove the canvas from the frame.
- d) Roll up instead of folding the canvas for summer storage.
- e) Store the canvas in a well ventilated place, away from all weather elements and out of reach of rodents.
- f) The frame must be cleaned and dried before storing in a dry enclosed place.
- e) Inspect and replace all defective parts before using again.

PARTS BREAKDOWN / NOMENCLATURE DES PIÈCES CAB / CABINE

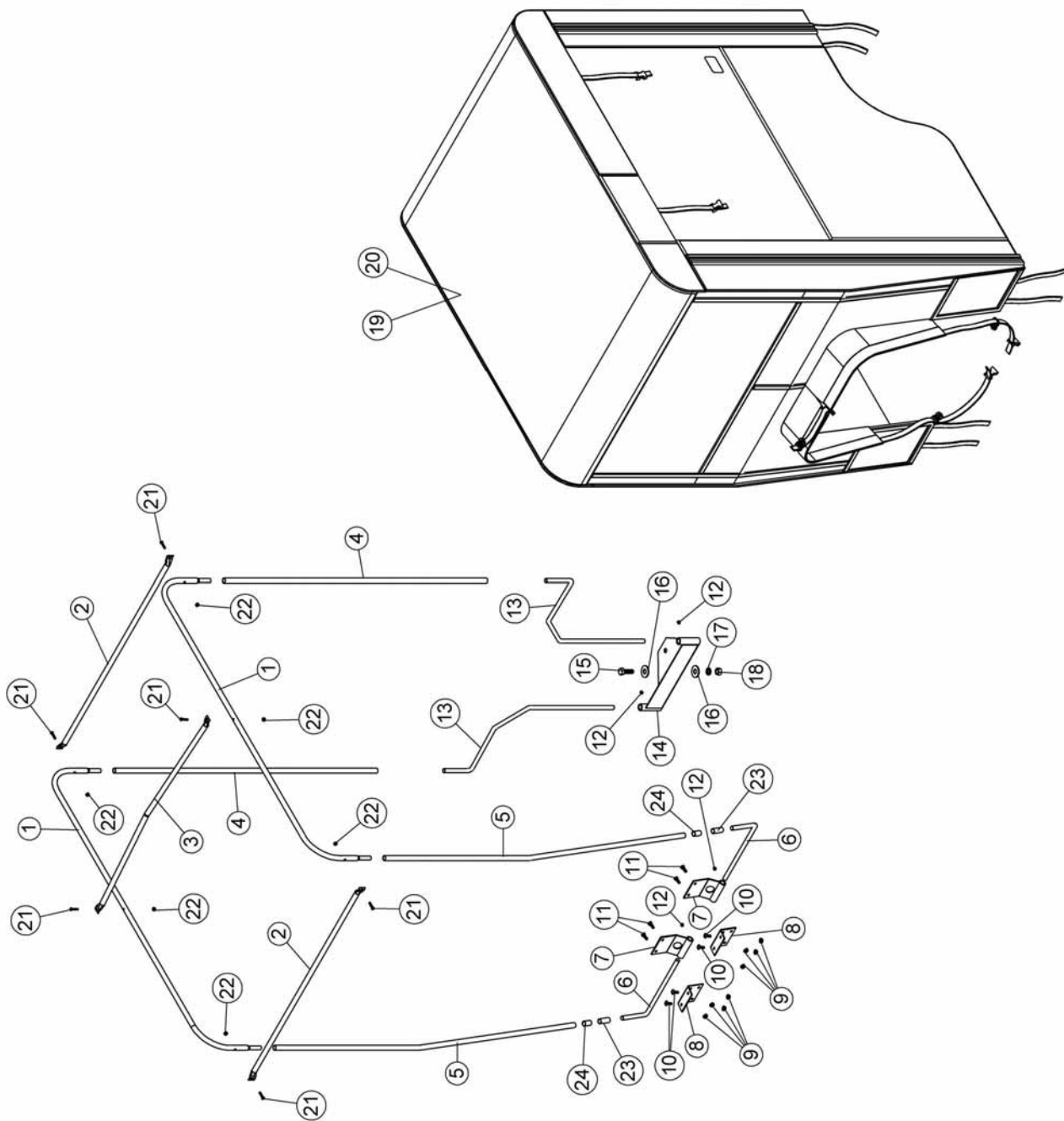

PARTS LIST / LISTE DES PIÈCES

Ref. Réf.	English description	Description française	Qty. Qté.	Part # Pièce #
1	Side tube	Tube de côté	2	102945
2	Link tube	Tube de liaison	2	102946
3	Reinforcement tube	Tube de renforcement	1	102947
4	Rear post	Poteau arrière	2	102948
5	Front post	Poteau avant	2	102949
6	Front rod support	Tige de support avant	2	102950
7	Front support	Support avant	2	102951
8	Front attaching plate	Plaque d'attache avant	2	102952
9	Flange nut 1/4" n.c.	Écrou à bride 1/4" n.c.	8	O/L
10	Machine screw T.H. 1/4" n.c. x 3/4"	Vis mécanique T.H. 1/4" n.c. x 3/4"	4	O/L
11	Hex. bolt 1/4" n.c. x 3/4"	Boulon hex. 1/4" n.c. x 3/4"	4	O/L
12	Hex. socket set screw 5/16" n.c. x 5/16"	Vis à pression hex. 5/16" n.c. x 5/16"	4	O/L
13	Rear rod support	Tige de support arrière	2	102953
14	Tow hitch support	Support de la barre de remorquage	1	102954
15	Hex. bolt 1/2" n.c. x 1 1/2"	Boulon hex. 1/2" n.c. x 1 1/2"	1	O/L
16	Flat washer 9/16" hole	Rondelle plate 9/16" trou	2	O/L
17	Lock washer 1/2"	Rondelle de blocage 1/2"	1	O/L
18	Hex. nut 1/2" n.c.	Écrou hex. 1/2" n.c.	1	O/L
19	Berco winter canvas	Toile d'hiver Berco	1	103006
20	Berco screen canvas	Toile moustiquaire Berco	1	103413
21	Machine screw P.H. #10 x 24 x 1"	Vis mécanique P.H. #10 x 24 x 1"	6	O/L
22	Nylon insert lock nut #10 x 24	Écrou à garniture de nylon #10 x 24	6	O/L
23	Sleeve	Douille	2	103215
24	Sleeve	Douille	2	104145

O/L = Obtain locally/obtenir localement