

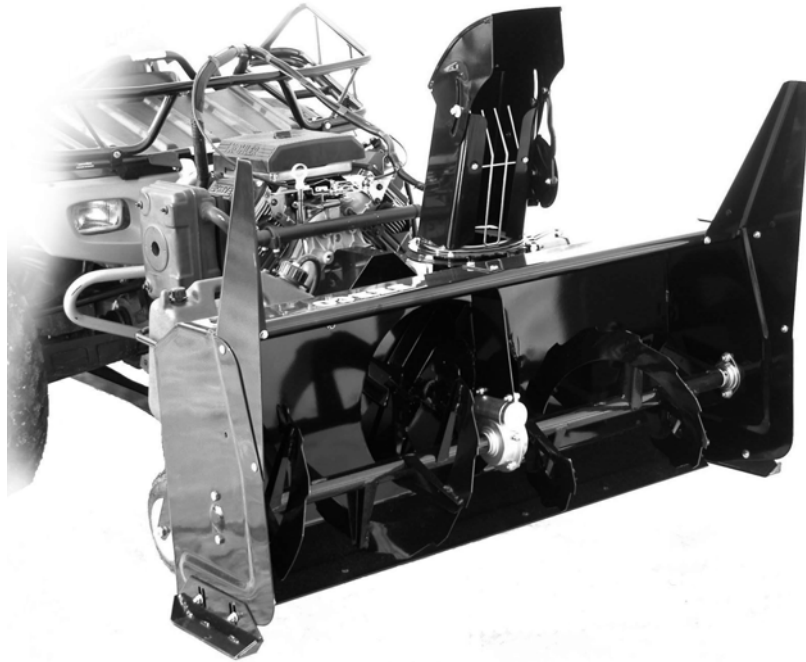

OWNER'S MANUAL
Model Number

700360-8 Snowblower



BERCO
54" SNOWBLOWER
for
ALL TERRAIN VEHICLES

- * ASSEMBLY
- * OPERATION

- * REPAIR PARTS
- * MAINTENANCE

CAUTION:
**READ & FOLLOW ALL SAFETY RULES & INSTRUCTIONS BEFORE
OPERATING YOUR EQUIPMENT**



LIMITED WARRANTY

Conditions and Products Covered:

BERCOMAC guarantees any part of the product or accessory manufactured by BERCOMAC and found in the reasonable judgment of BERCOMAC to be defective in material and or workmanship will be repaired or replaced by an authorized dealer without charge up to our maximum labor rates and pre-established times. For replacement parts only standard ground freight services are covered. This warranty extends to the original retail purchaser only and is not transferable to any subsequent purchasers.

Warranty Period

(from date of the original retail purchase):

- Residential use: 1 year
- Semi- commercial, professional or rental use: 90 days

Exceptions Noted Below; the following items are guaranteed by the original manufacturer and have their own warranty, conditions and limited time:

- Tire Chains: 90 days
- Engines: Will vary as per the manufacturer
Please refer to the engine manufacturer's warranty statement included with the unit. BERCOMAC is not authorized to handle warranty adjustments on engines.

Items and Conditions NOT Covered:

This warranty does not cover the following:

- Pick-up or delivery charges or in-home services fees.
- Any damage or deterioration of the unit, parts and or finish of these due to normal use, wear and tear, or exposure.
- Cost of regular use or maintenance service or parts, such as gas, oil, lubricants, tune-up parts, and adjustments.
- Any part or accessory which has been altered, modified, misused, neglected, accidentally damaged or not properly installed, maintained, stored or repaired not in accordance with the instructions in the owner's manual.
- Repair due to normal wear and or any wear items such as shear pins, bolts, belts, etc.
- Expedited freight fee services for replacement parts.
- Shear bolts and shear pins are to be considered as a preventive measure not as an assured protection, any damages resulting from the lack of shear bolts breakage are not covered.

NOTE: All warranty work must be performed by an authorized dealer using original (manufacturer) replacement parts.

NOTE: Bercomac reserves the right to change or improve the design of any part or accessory without assuming any obligation to modify any product previously manufactured.

Instructions for Obtaining Warranty Services:

Contact dealer where equipment was purchased or any other authorized service dealer to arrange service at their dealership. Requests for warranty claims must be carried out through the same distribution network used to purchase the product. Don't forget to bring your proof of purchase (sales receipt) to the dealer.

Owner's Responsibilities:

Any defective equipment or part must be returned to an authorized dealer within the warranty period for repairs. In the event that defective merchandise must be returned to manufacturer for repairs, the dealer must first obtain a written authorization from either KIMPEX or BERCOMAC, freight fees are prepaid prior to the shipment. This warranty extends only to equipment operated under normal conditions. To validate a warranty claim, it is the user's responsibility to maintain and service the unit as specified in the owner's manual or to have the unit serviced at their dealer at their expense.

General Conditions:

The sole liability of BERCOMAC with respect to this warranty shall be strictly and exclusively repair and replacement as mentioned herein. BERCOMAC shall not have any liability for any other costs, loss or damage, including but not limited to, any incidental or consequential loss or damage.

In particular, without being limited to, BERCOMAC shall have no liability or responsibility for:

- Travel time, overtime, after hours time or other extraordinary repair charges or relating to repairs and or replacements outside of normal business hours.
- Rental of like or similar replacement equipment during the period of any, repair or replacement work.
- Any communicating or travel charges.
- Loss or damage to person or property other than that covered by the terms of this warranty.
- Any claims for lost revenue, lost profit or any similar costs as a result of damage or repair.
- Attorney's fees.

BERCOMAC's responsibility in respect to claims is limited to making the required repairs or replacement without charge up to our maximum labor rates and pre-established times and no claim of breach of warranty shall be cause for cancellation or rescission of the contract of sale of any product or accessory.

This warranty gives you specific legal rights. You may also have other rights, which vary from state to state.

TABLE OF CONTENTS

PAGE

INTRODUCTION	2
SAFETY PRECAUTIONS	3
SAFETY DECALS	5
ASSEMBLY	
Conversion Table, Glossary, Tools Required	6
Step 1: Vehicle Preparation	7
Step 2: Subframe Preparation	7
Installing the Winch Hook	11
Verify Skid Shoe Adjustment	11
Step 3: Engine Preparation	12
Saddle Preparation	12
OPERATION	
Operating the Snowblower	13
Electric Controls	13
Removing Snow	13
Clearing a Clogged Chute	13
MAINTENANCE	
Maintenance	14
Adjustments	14
Lubrication	14
Cutting Edge Maintenance	14
Snowblower Pulley Replacement	14
Auger and Fan Shear Bolt Replacement	14
BELT REPLACEMENT	14
BELT ADJUSTMENTS	14
REPLACEMENT OF ONE OR TWO SECTIONS OF THE AUGER AND /OR GEAR BOX	14
DISMOUNTING & STORAGE	19
TROUBLESHOOTING	20
TORQUE SPECIFICATION TABLE	21
PARTS BREAKDOWN AND PARTS LIST	
Rotation System with Chute	22
Saddle Assembly	24
Subframe	26
Snowblower	28
OPTIONS	32

INTRODUCTION

TO THE PURCHASER

This new accessory was carefully designed to give years of dependable service. This manual has been provided to assist in the safe operation and servicing of your attachment.

NOTE: All photographs and illustrations in the manual may not necessarily depict the actual models or attachment, but are intended for reference only and are based on the latest product information available at the time of publication.

Familiarize yourself fully with the safety recommendations and operating procedures before putting the machine to use. Carefully read, understand and follow these recommendations and insist that they be followed by those who will use this attachment.



THIS SAFETY ALERT SYMBOL IDENTIFIES AN IMPORTANT SAFETY MESSAGE IN THIS MANUAL THAT HELPS YOU AND OTHERS AVOID PERSONAL INJURY OR EVEN DEATH. DANGER, WARNING, AND CAUTION ARE SIGNAL WORDS USED TO IDENTIFY THE LEVEL OF HAZARD. HOWEVER, REGARDLESS OF THE HAZARD, BE EXTREMELY CAREFUL.

DANGER: Signals an extreme hazard that will cause serious injury or death if recommended precautions are not followed.

WARNING: Signals a hazard that may cause serious injury or death if the recommended precautions are not followed.

CAUTION: Signals a hazard that may cause minor or moderate injury if the recommended precautions are not followed.

Record your attachment serial number and purchase date in the section reserved below (there is no serial number on the subframe). Your dealer requires this information to give you prompt, efficient service when ordering replacement parts. Use only genuine parts when replacements are required.

If warranty repairs are required please present this registration booklet and original sales invoice to your selling dealer for warranty service.

**This manual should be kept for future reference.
Please check if you have received all the parts for your kit with the list of the bag and the list of the box.**

SERIAL NUMBER : (IF APPLICABLE)	
MODEL NUMBER:	
PURCHASE DATE :	



SAFETY PRECAUTIONS



Careful operation is your best insurance against an accident. Read this section carefully before operating the vehicle and accessory. This accessory is capable of amputating hands and feet and throwing objects. Failure to observe the following safety instructions could result in serious injury. All operators, no matter how experienced they may be, should read this and other manuals related to the vehicle and accessory before operating. It is the owner's legal obligation to instruct all operators in safe operation of the accessory.

GLOSSARY:

In this manual, right and left sides are determined by sitting on the seat of the vehicle facing forward.

In this manual, "accessories" means attachments (snowblower, rotary broom, blade etc.) that you install on the vehicle (lawn tractors, A.T.V. s etc).

TRAINING:



This symbol, "Safety Alert Symbol", is used throughout this manual and on the accessory's safety labels to warn of the possibility of serious injury. Please take special care in reading and understanding the safety precautions before operating the vehicle and accessory.

1. Read this owner's manual carefully. Be thoroughly familiar with the controls and proper use of the vehicle and accessory. Know how to stop the unit and disengage the controls quickly.
2. Never allow children to operate the vehicle nor the accessory. Never allow adults to operate the vehicle nor the accessory without proper instructions.
3. No one should operate the vehicle nor the accessory while intoxicated or while taking medication that impairs the senses or reactions.
4. Keep the area of operation clear of all people, particularly small children and pets.

PREPARATION:

1. Thoroughly inspect the area where the accessory is to be used and remove door mats, all foreign objects and the like.
2. For motorized accessories, disengage all clutches and shift into neutral before starting engine.
3. Do not operate the accessory without wearing adequate winter outer garments. Avoid loose fitting clothing that can get caught in moving parts. Wear footwear that will improve footing on slippery surfaces.

4. Handle fuel with care, it is highly flammable.

- a) Use approved fuel container.
 - b) Never add fuel to a running engine or hot engine.
 - c) Fill fuel tank outdoors with extreme care. Never fill fuel tank indoors.
 - d) Never fill containers inside a vehicle, or on a truck or a trailer bed with a plastic liner. Always place containers on the ground, away from your vehicle, before filling.
 - e) When practical, remove gas-powered equipment from the truck or trailer and refuel it on the ground. If this is not possible, then refuel such equipment on a trailer with a portable container, rather than from a gasoline dispenser nozzle.
 - f) Keep the nozzle in contact with the rim of the fuel tank or container opening at all times, until refueling is complete. Do not use a nozzle lock-open device.
 - g) Replace fuel cap securely and wipe up spilled fuel.
 - h) If fuel is spilled on clothing, change clothing immediately.
5. Never attempt to make any adjustments while the engine (motor) is running (except when specifically recommended by manufacturer).
 6. Let the vehicle and accessory adjust to outdoor temperatures before using.
 7. Never use an accessory without proper guards, plates, or other safety protective devices in place
 8. Always make sure to wear the appropriate safety equipment required (glasses, muffs, mask...) for each type of product. See operation section.
 9. Always make sure of having safe traction on the vehicle by using the recommended accessories (chains, A.T.V. tracks, counterweights...). See operation section.
 10. Always make sure the all components are correctly installed. (driveline securely attached and locked at both ends, belts properly installed...)
 11. **Never modify the accessory or any part without the written consent from the manufacturer.**



SAFETY PRECAUTIONS



OPERATION:

1. Do not put hands or feet near, under or inside rotating parts.
2. Exercise extreme caution when operating on or crossing gravel drives, walks or roads. Stay alert for hidden hazards or traffic. Do not carry passengers.
3. After striking a foreign object, stop the engine (motor), disconnect the wire from the spark plug(s) and keep wire away to prevent accidental starting. Thoroughly inspect the accessory for any damage and repair damage before restarting and using the accessory.
4. If the unit should start to vibrate abnormally, stop the engine (motor) and check immediately for the cause. Vibration is generally a warning of trouble.
5. Take all possible precautions when leaving the vehicle unattended. Disengage the power take-off, lower the attachment, place the transmission into neutral, set the parking brake, stop the engine and remove the contact key.
6. Do not run the engine indoors, except when starting the engine and for transporting in or out of the building. Do not operate or let motor run in a storage area without ventilation because gas contains carbon monoxide which is odorless, colorless and can cause death.
7. Never use the accessories across the face of slopes, go from top to bottom. Exercise extreme caution when using equipment on slopes. Do not attempt to clear a steep slope.
8. Never tolerate bystanders in the working zone. Never use an accessory in the direction of bystanders, it might throw gravel or debris that can hurt people or damage property.
9. Never operate the accessory at high transport speeds on slippery surfaces. Use care when backing up.
10. Do not carry passengers.
11. Disengage power to the accessory when it is transported or not in use.
12. Never operate the accessory without good visibility or light.

13. Keep the accessory away from heat sources or flames.

MAINTENANCE AND STORAGE

1. When cleaning, repairing or inspecting the vehicle and accessory, make certain that all moving parts have stopped. For gasoline engine, disconnect wire from the spark plug(s) and keep wire away to prevent accidental starting.
2. Check all the bolts and components at frequent intervals to make sure that they are properly tightened.
3. Never store a motorized accessory with fuel in the fuel tank inside a building where ignition sources are present such as hot water and space heaters, clothes dryers, and the like. Allow the engine to cool before storing in any enclosure.
4. Always refer to the owner's manual when you store the accessory and vehicle for a prolonged or an unspecified length of time.
5. Maintain or replace safety and instruction labels, as necessary.
6. For winter accessories, (if applicable), let the engine run for a few minutes after clean snow in order to prevent the rotary parts from freezing.
7. Inspect the vehicle's and accessory's air filter (if applicable) every day. Clean it or replace it as necessary. Change the oil more often when working in dusty conditions. See the vehicle's and accessory's owner's manual.



**THIS SYMBOL MEANS
DANGER !
BECOME ALERT !
YOUR SAFETY IS INVOLVED !**



SAFETY DECALS



**REPLACE IF DECALS ARE DAMAGED
SEE PARTS BREAKDOWN FOR DECAL LOCATION**

DECAL #105126



To avoid serious injury:
Keep hands, feet & clothing away from rotating auger while engine is running.

DECAL #105130

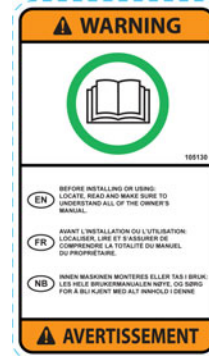

Before installing or using:
Locate, read and make sure to understand all of the owner's manual.

DECAL #105127



To avoid serious injury:
Keep hands out of this discharge chute while engine is running.

DECAL #105131

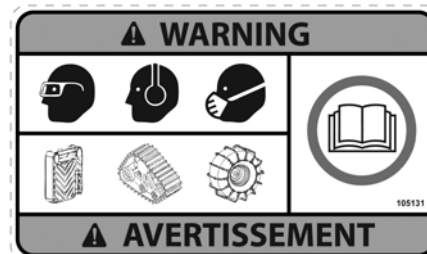

Refer to owner's manual about wearing safety glasses, ear muffs and mask.
Refer to owner's manual for use of counter weights, cat tracks and tire chains.

DECAL #105128



To avoid injury from drive belt:
Keep hands, feet & clothing away.
Do not attempt to install or remove drive belt without reading owner's manual.

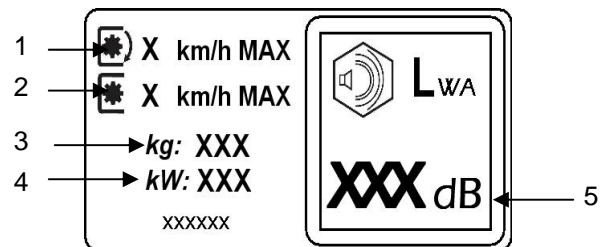

- 1-Do not drive faster than 3 KM/H when the snowblower is in operation.
- 2-Do not drive faster than 10 KM/H when the snowblower is in the raised position.
- 3-The head of the snowblower weighs 190kg.
- 4-The engine wattage is 17.2kW.
- 5-The sound pressure level is measured at the engine (full charge at 3600 RPM) by the Kholer company.

ASSEMBLY

CONVERSION TABLE

1" (po, in)	25.4 mm
1' (pi, ft)	0.3 m
1 psi (lb/in ²)	6.89 kPa
1 lb	0.45 kg
1 lbf	4.4 N
1 m/h (mi/h)	1.61 km
1 hp (cv)	0.75 kW

GLOSSARY

Quad = V.T.T., A.T.V.	
Véhicule tout terrain	V.T.T.
All terrain vehicle	A.T.V.
P.T.O. = P.D.F	
Power take-off	(P.T.O)
Prise de force	(P.D.F)

IMPORTANT: TORQUE ALL BOLTS ACCORDING TO TORQUE SPECIFICATION TABLE (SEE TABLE OF CONTENTS) WHEN STATED: TIGHTEN FIRMLY. REFER TO PARTS BREAKDOWN SECTION FOR PART IDENTIFICATION.

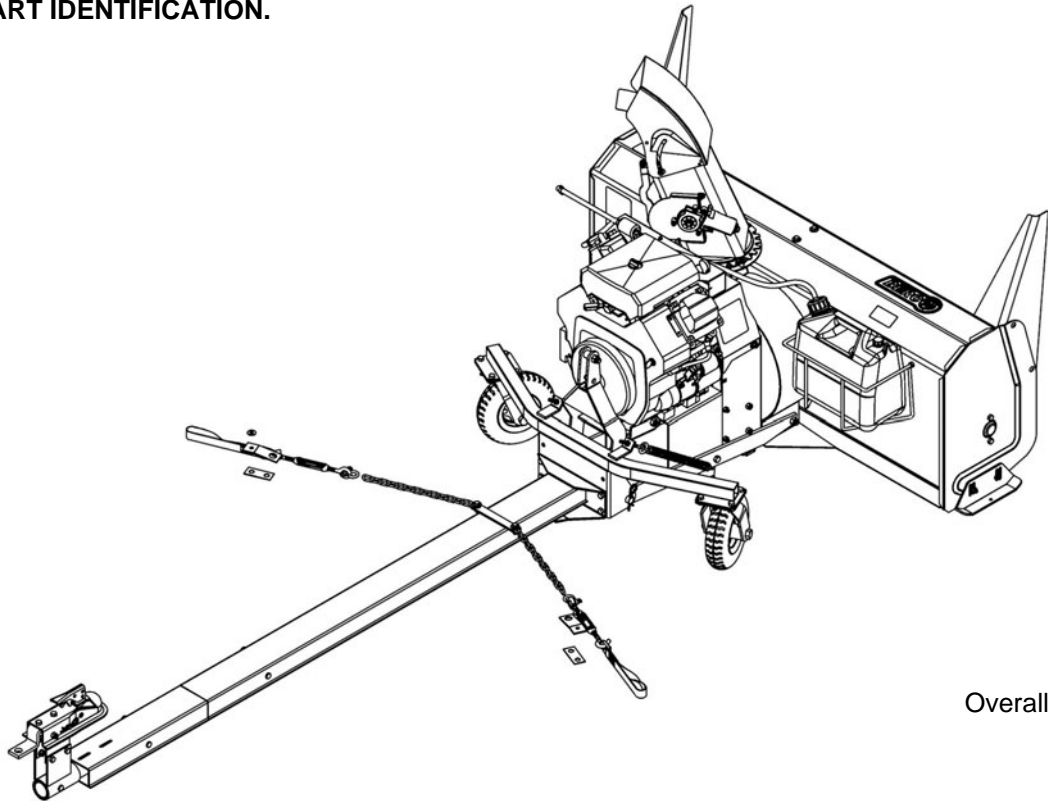

Overall view

TOOLS REQUIRED

- 3 Wrenches 9/16", 1/2", 3/4"
- 1 Ratchet
- 3 Sockets 9/16", 1/2", 3/4"
- 1 Wrench (for the nuts on the vehicle's battery posts)
- 1 Wooden block

ASSEMBLY

STEP 1

VEHICLE PREPARATION:

NOTE: A 1 7/8" tow hitch ball is required.

Choose among the three different options to prepare your vehicle (A, B, C).

A) Install the lift strap (item 1) by looping it around the suspension arm (as shown) on the vehicle. Tighten the loop firmly.

# Item	Description	Action
B) Install the brackets (item 3) on both sides of vehicle.		
	Bolt and nut from suspension arm	Remove.
2-3	Flat washer and bracket	Install and lightly secure with the original bolt and nut.
C) Install the brackets (item 4) on both sides of vehicle.		
	Nut from suspension arm	Remove.
4	Bracket	Install and lightly secure with the original nut.

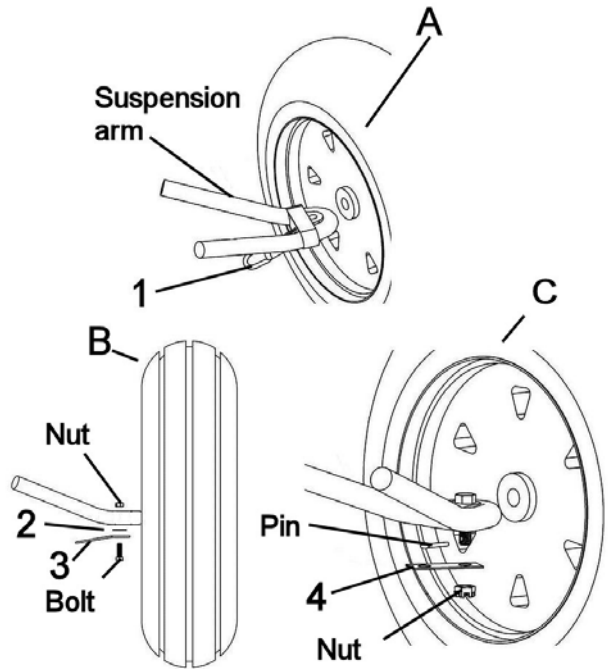

Install the lift strap or the brackets.

STEP 2

SUBFRAME PREPARATION:

NOTE: Determine according to the height of the vehicle which set of holes to use to assemble the wheel support (item 1) to the subframe* (See below).

Install the wheel support (item 1).		
# Item	Description	Action
1	Wheel support	Install to the subframe*.
2	Hex bolts 3/8" x 1" (qty 4)	Insert as shown
3	Flange nuts 3/8" (qty 4)	Tighten firmly
*The subframe must be parallel with the ground when the subframe is installed under the vehicle.		

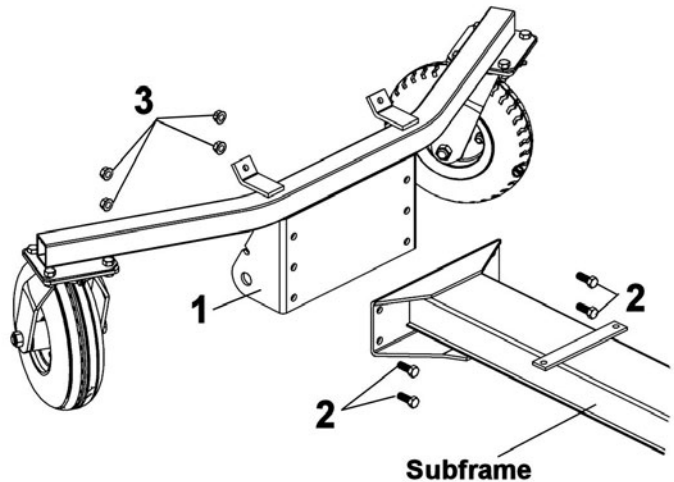

Install the wheel support

ASSEMBLY

Install the assembled turnbuckles (item 1).

# Item	Description	Action
1	Assembled turnbuckle (qty 2)	Install on subframe as shown.
2	Flat washer 3/8" (qty 2)	Install on the assembled turnbuckles as shown.
3	Hex bolt 5/16" x 1" (qty 2)	Insert as shown.
4	Nylon insert lock nut 5/16" (qty 2)	Install and tighten firmly.

NOTE: Position the chains as shown and tighten firmly.

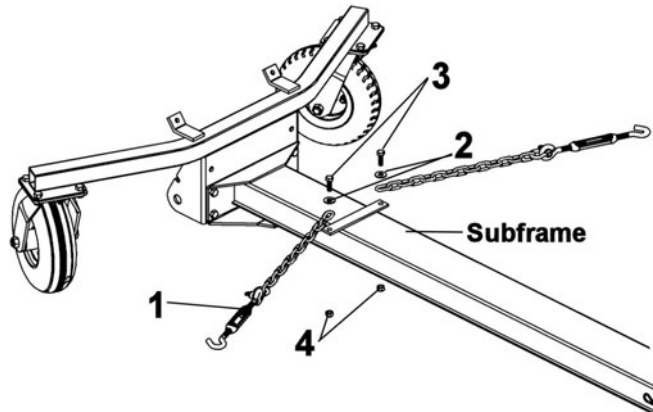

Install the assembled turnbuckles

NOTE: Remove hair pin (item 2) from the pin (item 1). Remove the pin from the lever.

Install the lift lever of snowblower on the assembled subframe.

# Item	Description	Action
1	Pin	Insert the pin through the holes on the assembled subframe and lever of the snowblower as shown*.
2	Hair pin 4mm	Secure pin as shown.

*Make sure the pin is in the locked position.

TIP: The use of a wooden block under the lever helps for this installation.

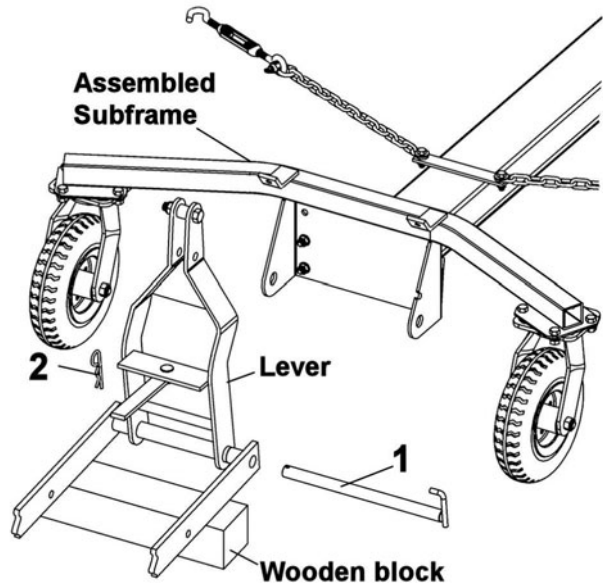

Install the lever of the snowblower

ASSEMBLY

Install the springs (item 2) on each side.		
# Item	Description	Action
1	Hex nut 5/16" (qty 2)	Insert on each eye bolt (item 3). Tighten about half way down.
2	Spring (qty 2)	Insert the spring into the spring link and hook the other end into the eye bolt.
3	Eye bolt (qty 2)	Insert into the hole in the link of the wheel support.
4	Flat washer 3/8" (qty 2)	Insert on eye bolt as shown.
5	Nylon insert lock nut 5/16" (qty 2)	Tighten firmly.
Tighten the nut to apply tension on the spring. Do the same procedure for both springs.		

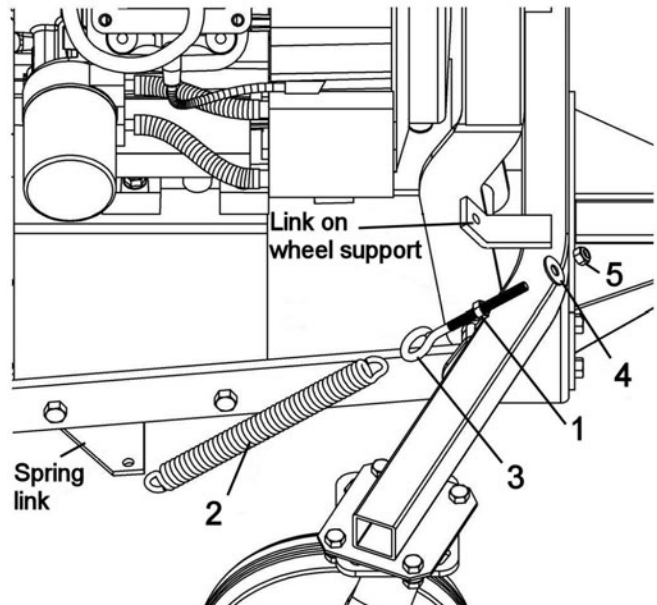

Install the springs.

You have seven different positions on the adjustment tube (item 1) (the adjustment tube can be inverted) to adjust the length of the subframe.

To choose the right adjustment, insert the adjustment tube (item 1) into the subframe (item 2) and insert the rear bracket (item 3) on the adjustment tube. Do not secure.

Drive the vehicle over the subframe, make sure the caster wheels do not touch the front wheels on the vehicle.

Identify the right length and secure in place with the pins (item 4) and 3mm hair pins (item 5).

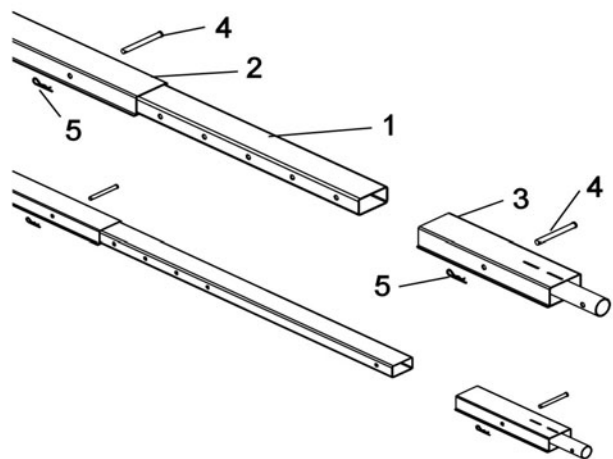

Adjust length of subframe

ASSEMBLY

Choose between the three positions (see figure), the height of the hitch support.

There must be a maximum of ground clearance according to your vehicle.

Position A does not have the hitch support plates (item 1).

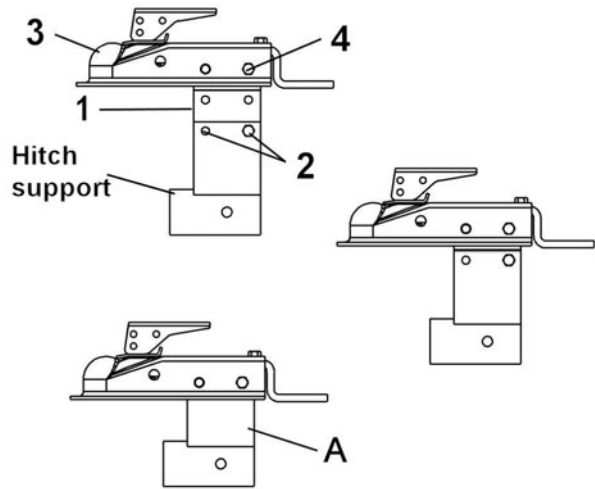

Assemble the hitch support

Assemble the hitch supports (item 1).

# Item	Description	Action
1	Hitch support plate (qty 2)	Assemble the hitch support plates on the hitch support.
2	Hex bolt 3/8" x 3/4" (qty 4)	Insert in the chosen holes, (two on each side) and secure with the lock washers 3/8". Tighten firmly.
3	Hitch	Insert on the two hitch supports plates (if applicable).
4	Hex bolt 3/8 x 3" (qty 1)	Insert in the hole as shown and secure with a 3/8" nylon lock nut. Tighten firmly.

Install the assembled hitch support (item 1) on the **vehicle's** tow hitch ball.

# Item	Description	Action
1	Assembled hitch support	Insert onto the rear bracket.
2-3	Pin and 3mm hair pin	Secure in place.
4	Assembled hitch support	Attach on the vehicle's tow hitch ball.
5-6	Pin and 3mm hair pin	Secure in place.

Make sure the subframe does not come into contact with vehicle at any time.

NOTE: You can turn the hitch assembly (item 1) by removing the pin (item 2) to facilitate driving the vehicle over the subframe.

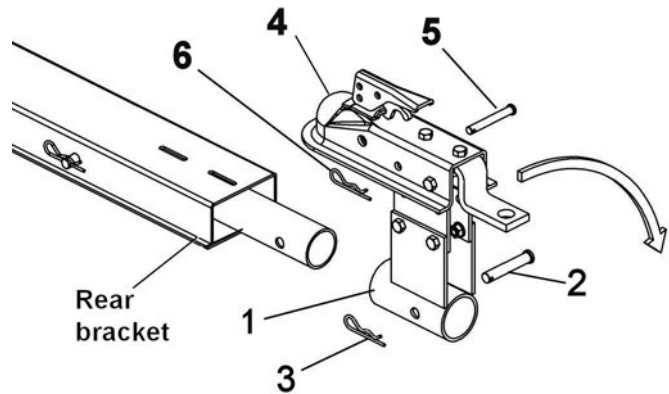

Secure the assembled hitch support on the tow hitch ball

WARNING : Always check that ball is completely inserted into hitch coupler socket and that the underjaw is securely closed around the bottom of ball. Always check tightness before using the tow hitch. If necessary, tighten locknut against tension spring. Be sure hitch coupler handle is in locked position.

ASSEMBLY

Install the turnbuckles (item 1) into the brackets or into the lift straps.

# Item	Description	Action
1	Turnbuckle (qty 2)	Adjust them so that the subframe is centered under the vehicle .*

*Tighten the turnbuckles firmly in order to tighten the vehicle's suspension.

IMPORTANT: After adjusting the turnbuckles, tighten the nuts on the vehicle's suspension arms firmly. Make sure to lock the nuts with the original locks.

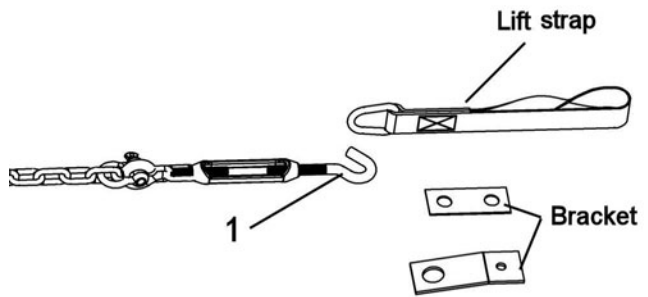

Install the turnbuckles

Attach the **vehicle's** winch's hook on the lever rod

# Item	Description	Action
If the vehicle's winch is higher than 20" (510mm) from the ground,		
1	Sleeve	Install in the top hole of the lever.
If the vehicle's winch is lower than 20" (510mm) from the ground,		
1	Sleeve	Install in the bottom hole of the lever.
2	Hex bolt 1/2" x 2 1/4" and nylon insert lock nut	Tighten firmly.
	Vehicle's winch's hook .	Install on the lever rod as shown.

Tip: Thread the winch's hook in front of the lever as shown and then thread the cable over the sleeve.

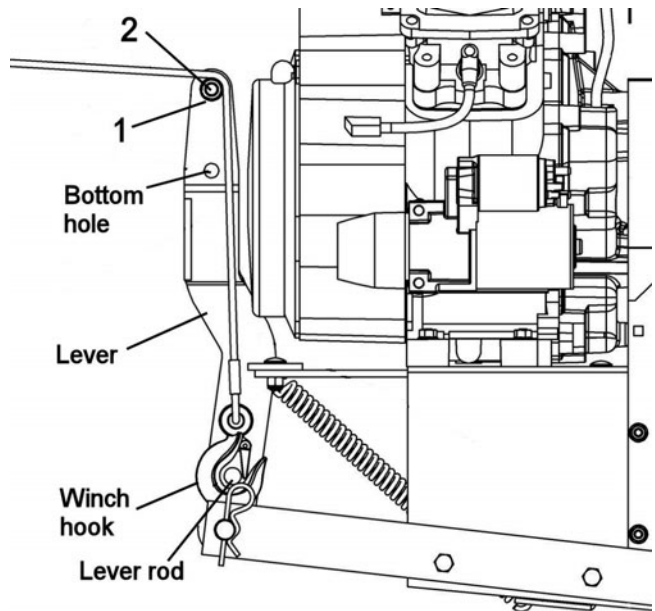

Install the winch hook

VERIFY SKID SHOE ADJUSTMENT:

LEVEL PAVED SURFACE: Adjust skid shoes to allow 3/16" to 1/4" or 5mm to 7mm clearance (A) between cutting edge and surface.

UNEVEN OR GRAVEL SURFACE: Adjust skid shoes to allow 1/2" to 5/8" or 13mm to 16mm clearance (A) between cutting edge and surface.

VERIFY TIRE PRESSURE:

Check and adjust the pressure of the tires on subframe to 50 psi.

Tire pressure must be even on both sides..

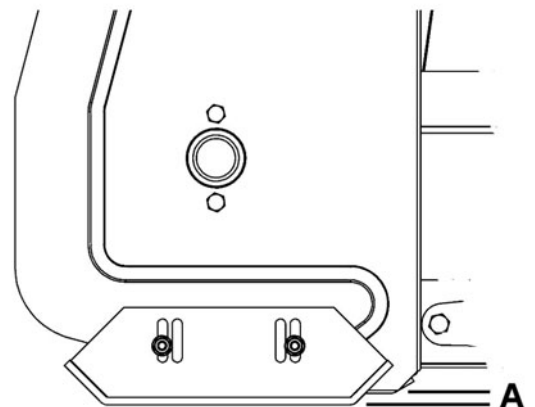

Adjust skid shoes

ASSEMBLY

STEP 3

ENGINE PREPARATION:



CAUTION



Oil must be added to this motor.

Please refer to motor's owner's manual for instructions and proper winter oil recommendations.

Connecting the wire assembly:

The kit is equipped with a connector which will permit you to remove the snowblower quickly without having to remove the wiring.

Place and tie the wires in an appropriate place under the A.T.V. since they will stay there permanently.

Connect the red wire (positive) to the ATV battery.
Connect the black wire (negative) on a bolt that is on the A.T.V. frame (scrape away any paint to make sure the contact is good) and retighten the bolt.

Fill the gas tank with unleaded gasoline.

Wipe off any spilled gasoline.

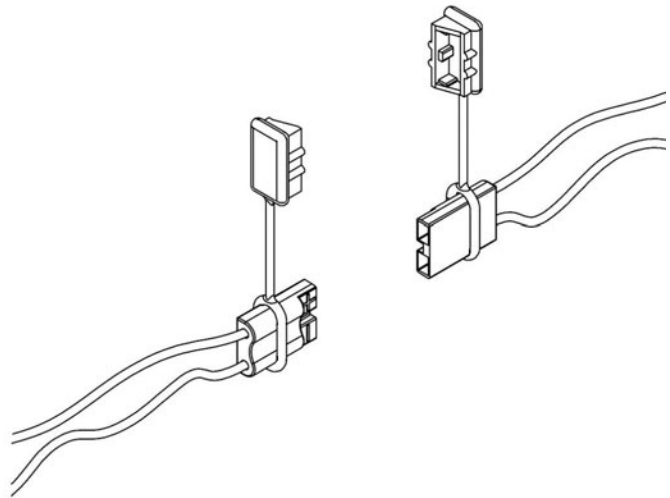

Wire assembly

SADDLE PREPARATION:

NOTE: All the electrical system is already installed and connected to the various snowblower components.

Place the saddle assembly on the A.T.V. seat.
Place and tie the wire protector in an appropriate place so the wire protector does not interfere with any hot or moving parts

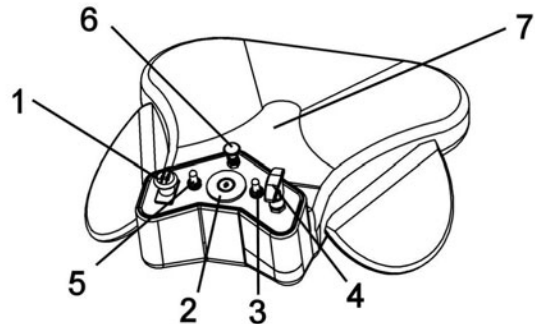

Saddle controls

- Item 1: P.T.O. Switch
- Item 2: Ignition Switch
- Item 3: Switch (deflector)
- Item 4: Throttle Control
- Item 5: Switch (chute rotation)
- Item 6: Choke Control
- Item 7: Safety Switch

OPERATION

OPERATING THE SNOWBLOWER

You must be sitting on the saddle in order to start the snowblower engine.

- Make sure the snowblower is clear of snow before engaging the snowblower.
- Make sure that the auger and fan operate freely.
- Start the snowblower engine.
- Before engaging the snowblower drive, always have the engine running at medium R.P.M.
- Operate the snowblower at maximum engine R.P.M.

IMPORTANT: USE FULL ENGINE R.P.M. WHEN REMOVING WET, STICKY SNOW. LOW R.P.M. POWER WILL TEND TO PLUG THE CHUTE.

ELECTRIC CONTROLS

See saddle preparation for identification of the saddle controls.

RAISING AND LOWERING THE SNOWBLOWER:

Use the winch switch control to raise and lower the snowblower.

IMPORTANT: To prolong the subframe's life, release the switch immediately when the attachment hits the stopper in the highest position.

TURNING THE CHUTE AND DEFLECTOR:

Use the switches on the saddle to turn the chute and to raise or lower the deflector.

ENGAGING AND DISENGAGING THE SNOWBLOWER:

Engage the snowblower when the engine is running at medium R.P.M. by pulling the P.T.O. switch.

REMOVING SNOW

When removing snow, do not use the snowblower as a dozer blade to push snow. Allow snowblower to ingest snow at its own speed. If the speed of your A.T.V. is too fast, the snowblower may become overloaded and plug. For best results, raise the snowblower and remove a top layer of snow. A second pass with the snowblower will remove the remaining snow.



WARNING



Read the A.T.V.'s owner's manual carefully. Be thoroughly familiar with the controls & proper use of the attachment. Know how to stop the unit & disengage the controls quickly.



WARNING



TO PREVENT INJURIES AND FOR MORE TRACTION WHEN USING SNOWBLOWER:

- Do not drive faster than 3 km/hr (2 m/hr) with snowblower on the ground.
- Do not drive faster than 10 km/hr (6 m/hr) with the snowblower in raised position.
- Do not operate on a slope greater than 10°.
- A.T.V. manufacturer approved tire chains are required.
- Maximum drawbar pull provided for at the hitch ball coupling: 3560N (800 lbs)
- Maximum vertical load provided for on the hitch ball coupling: 360N (80 lbs)



WARNING



- Do not attempt to clear plugged chute, auger or fan of snow while the snowblower's engine is running.
- Disengage snowblower.
- Lower snowblower onto ground.
- Set the parking brake.
- Stop engine, remove the ignition key, disconnect the wire from spark plug(s) and keep away from spark plug(s) to prevent accidental starting.
- Make sure all moving parts have stopped.
- Do not use hand to unplug chute.
- Use a 36" (1m) minimum length stick or board.

CLEARING A CLOGGED DISCHARGE CHUTE:

Hand contact with the rotating impeller inside the discharge chute is the most common cause of injury associated with snowblowers. Never use your hand to clean out the discharge chute.

To clear the chute:

- Lower snowblower to the ground and set parking brake.
- SHUT THE ENGINE OFF & REMOVE KEY!
- Wait 10 seconds to be sure that **all moving parts** such as the impeller blades have stopped moving.
- Disconnect wire from the spark plug(s) and keep wire away to prevent accidental starting.
- Always use a clean-out tool of at least 36" in (1 m) length, NEVER YOUR HANDS.

MAINTENANCE



WARNING



TO PREVENT INJURIES:

Stop the snowblower motor.
Apply parking brake.
Remove the ignition key.
Disconnect the wire from the spark plug(s) and keep away from spark plug(s) to prevent accidental starting.

MAINTENANCE

- Check mounting bolts at frequent intervals for proper tightness in order to prevent costly repairs. Make sure your snowblower is in safe working condition.
- Provide adequate blocking before working under the snowblower when in raised position.

ADJUSTMENTS

SKID SHOE ADJUSTMENT:

Level Paved Surface: Adjust skid shoes to allow 3/16" to 1/4" clearance between cutting edge and surface.

Uneven or Gravel Surface: Adjust skid shoes to allow 1/2" to 5/8" clearance between cutting edge and surface.

CUTTING EDGE MAINTENANCE

Verify from time to time the wearing on the cutting edge to make sure you do not wear out the base of the snowblower's chassis. This cutting edge is reversible.

SNOWBLOWER PULLEY REPLACEMENT or ALIGNMENT:

Clean the parts before aligning or replacing the pulley. Apply some "Loctite" 2760 on the key and the set screws. Tighten firmly. (Use heat to soften the "loctite" when removing the set screws).

LUBRICATION

Grease the wheel axles, the fork pivots after every sixteen hours of use.

Apply oil at all pivot points.

Chute Rotation System: Oil chute base, rotation worm every sixteen hours of operation.

Gear box:

Check the oil annually. If necessary, add AGMA 5 EP or SAE 90 oil.

The gear box should have a total of 155 ml of oil or filled to the rim of the bolt hole when installed on the snowblower. (see figure)

AUGERS AND FAN SHEAR BOLT REPLACEMENT

Shear bolts are to be considered a preventive measure and not an assured protection. Operator vigilance is required. Thoroughly inspect the areas where the snowblower is to be used and remove all foreign objects.

To avoid damage to the snowblower:

Use only the original shear bolts (grooved bolts).

#104000 in bags of 10 for the augers.

#103999 in bags of 10 for the fan.

The use of any other shear bolt will not insure any protection and may void the warranty.

IMPORTANT: IT IS VERY IMPORTANT TO REPLACE THE AUGERS IN THE SAME POSITION AS SHOWN IN THE DRAWING BEFORE INSTALLING THE SHEAR BOLTS.

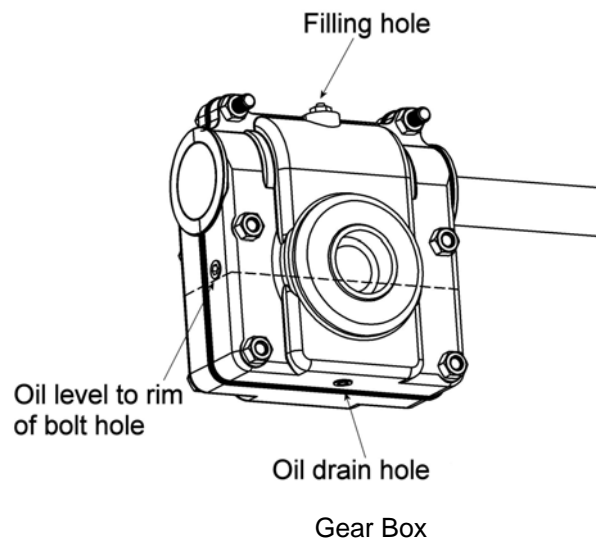
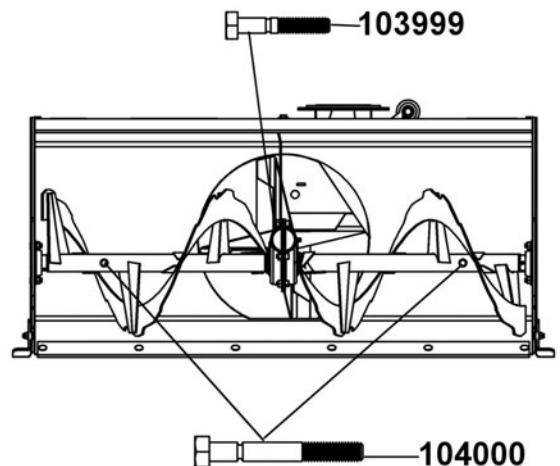

BELT REPLACEMENT

BELT REPLACEMENT:

For belt part numbers, refer to snowblower parts breakdown section for parts identification
Snowblower must be detached & disconnected from the A.T.V. to replace belts.

V-Belt:

- a) Remove the belt guard (item 1)
- b) Remove the 7/16 x 5 1/2" hex bolt (item 2) from the clutch support.
- c) Disconnect the wire from electric clutch.
- d) Remove the gas tank from the support (Put on the ground to avoid any spills).
- e) Unhook the spring (item 5) from the slot on the tension arm (item 6).
- f) Turn the snowblower face down (engine on top).
- g) Loosen the four motor mounting bolts (item 11) and nuts until the nuts are even with the end of the bolts. This will remove the tension on the v-belt.
- h) Remove the six nuts (item 3) and bolts from the reduction plate (item 4).
- i) Remove the reduction plate and the tension arm.
- j) Replace the belt.
- k) Re-install parts by repeating steps backwards.
- l) Make sure the bearing (item 12) is well centered before tightening the nuts (item 3).

Timing Belt:

- a) Remove the gas tank from the support. (Put on the ground to avoid any spills).
- b) Unhook the spring (item 5) from the slot on the tension arm (item 6).
- c) Turn the snowblower face down (engine on top).
- d) Loosen slightly the four nuts (item 7) and the two nuts (item 8) needed to apply tension to the belt.
- e) Remove the six nuts (item 3) and bolts from the reduction plate (item 4)
- f) Remove the reduction plate and the tension arm.
- g) Loosen the four motor mounting bolts (item 11) and nuts until the nuts are even with the end of the bolts. This will remove the tension on the v-belt.
- h) Remove the V-belt.
- i) Replace the timing belt.

IMPORTANT:

Make sure the notches of the belt are well inserted into the those of the pulley. See belt adjustment section.

- j) Re-install parts by repeating steps backwards.
- k) Make sure to replace and realign the V-belt on the V-pulley.
- l) Make sure the bearing (item 12) is well centered before tightening the nuts (item 3).
- m) Make sure the spring is well installed in the slot on the tension arm.

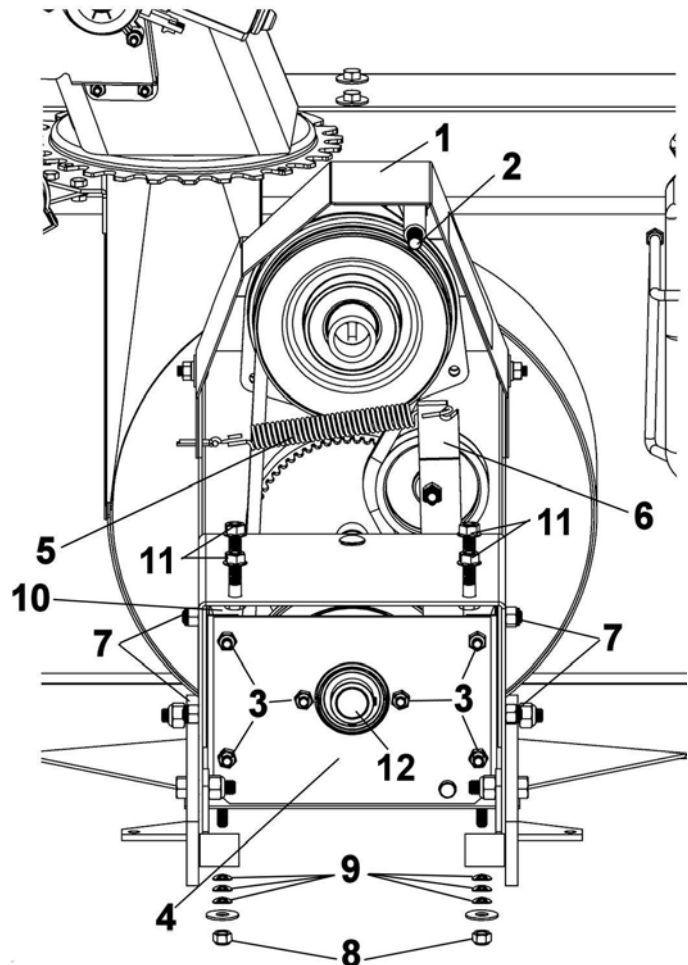

BELT ADJUSTMENTS



CAUTION



Never use the snowblower without the belt guard.

TIMING BELT ADJUSTMENT: (see following page for a good or improper pulley adjustment)

- Remove the belt guard (item 1) to better see the belt alignment
- Unhook the spring (item 5) to facilitate the rotation of the fan.
- Slightly loosen the four nuts (item 7).
- Tighten the two nuts (item 8) (needed to apply tension to the belt) until the three spring washers (item 9) are completely compressed. To have the right tension there should be a 1/32"-1/16" maximum deflection on the belt as shown.
- Retighten the four nuts (item 7).
- Turn the fan by hand a few turns and **make sure the timing belt is well engaged on the sprocket.**

If the belt is not well engaged,

- Loosen slightly the nuts (item 7) and re-align the pulleys by adjusting the angle of the reduction box (item 10) using the play of the bolt holes as shown on following page.
- Retighten the four nuts.
- Reinstall the spring (item 5) and the belt guard (item 1).

IMPORTANT: After installing the snowblower on the ATV, let snowblower run for a minute, turn everything off.

- Remove the belt guard and check the belt alignment et repeat the steps if the belt is not well aligned.
- Reinstall the belt guard.

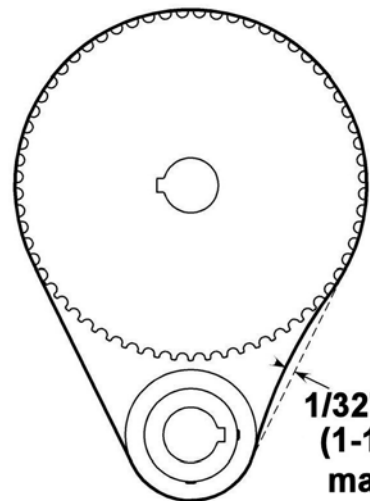
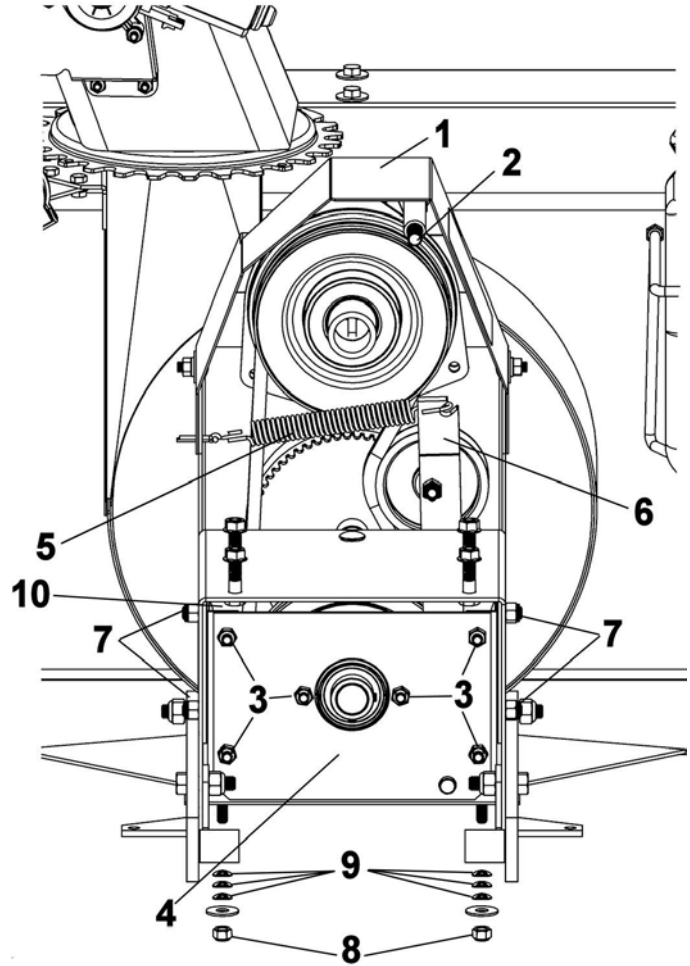

**1/32" - 1/16"
(1-1.5 mm)
maximum**

Deflection on the belt

BELT ADJUSTMENTS



CAUTION



Never use the snowblower without the belt guard.

IMPORTANT:

The following figures (side views) show a good or improper adjustment of the pulleys in the reduction box (item 10).

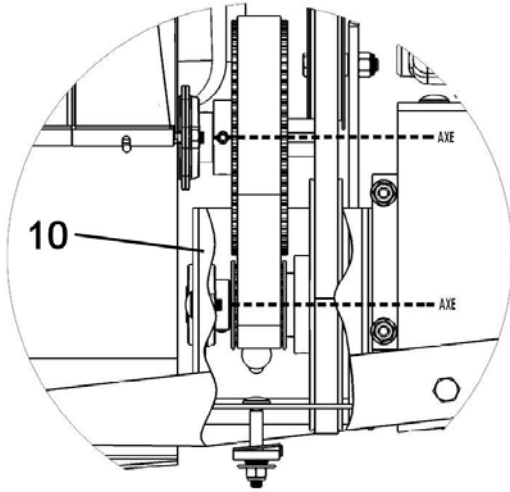

Good adjustment: The pulleys are well aligned and the timing belt stays completely engaged on the sprocket.

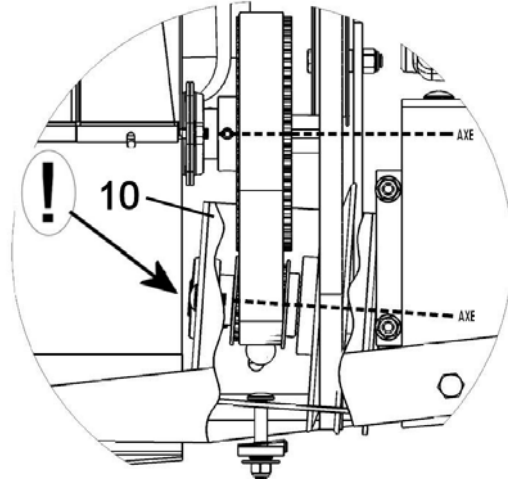

Improper adjustment: The pulleys are not well aligned and the timing belt does not stay completely engaged on the sprocket, you have to realign the pulleys by adjusting the angle of the reduction box.

REPLACEMENT OF ONE OR TWO SECTIONS OF THE AUGER AND / OR GEAR BOX

For belt part numbers, refer to snowblower parts breakdown section for parts identification

Snowblower must be detached & disconnected from the A.T.V. to replace the auger or the gear box.

- a) Remove the gas tank from the support (place on the ground to avoid any spills)
- b) Remove the belt guard (item 1).
- c) Unhook the spring (item 9) from the slot on the tension arm (item 10).
- d) Remove the 7/16 x 5 1/2" hex bolt (item 15) from the clutch support.
- e) Disconnect the wire from electric clutch.
- f) Remove the motor support (item 12) and motor by removing the bolts (item 13).
- g) Turn the snowblower face down.
- h) Remove the six nuts (item 7) and bolts from the reduction plate (item 8).
- i) Remove the reduction plate and the tension arm.
- j) Remove the four nuts on each side (item 3) and the two nuts (item 4) necessary to remove tension on the timing belt.
- k) Remove the two belts from the reduction box.
- l) Remove the reduction box (item 11).
- m) Loosen the set screws (item 2) (use heat if necessary to soften the "loctite") on the bearing and the pulley behind the snowblower.
- n) Remove the timing belt sprocket (item 5) from the gear box shaft with a puller.
- o) Remove all the bolts (item 6) and the nuts that support the gear box and its support.
- p) Remove the assembly (gear box, its support, the fan and augers) from the snowblower and save the nylon bushings and bearings.
- q) Replace the appropriate parts. Insert the shaft and the key into the new gear box (if required).
- r) Install the new auger or augers on their respective side in the position shown with the same nylon bushings on the shaft of the new gear box as shown.
- s) Re-install parts by repeating steps backwards.
- t) Make sure the bearing (item 14) is well centered before tightening the nuts (item 7).

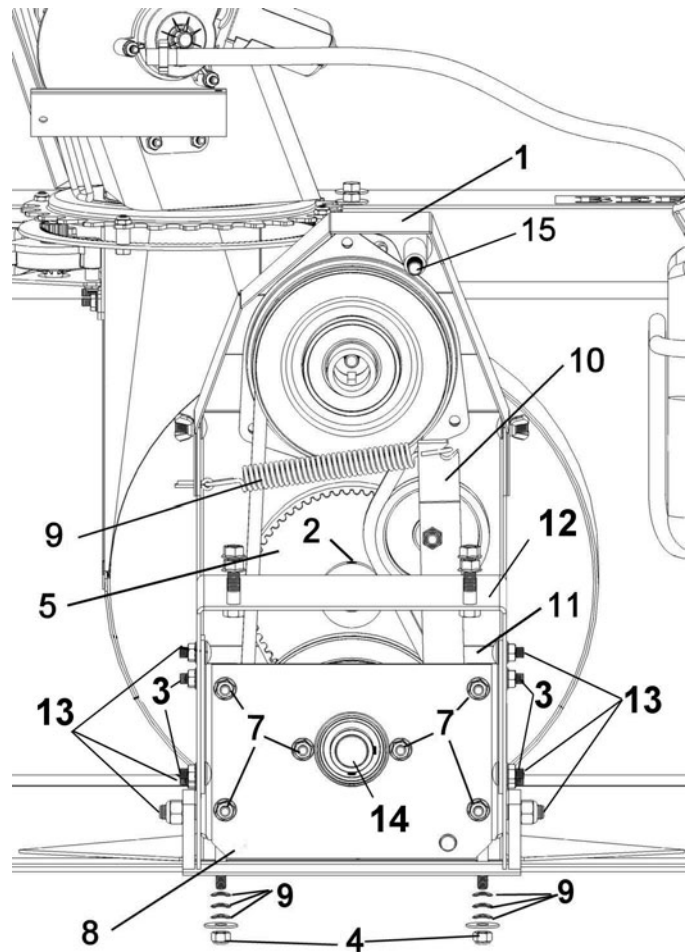

IMPORTANT: You must clean the parts and apply some "Loctite" 2760 on the key and the set screw. Tighten firmly.

Follow the instructions in the belt replacement and adjustments sections.

- u) Make sure to well reposition the timing belt sprocket and the belt behind the snowblower.

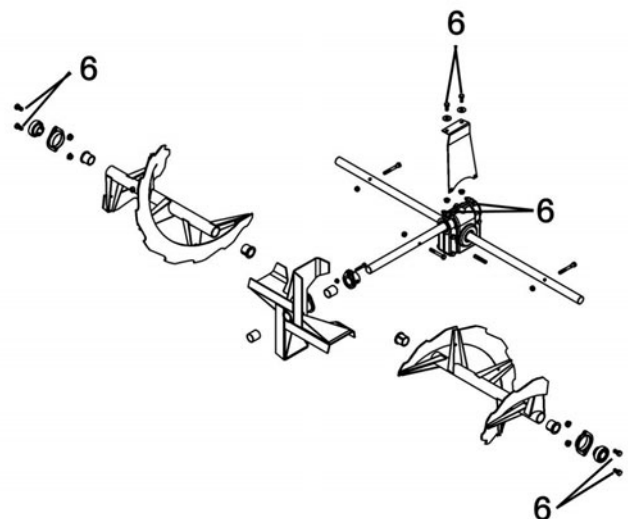

DISMOUNTING & STORAGE

DISMOUNTING THE SNOWBLOWER:

- a) Select a level surface, set parking brake, stop the engine, and remove the ignition key to prevent accidental starting.
- b) Lower the accessory to the ground.
- c) Unplug connector that unites the A.T.V. to the motor.
- d) Remove the winch hook & cable from the snowblower.
- e) Unhook the turnbuckles from the front of the vehicle, (Tip: slacken one of the turnbuckles in order to keep the adjustment), the hook from the winch and the hitch from the rear of the vehicle.
- f) Carefully back up the A.T.V. from over the subframe.

STORAGE

- a) Clean snowblower and subframe thoroughly and repaint all parts from which paint has worn.
- b) List the replacement parts that will be needed before the next season.
- c) Follow the instructions in the lubrication section
- d) Store the snowblower and the subframe in a dry place.
- e) Concerning the snowblower engine, follow the instructions in the engine owner's manual.

TROUBLESHOOTING

* Please refer to parts breakdown section for parts identification.

PROBLEM	POSSIBLE CAUSES	CORRECTIVE ACTION
Snowblower vibrates or is abnormally noisy.	Damaged pulley.	Replace pulley.
	Damaged bearing.	Replace bearing.
	Damaged fan.	Dismount & repair or replace fan.
	One or both sections of the auger is bent.	Replace one or both sections of auger.
One or both sections of the auger have stopped turning.	Shear bolt is probably broken.	Replace shear bolt (for identification, see Parts List "Snowblower"). Also see "Maintenance" section.
Snowblower stopped turning.	The belts are damaged or snapped.	Check & replace damaged belts (see instructions in section: Belt replacement & adjustments.
Belt is worn at a specific point.	Snowblower was engaged when already plugged.	Make sure auger & fan are not plugged or frozen before engaging snowblower.
Chute rotation is difficult.	Dirt or ice may be underneath chute.	Clean the base of chute & the rotation ring. Lubricate chute inside & out and the rotation worm.
	The base of the chute may be damaged or bent.	Replace defective parts.
The chute plugs easily.	Snowblower engine is turning too slowly.	Always have engine at full R.P.M. when using the snowblower.
	Advancing too quickly with A.T.V.	Reduce speed. Allow snowblower to ingest snow at its own speed.
Snowblower digs into ground.	Ground is not frozen or too soft.	Adjust skid shoes lower so they may better support the snowblower.
Snowblower does not raise evenly.	Uneven tire pressure from one side to another.	Verify and adjust snowblower tire pressure: 50 p.s.i.
Electric motor does not work.	Overheating of the motor.	These motors are equipped with an internal protector. Wait 10 minutes before using.

TORQUE SPECIFICATION TABLE

GENERAL TORQUE SPECIFICATION TABLE USE THE FOLLOWING TORQUES WHEN SPECIAL TORQUES ARE NOT GIVEN

NOTE: These values apply to fasteners as received from supplier, dry or when lubricated with normal oil. They do not apply if special graphited or moly disulphide greases or other extreme pressure lubricants are used. This applies to both UNF and UNC threads.

* Thick nuts must be used with grade 8 bolts

SEE Grade No.		2				5				8 *			
BOLT HEAD IDENTIFICATION MARKS AS PER GRADE NOTE MANUFACTURING MARKS WILL VARY		TORQUE				TORQUE				TORQUE			
BOLT SIZE		FOOT POUNDS		NEW TON-METERS		FOOT POUNDS		NEW TON-METERS		FOOT POUNDS		NEW TON-METERS	
Inches	Millimetre	Min.	Max.	Min.	Max.	Min.	Max.	Min.	Max.	Min.	Max.	Min.	Max.
1/4"	6.35	5	6	6.8	8.13	9	11	12.2	14.9	12	15	16.3	30.3
5/16"	7.94	10	12	13.6	16.3	17	20.5	23.1	27.8	24	29	32.5	39.3
3/8"	9.53	20	23	27.1	31.2	35	42	47.5	57	45	54	61	73.2
7/16"	11.11	30	35	40.7	47.4	54	64	73.2	86.8	70	84	94.9	113.9
1/2"	12.7	45	52	61	70.5	80	96	108.5	130.2	110	132	149.2	179
9/16"	14.29	65	75	88.1	101.6	110	132	149.2	179	160	192	217	260.4
5/8"	15.88	95	105	128.7	142.3	150	180	203.4	244.1	220	264	298.3	358
3/4"	19.05	150	185	203.3	250.7	270	324	366.1	439.3	380	456	515.3	618.3
7/8"	22.23	160	200	216.8	271	400	480	542.4	650.9	600	720	813.6	976.3
1"	25.4	250	300	338.8	406.5	580	696	786.5	943.8	900	1080	1220.4	1464.5

METRIC BOLT TORQUE SPECIFICATIONS							
		COARSE THREAD			FINE THREAD		
Size Screw	Grade No.	Pitch (mm)	Foot Pounds	Newton-Meters	Pitch (mm)	Foot Pounds	Newton-Meters
M6	4T	1.00	3.6 - 5.8	4.9 - 7.9	-	-	-
	7T		5.8 - 9.4	7.9 - 12.7		-	-
	8T		7.2 - 10	9.8 - 13.6		-	-
M8	4T	1.25	7.2 - 14	9.8 - 19	1.00	12 - 17	16.3 - 23
	7T		17 - 22	23 - 29.8		19 - 27	25.7 - 36.6
	8T		20 - 26	27.1 - 35.2		22 - 31	29.8 - 42
M10	4T	1.50	20 - 25	27.1 - 33.9	1.25	20 - 29	27.1 - 39.3
	7T		34 - 40	46.1 - 54.2		35 - 47	47.4 - 63.7
	8T		38 - 46	51.5 - 62.3		40 - 52	54.2 - 70.5
M12	4T	1.75	28 - 34	37.9 - 46.1	1.25	31 - 41	42 - 55.6
	7T		51 - 59	69.1 - 79.9		56 - 68	75.9 - 92.1
	8T		57 - 66	77.2 - 89.4		62 - 75	84 - 101.6
M14	4T	2.00	49 - 56	66.4 - 75.9	1.50	52 - 64	70.5 - 86.7
	7T		81 - 93	109.8 - 126		90 - 106	122 - 143.6
	8T		96 - 109	130.1 - 147.7		107 - 124	145 - 168
M16	4T	2.00	67 - 77	90.8 - 104.3	1.50	69 - 83	93.5 - 112.5
	7T		116 - 130	157.2 - 176.2		120 - 138	162.6 - 187
	8T		129 - 145	174.8 - 196.5		140 - 158	189.7 - 214.1
M18	4T	2.00	88 - 100	119.2 - 136	1.50	100 - 117	136 - 158.5
	7T		150 - 168	203.3 - 227.6		177 - 199	239.8 - 269.6
	8T		175 - 194	237.1 - 262.9		202 - 231	273.7 - 313
M20	4T	2.50	108 - 130	146.3 - 176.2	1.50	132 - 150	178.9 - 203.3
	7T		186 - 205	252 - 277.8		206 - 242	279.1 - 327.9
	8T		213 - 249	288.6 - 337.4		246 - 289	333.3 - 391.6

PARTS BREAKDOWN ROTATION SYSTEM WITH CHUTE

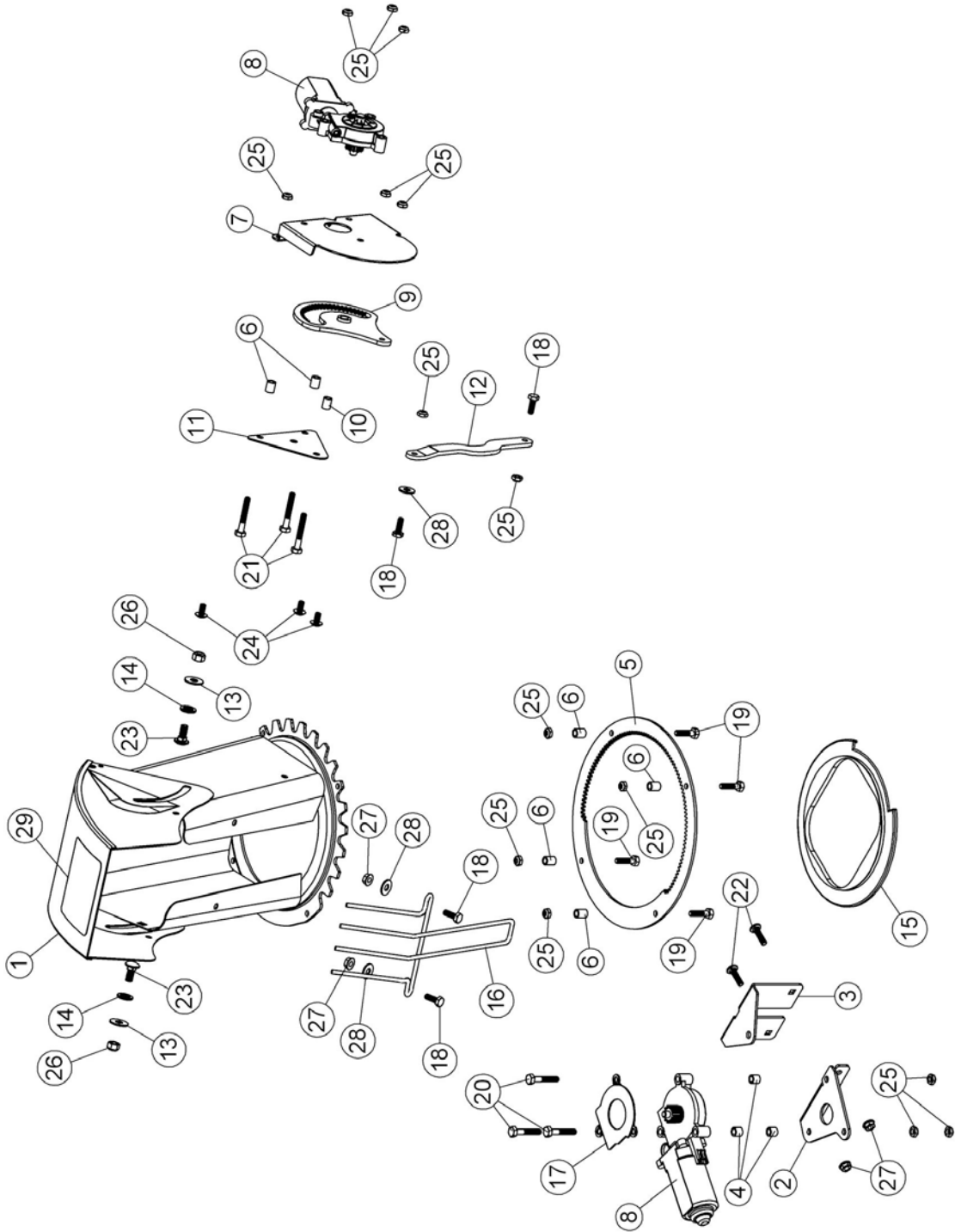

PARTS LIST ROTATION SYSTEM WITH CHUTE

Ref. Réf.	English description	Description française	Qty. Qté.	Part # Pièce #
1	Chute	Goulotte	1	103936
2	Bracket	Support	1	103971
3	Reinforcement plate	Plaque de renforcement	1	103972
4	Spacer	Espaceur	3	103368
5	Rotation ring	Anneau de rotation	1	103974
6	Spacer	Espaceur	6	103361
7	Bracket	Support	1	103375
8	Electric motor	Moteur électrique	2	103378
9	Lever	Levier	1	103365
10	Oil lite bushing	Coussinet imprégné d'huile	1	103362
11	Plate	Plaque	1	103363
12	Arm	Bras	1	103364
13	Nylon flat washer 11/32"	Rondelle plate de nylon 11/32"	2	102009
14	Nylon flat washer 7/16"	Rondelle plate de nylon 7/16"	2	102011
15	Rotation ring	Anneau de rotation	1	103943
16	Hand guard	Fourche protectrice	1	102012
17	Protective plate	Plaque protectrice	1	105404
18	Hex. bolt 1/4" n.c. x 3/4"	Boulon hex. 1/4" n.c. x 3/4"	4	O/L
19	Hex. bolt 1/4" n.c. x 1"	Boulon hex. 1/4" n.c. x 1"	4	O/L
20	Hex. bolt 1/4" n.c. x 1 1/2"	Boulon hex. 1/4" n.c. x 1 1/2"	3	O/L
21	Hex. bolt 1/4" n.c. x 1 3/4"	Boulon hex. 1/4" n.c. x 1 3/4"	3	O/L
22	Carriage bolt 1/4" n.c. x 1"	Boulon à carrosserie 1/4" n.c. x 1"	2	O/L
23	Carriage bolt 5/16" n.c. x 3/4"	Boulon à carrosserie 5/16" n.c. x 3/4"	2	O/L
24	Machine screw T.H. 1/4" n.c. x 1/2"	Vis mécanique T.H. 1/4" n.c. x 1/2"	3	O/L
25	Nylon insert lock nut 1/4" n.c. (thin)	Écrou à garniture de nylon 1/4" n.c.(mince)	15	O/L
26	Nylon insert lock nut 5/16" n.c.	Écrou à garniture de nylon 5/16" n.c.	2	O/L
27	Flange nut 1/4" n.c.	Écrou à bride 1/4" n.c.	4	O/L
28	Flat washer 5/16" hole	Rondelle plate 5/16" trou	3	O/L
29	Danger decal chute	Décalque danger goulotte	1	105127

O/L = Obtain Locally

PARTS BREAKDOWN SADDLE ASSEMBLY

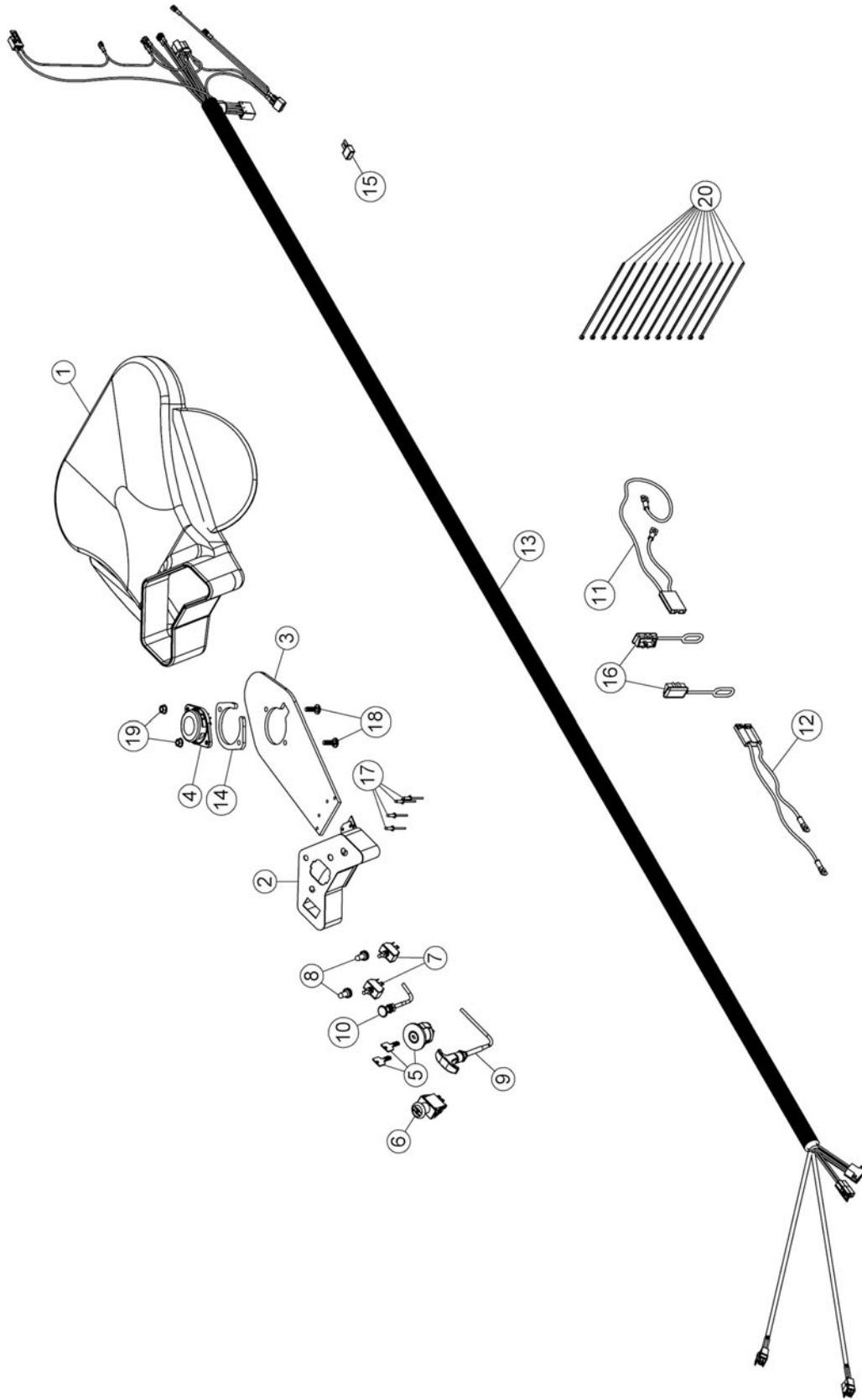

PARTS LIST SADDLE ASSEMBLY

Ref. Réf.	English description	Description française	Qty. Qté.	Part # Pièce #
1	Seat cover	Couvre-siège	1	103987
2	Control board	Tableau de contrôle	1	104011
3	Switch support	Support de commutateur	1	104012
4	Safety switch ass'y	Commutateur de sécurité ass'é	1	104014
5	Ignition switch	Commutateur d'ignition	1	104015
6	P.T.O. switch	Commutateur de p.d.f.	1	104016
7	Switch	Commutateur	2	103381
8	Rubber boot	Capuchon de caoutchouc	2	103379
9	Throttle control	Contrôle de l' accélérateur	1	104008
10	Choke control	Contrôle de l' étrangleur	1	104009
11	Wire assembly	Fil assemblé	1	104017
12	Wire assembly	Fil assemblé	1	104018
13	Wire assembly (Incl. 103382)	Fils assemblés (Incl. 103382)	1	104295
14	Shim	Cale	1	104013
15	Breaker	Disjoncteur	1	103382
16	Cap	Capuchon	2	105407
17	Pop-rivet 3/16" no AD-66BS	Rivet pop 3/16 no.AD-66BS	4	O/L
18	Carriage bolt 5/16" n.c. x 1"	Boulon à carrosserie 5/16" n.c. x 1"	2	O/L
19	Flange nut 5/16" n.c.	Écrou à bride 5/16" n.c.	2	O/L
20	Tie wrap 8"	Attache de nylon 8"	12	O/L

O/L = Obtain Locally

PARTS BREAKDOWN SUBFRAME

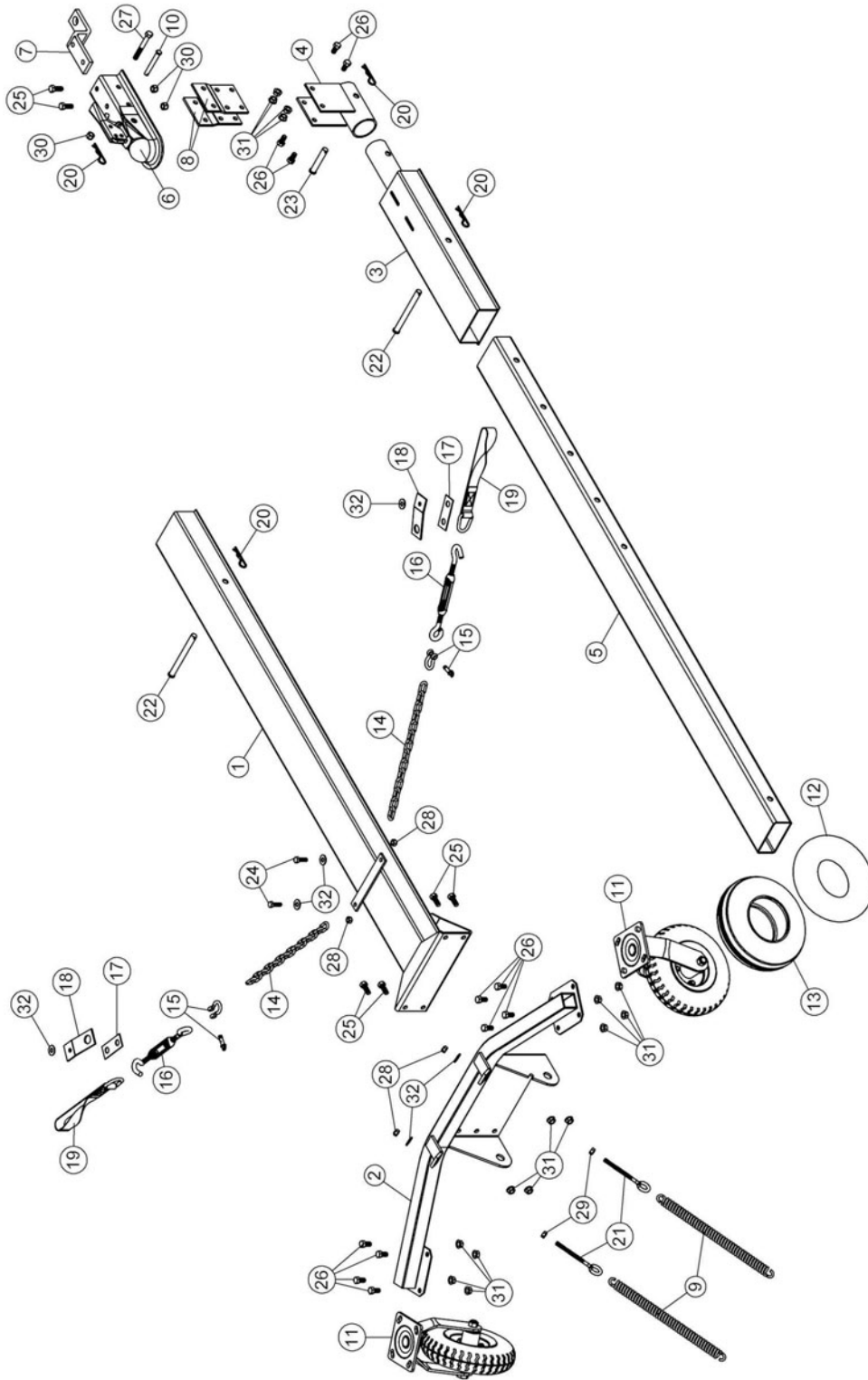

PARTS LIST SUBFRAME

Ref. Réf.	English description	Description française	Qty. Qté.	Part # Pièce #
1	Subframe	Sous-châssis	1	104957
2	Wheel support	Support de roue	1	104901
3	Rear bracket	Fixation arrière	1	104956
4	Hitch support	Support d'attache	1	104958
5	Adjustment tube	Tube d'ajustement	1	104959
6	Hitch	Attache	1	104639
7	Hitch ball support	Support de boule d'attelage	1	104640
8	Hitch support plate	Plaque de support d'attache	2	104641
9	Spring	Ressort	2	103073
10	Pin	Goupille	1	104642
11	Caster wheel assembly	Roue pivotante assemblée	2	105679
12	Inner tube 250-4	Chambre à air 250-4	1	102675
13	Tire 280/250-4	Pneu 280/250-4	1	102674
14	Chain	Chaîne	2	104633
15	Shackle Ptd Z	Clevis Pqé Z	2	102343
16	Turnbuckle	Tendeur	2	104634
17	Bracket	Fixation	2	104632
18	Bracket	Fixation	2	105194
19	Lift strap	Sangle de relevage	2	103613
20	Hair pin 3mm	Goupille à ressort 3mm	4	102617
21	Eye bolt	Boulon à oeillet	2	102087
22	Pin	Goupille	2	104961
23	Pin	Goupille	1	104999
24	Hex. bolt 5/16" n.c. x 1"	Boulon hex. 5/16" n.c. x 1"	2	O/L
25	Hex. bolt 3/8" n.c. x 1"	Boulon hex. 3/8" n.c. x 1"	6	O/L
26	Hex. bolt 3/8" n.c. x 3/4"	Boulon hex. 3/8" n.c. x 3/4"	12	O/L
27	Hex. bolt 3/8" n.c. x 3"	Boulon hex. 3/8" n.c. x 3"	1	O/L
28	Nylon insert lock nut 5/16" n.c.	Écrou à garniture de nylon 5/16" n.c.	4	O/L
29	Hex. nut 5/16" n.c.	Écrou hex. 5/16" n.c.	2	O/L
30	Nylon insert lock nut 3/8" n.c.	Écrou à garniture de nylon 3/8" n.c.	3	O/L
31	Flange nut 3/8" n.c.	Écrou à bride 3/8" n.c.	16	O/L
32	Flat washer 3/8" hole	Rondelle plate 3/8" trou	6	O/L

O/L = Obtain Locally

PARTS BREAKDOWN SNOWBLOWER

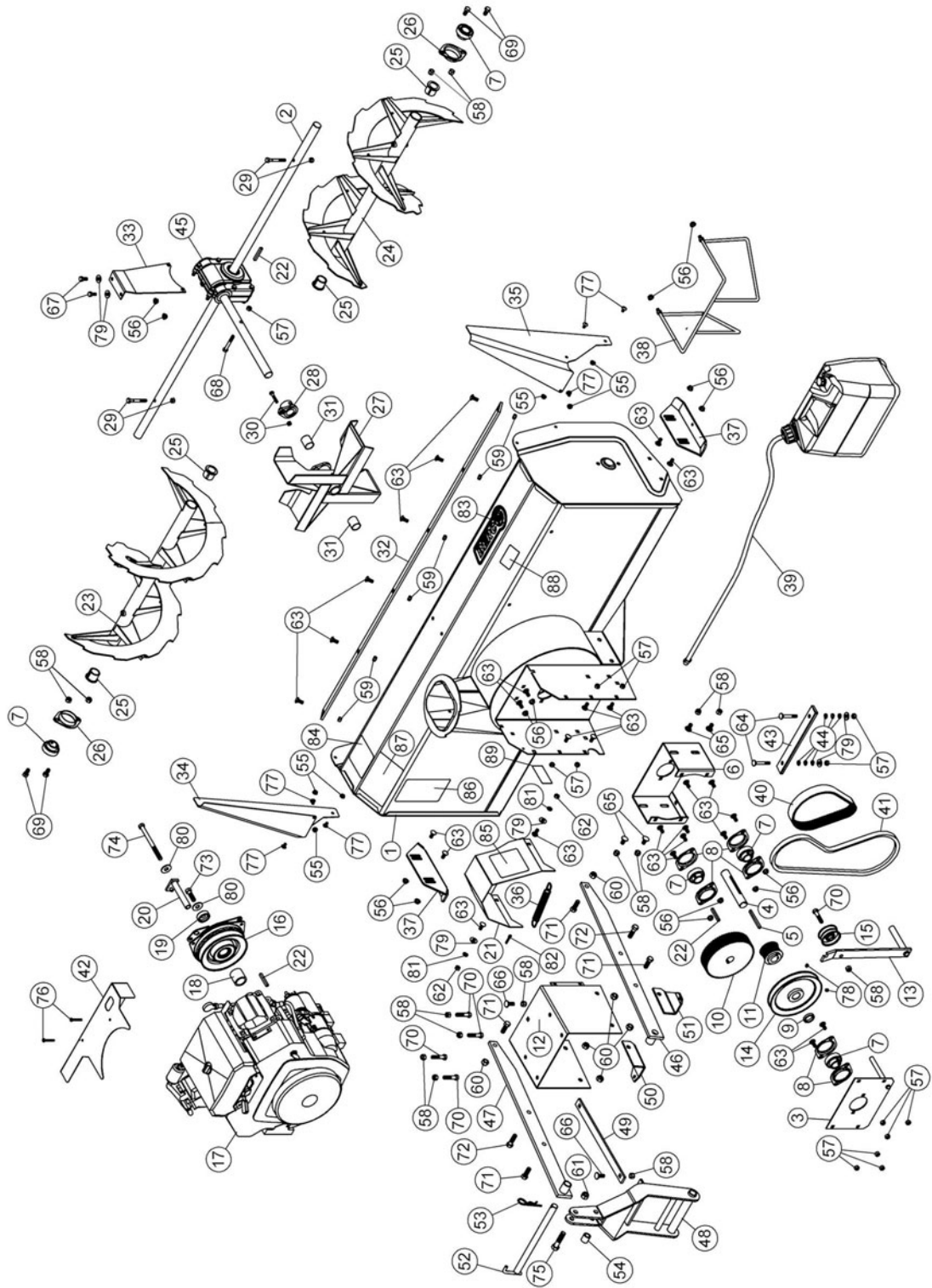

PARTS LIST SNOWBLOWER

Ref. Réf.	English description	Description française	Qty. Qté.	Part # Pièce #
1	Frame 54"	Châssis 54"	1	104896
2	Shaft 54"	Arbre 54"	1	104722
3	Reduction plate	Plaque de réduction	1	103959
4	Shaft	Arbre	1	103961
5	Key 1/4" x 1/4" x 2 31/32	Clé 1/4" x 1/4" x 2 31/32	1	103962
6	Reduction box	Boîte de réduction	1	103960
7	Bearing with set screw	Roulement à billes avec vis à pression	5	102755
8	Flangette	Flangette	6	102213
9	Spacer	Douille d'espacement	1	103997
10	Sprocket with set screw	Pignon avec vis à pression	1	103743
11	Sprocket with set screw	Pignon avec vis à pression	1	103741
12	Engine support	Support de moteur	1	103970
13	Tension arm	Bras de tension	1	103985
14	V pulley	Poulie en V	1	103739
15	Flat pulley	Poulie plate	1	102057
16	Electric clutch	Embrayage électrique	1	103998
17	Engine CH-23 (Kohler)	Moteur CH-23 (Kohler)	1	104003
18	Clutch spacer	Espaceur d'embrayage	1	103975
19	Flange washer	Rondelle à bride	1	103976
20	Clutch support	Support d'embrayage	1	103980
21	Belt guard	Garde-courroie	1	103979
22	Key 1/4" x 1/4" x 2"	Clé 1/4" x 1/4" x 2"	3	102922
23	Auger 54" left	Vis 54" gauche	1	104747
24	Auger 54" right	Vis 54" droite	1	104748
25	Rotation bushing	Coussinet de rotation	4	103946
26	Flangette	Flangette	2	102680
27	Fan	Éventail	1	103932
28	Shear plate	Plaque de cisaillement	1	103933
29	Shear bolt / N.I.L.N. (auger) pkg-10	Boulon de séc. / É.G.N. (vis) pqt-10	2	104000
30	Shear bolt / N.I.L.N. (fan) pkg-10	Boulon de séc./ É.G.N. (éven.) pqt-10	1	103999

O/L = Obtain Locally

PARTS LIST SNOWBLOWER

Ref. Réf.	English description	Description française	Qty. Qté.	Part # Pièce #
31	Oil lite bushing	Coussinet imprégné d'huile	2	102784
32	Cutting edge 54"	Racloir 54"	1	104427
33	Gear box support	Support de boîte d'engrenage	1	104746
34	Left drift cutter	Couteau à neige gauche	1	102821
35	Right drift cutter	Couteau à neige droit	1	102822
36	Spring	Ressort	1	102304
37	Skid shoe	Patin	2	103188
38	Tank support	Support de réservoir	1	104792
39	Gasoline tank assembly	Réservoir d'essence assemblé	1	104005
40	Timing belt 600-8MT-30	Courroie synchronisée 600-8MT-30	1	104004
41	V-Belt , MXV5-420	Courroie en V , MXV5-420	1	105669
42	Heat shield	Pare-chaleur	1	104621
43	Tension bar	Barre de tension	1	103995
44	Spring washer	Rondelle à ressort	6	104007
45	Gear box left rotation	Boîte d'engrenage rotation gauche	1	104718
46	Right hitch	Attache droite	1	104897
47	Left hitch	Attache gauche	1	104898
48	Lever	Levier	1	104899
49	Link	Lien	1	104900
50	Left spring link	Lien du ressort gauche	1	103977
51	Right spring link	Lien du ressort droit	1	103978
52	Pin	Goupille	1	104759
53	Hair pin 4mm	Goupille à ressort 4mm	1	102054
54	Sleeve	Douille	1	102480
55	Flange nut 1/4" n.c.	Écrou à bride 1/4" n.c.	6	O/L
56	Flange nut 5/16" n.c.	Écrou à bride 5/16" n.c.	14	O/L
57	Nylon insert lock nut 5/16" n.c.	Écrou à garniture de nylon 5/16" n.c.	13	O/L
58	Nylon insert lock nut 3/8" n.c.	Écrou à garniture de nylon 3/8" n.c.	15	O/L
59	Stover lock nut 5/16" n.c.	Écrou de blocage 5/16" n.c.	6	O/L
60	Nylon insert lock nut 7/16" n.c.	Écrou à garniture de nylon 7/16" n.c.	6	O/L

O/L = Obtain Locally

PARTS LIST SNOWBLOWER

Ref. Réf.	English description	Description française	Qty. Qté.	Part # Pièce #
61	Nylon Insert lock Nut 1/2" n.c.	Écrou à garniture de nylon 1/2" n.c.	1	O/L
62	Hex. nut 5/16" n.c.	Écrou hex. 5/16" n.c.	2	O/L
63	Carriage bolt 5/16" n.c. x 3/4"	Boulon à carrosserie 5/16" n.c. x 3/4"	28	O/L
64	Carriage bolt 5/16" n.c. x 2 1/4"	Boulon à carrosserie 5/16" n.c. x 2 1/4"	2	O/L
65	Carriage bolt 3/8" n.c. x 3/4"	Boulon à carrosserie 3/8" n.c. x 3/4"	4	O/L
66	Carriage bolt 3/8" n.c. x 1"	Boulon à carrosserie 3/8" n.c. x 1"	2	O/L
67	Hex. bolt 5/16" n.c. x 3/4"	Boulon hex. 5/16" n.c. x 3/4"	2	O/L
68	Hex. bolt 5/16" n.c. x 2 1/4" GR8	Boulon hex. 5/16" n.c. x 2 1/4" GR8	1	O/L
69	Hex. bolt 3/8" n.c. x 3/4"	Boulon hex. 3/8" n.c. x 3/4"	4	O/L
70	Hex. bolt 3/8" n.c. x 1 3/4"	Boulon hex. 3/8" n.c. x 1 3/4"	5	O/L
71	Hex. bolt 7/16" n.c. x 1 1/4"	Boulon hex. 7/16" n.c. x 1 1/4"	4	O/L
72	Hex. bolt 7/16" n.c. x 1 1/2"	Boulon hex. 7/16" n.c. x 1 1/2"	2	O/L
73	Hex. bolt 7/16" n.f. x 1 1/2"	Boulon hex. 7/16" n.f. x 1 1/2"	1	O/L
74	Hex. bolt 7/16" n.c. x 5 1/2"	Boulon hex. 7/16" n.c. x 5 1/2"	1	O/L
75	Hex. bolt 1/2" n.c. x 2 1/4"	Boulon hex. 1/2" n.c. x 2 1/4"	1	O/L
76	Machine screw P.H. #10 x 32 x 1 1/2"	Vis mécanique P.H. #10 x 32 x 1 1/2"	2	O/L
77	Machine screw T.H. 1/4" n.c. x 1/2"	Vis mécanique T.H. 1/4" n.c. x 1/2"	6	O/L
78	Hex. socket set screw 5/16" n.c. x 5/16"	Vis à pression hex. 5/16" n.c. x 5/16"	2	O/L
79	Flat washer 3/8" hole	Rondelle plate 3/8" trou	6	O/L
80	Flat washer 1/2" hole	Rondelle plate 1/2" trou	2	O/L
81	Lock washer 5/16"	Rondelle de blocage 5/16"	2	O/L
82	Cotter pin 3/16" x 1"	Goupille fendue 3/16" x 1"	1	O/L
83	Berco decal	Décalque Berco	1	102471
84	Decal danger auger	Decalque danger vis	1	105126
85	Decal danger belts	Decalque danger courroies	1	105128
86	Decal read instructions	Decalque lire instructions	1	105130
87	Decal warning safety	Decalque avertissement sécurité	1	105131
88	Specifications decal	Décalque spécifications	1	REF
89	Serial number	Numéro de série	1	REF

O/L = Obtain Locally

OPTIONS

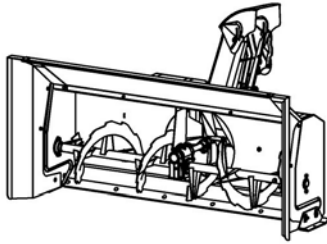

**EXTENSION AND SIDE WIDENING
ANGLE KIT
#700461 .**
Widens the snowblower by 6'' and
adds about 7'' to the height.

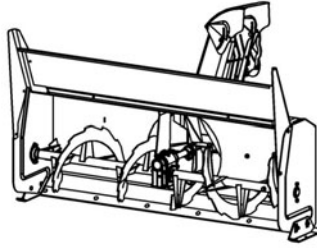

**EXTENSION PANEL
#700473**
Adds about 10'' to the height of the
snowblower

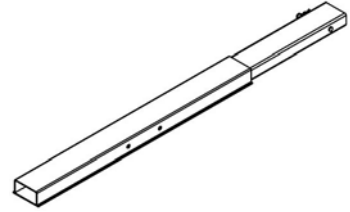

**SUBFRAME EXTENSION
#700485**
For bigger vehicle



***WHEN PERFORMANCE
& DEPENDABILITY
ARE NON NEGOTIABLE!***

Bercomac Limitée
92, Fortin North, Adstock, Quebec, Canada, G0N 1S0

WWW.BERCOMAC.COM

PRINTED IN CANADA

(ORIGINAL NOTICE)