



OWNER'S MANUAL

Model number

700380-1 (Nylon brush)

700381-1 (Polypropylene brush)



BERCO

Rotary Broom

for

LAWN, YARD, & GARDEN TRACTORS

BELT OR SHAFT DRIVE P.T.O.

* ASSEMBLY

* REPAIR PARTS

* OPERATION

* MAINTENANCE

CAUTION:

**READ & FOLLOW ALL SAFETY RULES & INSTRUCTIONS
BEFORE OPERATING YOUR EQUIPMENT**

LIMITED WARRANTY

Conditions and Products Covered:

BERCOMAC guarantees any part of the product or accessory manufactured by BERCOMAC and found in the reasonable judgment of BERCOMAC to be defective in material and or workmanship will be repaired or replaced by an authorized dealer without charge up to our maximum labor rates and pre-established times. For replacement parts only standard ground freight services are covered. This warranty extends to the original retail purchaser only and is not transferable to any subsequent purchasers.

Warranty Period

(from date of the original retail purchase):

- Residential use: 1 year
- Commercial or rental use: 90 days

Exceptions Noted Below: the following items are guaranteed by the original manufacturer and have their own warranty, conditions and limited time:

- Tire Chains: 90 days
- Engines (supplied with BERCOMAC equipment): 2 years

Please refer to the engine manufacturer's warranty statement included with the unit. BERCOMAC is not authorized to handle warranty adjustments on engines.

Items and Conditions NOT Covered:

This warranty does not cover the following:

- Pick-up or delivery charges or in-home services fees.
- Any damage or deterioration of the unit, parts and or finish of these due to normal use, wear and tear, or exposure.
- Cost of regular use or maintenance service or parts, such as gas, oil, lubricants, tune-up parts, and adjustments.
- Any part or accessory which has been altered, modified, misused, neglected, accidentally damaged or not properly installed, maintained, stored or repaired not in accordance with the instructions in the owner's manual.
- Repair due to normal wear and or any wear items such as shear pins, bolts, belts, etc.
- Expedited freight fee services for replacement parts.
- Shear bolts and shear pins are to be considered as a preventive measure not as an assured protection, any damages resulting from the lack of shear bolts breakage are not covered.

NOTE: All warranty work must be performed by an authorized dealer using original (manufacturer) replacement parts.

Note: Bercomac reserves the right to change or improve the design of any part or accessory without assuming any obligation to modify any product previously manufactured.

Instructions for Obtaining Warranty Services:

Contact dealer where equipment was purchased or any other BERCOMAC Service Dealer to arrange service at their dealership. To locate a dealer convenient to you, access our website at www.bercomac.com. Bring the product and your proof of purchase (sales receipt) to the BERCOMAC dealer.

Owner's Responsibilities:

BERCOMAC's defective equipment or part must be returned to an authorized dealer within the warranty period for repairs. In the event that defective merchandise must be returned to manufacturer for repairs, freight fees are prepaid and a written authorization from BERCOMAC must be obtained by dealer prior to the shipment. This warranty extends only to equipment operated under normal conditions. To validate a warranty claim, it is the user's responsibility to maintain and service the unit as specified in the owner's manual at their expense.

General Conditions:

The sole liability of BERCOMAC with respect to this warranty shall be strictly and exclusively repair and replacement as mentioned herein. BERCOMAC shall not have any liability for any other costs, loss or damage, including but not limited to, any incidental or consequential loss or damage.

In particular, without being limited to, BERCOMAC shall have no liability or responsibility for:

- Travel time, overtime, after hours time or other extraordinary repair charges or relating to repairs and or replacements outside of normal business hours.
- Rental of like or similar replacement equipment during the period of any, repair or replacement work.
- Any communicating or travel charges.
- Loss or damage to person or property other than that covered by the terms of this warranty.
- Any claims for lost revenue, lost profit or any similar costs as a result of damage or repair.
- Attorney's fees.

BERCOMAC's responsibility in respect to claims is limited to making the required repairs or replacement without charge up to our maximum labor rates and pre-established times and no claim of breach of warranty shall be cause for cancellation or rescission of the contract of sale of any product or accessory.

This warranty gives you specific legal rights. You may also have other rights, which vary from state to state.

TABLE OF CONTENTS

	PAGE
INTRODUCTION	2
SAFETY PRECAUTIONS	3
SAFETY DECALS	5
ASSEMBLY	
Step 1: Rotary Broom Preparation	6
Step 2: Rotary Broom Installation	7
*See Adaptor Mounting Instructions and Subframe Mounting Instructions (Included with products)	
OPERATION	
Rotary Broom Angle Adjustment	9
Pressure on the Brush Adjustment	9
General Sweeping	9
Snow Sweeping	9
Lawn Dethatching and Leaf Raking	9
MAINTENANCE & DISMOUNTING	
Maintenance	10
Brush Replacement	10
Dismounting	10
End of Season Storage	10
TROUBLESHOOTING	11
PARTS BREAKDOWN AND LISTS	
Rotary Broom	12
TORQUE SPECIFICATION TABLE	16
ATTACHMENTS	17

INTRODUCTION

TO THE PURCHASER

This new attachment was carefully designed to give years of dependable service. This manual has been provided to assist in the safe operation and servicing of your attachment.

NOTE: All photographs and illustrations in the manual may not necessarily depict the actual models or attachment, but are intended for reference only and are based on the latest product information available at the time of publication.

Familiarize yourself fully with the safety recommendations and operating procedures before putting the machine to use. Carefully read, understand and follow these recommendations and insist that they be followed by those who will use this attachment.



THIS SAFETY ALERT SYMBOL IDENTIFIES AN IMPORTANT SAFETY MESSAGE IN THIS MANUAL THAT HELPS YOU AND OTHERS AVOID PERSONAL INJURY OR EVEN DEATH. DANGER, WARNING, AND CAUTION ARE SIGNAL WORDS USED TO IDENTIFY THE LEVEL OF HAZARD. HOWEVER, REGARDLESS OF THE HAZARD, BE EXTREMELY CAREFUL.

DANGER: Signals an extreme hazard that will cause serious injury or death if recommended precautions are not followed.

WARNING: Signals a hazard that may cause serious injury or death if the recommended precautions are not followed.

CAUTION: Signals a hazard that may cause minor or moderate injury if the recommended precautions are not followed.

Record your attachment serial number and purchase date in the section reserved below (there is no serial number on the subframe or adaptor). Your dealer requires this information to give you prompt, efficient service when ordering replacement parts. Use only genuine parts when replacements are required.

If warranty repairs are required please present this registration booklet and original sales invoice to your selling dealer for warranty service.

This manual should be kept for future reference.

Please check if you have received all the parts for your kit with the list of the bag and the list of the box.

SERIAL NUMBER : _____

PURCHASE DATE : _____

In this manual, right and left sides are determined by sitting on the tractor seat facing forward.

SAFETY PRECAUTIONS

Careful operation is your best insurance against an accident. Read this section carefully before operating the tractor and the rotary broom. All operators, no matter how experienced they may be, should read this and other manuals related to the tractor and rotary broom before operating. It is the owner's legal obligation to instruct all operators in how to safely operate the rotary broom.

TRAINING



This symbol, "Safety Alert Symbol", is used throughout this manual and on the attachment's safety labels to warn of the possibility of serious injury. Please take special care in reading and understanding the safety precautions before operating the tractor or the rotary broom.

1. Read this owner's manual carefully. Be thoroughly familiar with the controls and proper use of the rotary broom. Know how to stop the unit and disengage the controls quickly.
2. Never allow children to operate the tractor nor the rotary broom. Never allow adults to operate the tractor nor the rotary broom without proper instructions.
3. No one should operate the tractor nor the rotary broom while intoxicated or while taking medication that impairs the senses or reactions.
4. Keep the area of operation clear of all persons, particularly small children and pets.
- e) When practical, remove gas-powered equipment from the truck or trailer and refuel it on the ground. If this is not possible, then refuel such equipment on a trailer with a portable container, rather than from a gasoline dispenser nozzle.
- f) Keep the nozzle in contact with the rim of the fuel tank or container opening at all times, until refuelling is complete. Do not use a nozzle lock-open device.
- g) Replace fuel cap securely and wipe up spilled fuel.
- h) If fuel is spilled on clothing, change clothing immediately.
4. Never attempt to make any adjustments while the engine (motor) is running (except when specifically recommended by manufacturer).
5. Always wear safety glasses or eye shields during operation or while performing an adjustment or repair to protect eyes from foreign objects that may be thrown from the rotary broom.
6. **Never modify the rotary broom or any part without the written consent from the manufacturer.**

PREPARATION

1. Thoroughly inspect the area where the rotary broom is to be used and remove door mats, all foreign objects and the like.
2. Disengage all clutches and shift into neutral before starting engine.
3. Do not operate the rotary broom without wearing adequate outer garments. Avoid loose fitting clothing that can get caught in moving parts. Wear footwear that will improve footing on slippery surfaces.
4. Handle fuel with care, it is highly flammable.
 - a) Use approved fuel container.
 - b) Never add fuel to a running engine or hot engine.
 - c) Fill fuel tank outdoors with extreme care. Never fill fuel tank indoors.
 - d) Never fill containers inside a vehicle, or on a truck or a trailer bed with a plastic liner. Always place containers on the ground, away from your vehicle, before filling.

OPERATION

1. Do not put hands or feet near or under rotating parts.
2. Exercise extreme caution when operating on or crossing gravel drives, walks, or roads. Stay alert for hidden hazards or traffic. Do not carry passengers.
3. After striking a foreign object, stop the engine (motor), disconnect the wire from the spark plug(s) and keep wire away to prevent accidental starting. Thoroughly inspect the rotary broom for any damage and repair damage before using.
4. If the unit should start to vibrate abnormally, stop the engine (motor) and check immediately for the cause. Vibration is generally a warning of trouble.

SAFETY PRECAUTIONS

5. Take all possible precautions when leaving the machine unattended. Disengage the power take-off, lower the attachment, set the parking brake, stop the engine and remove the key.
6. When cleaning, repairing or inspecting the rotary broom, make certain that all moving parts have stopped. Disconnect wire from the spark plug(s) and keep wire away to prevent accidental starting.
7. Do not run the engine indoors, except when starting the engine and for transporting in or out of the building. Do not operate or let motor run in a storage area without ventilation because gas contains carbon monoxide which is odorless, colorless and can cause death.
8. Never sweep across the face of slopes. Exercise extreme caution when changing direction on slopes. Do not attempt to clear a steep slope.
9. Never operate the rotary broom without proper guards, plates, or other safety protective devices in place
10. Never tolerate bystanders in the working zone. Never sweep in the direction of bystanders, the brush might throw gravel or debris that can break or damage property.
11. To sweep snow, use tire chains approved by the manufacturer. You must use 100 lbs. of rear counterweight for better traction and a greater stability at all times when using a rotary broom that is installed on the front of a tractor.
12. Never operate the rotary broom at high transport speeds on slippery surfaces. Use care when backing.
13. Do not carry passengers.
14. Disengage power to rotary broom when it is transported or not in use
15. Never operate the rotary broom without good visibility or light.
16. Keep the brush away from heat sources or flames.
17. Always wear a dust mask when working in a dusty environment.

MAINTENANCE AND STORAGE

1. Check the mounting bolts at frequent intervals to make sure that they are properly tightened
2. Never store the machine with fuel in the fuel tank inside a building where ignition sources are present such as hot water and space heaters, clothes dryers, and the like. Allow the engine to cool before storing in any enclosure.
3. Always refer to the owner's manual when you store the rotary broom.
4. Maintain or replace safety and instruction labels, as necessary.
5. Inspect the tractor's air filter every day. Clean it or replace it. Change the oil more often when working in dusty conditions. See the tractor owner's manual.

WHENEVER YOU SEE THIS SYMBOL



**IT MEANS:
WARNING!
BECOME ALERT !
YOUR SAFETY IS INVOLVED!**



WARNING



TO PREVENT INJURIES AND FOR MORE TRACTION WHEN USING AN ATTACHMENT:

- Rear counterweight of 100 lbs. minimum is required to counterbalance the attachment's weight.
- Tractor manufacturer approved tire chains are required.
- Do not operate on a slope greater than 10°.
- When dismounting an attachment remove rear counterweights.

SAFETY DECALS

REPLACE IF DECALS ARE DAMAGED
SEE PARTS BREAKDOWN FOR DECAL LOCATION

IMPORTANT

READ & FOLLOW INSTRUCTIONS IN OWNER'S MANUAL BEFORE OPERATING.

ADJUSTMENT

- BRUSH PRESSURE HANDLE ADJUSTMENT
- BRUSH PRESSURE GAUGE
- TOP OF SQUARE BOX



- BRUSH PRESSURE INCREASED BY TURNING HANDLE COUNTER CLOCKWISE, MOVING GAUGE UP.
- BRUSH PRESSURE DECREASED BY TURNING HANDLE CLOCKWISE, MOVING GAUGE DOWN.

GENERAL SWEEPING

- HARD SURFACE SWEEPING DUST OR SNOW, ADJUST THE GAUGE FLUSH WITH TOP OF SQUARE BOX, RE-ADJUST TO COMPENSATE FOR BRUSH WEAR.

LAWN DETHATCHING & LEAF RAKING

- LOWER THE BROOM ONTO A HARD SURFACE & TURN THE HANDLE ADJUSTMENT CLOCKWISE TO LIFT THE BRUSH 1" FROM GROUND, RE-ADJUST AS NEEDED.

102386

Decal #102386

WARNING

TO AVOID PERSONAL INJURY:

- READ AND UNDERSTAND OWNER'S MANUAL BEFORE OPERATION.
- KEEP ALL BYSTANDERS AWAY FROM SWEEPING AREA.
- EYE PROTECTION MUST BE WORN AT ALL TIMES BY OPERATOR AND ANYONE WITHIN THE DISCHARGE AREA OF THE BRUSH.
- NEVER SWEEP TOWARD BYSTANDERS, BUILDINGS, CARS, ETC...
- BEFORE ADJUSTING OR SERVICING THE SWEEPER DISENGAGE BROOM, TURN OFF ENGINE, REMOVE KEY, SET PARKING BRAKE AND ALLOW ALL MOVING PARTS TO STOP.
- KEEP BRUSH MATERIAL AWAY FROM INTENSE HEAT AND FLAME.
- DO NOT ALLOW PASSENGERS ON SWEEPER OR TRACTOR.
- DO NOT OPERATE SWEEPER OR TRACTOR UNLESS GUARDS AND ALL SHIELDS ARE IN PLACE. KEEP AWAY FROM ROTATING PARTS.
- ALWAYS USE A DUST MASK WHEN WORKING IN DUSTY CONDITIONS.
- MINIMUM 100 LBS REAR COUNTERWEIGHT IS REQUIRED TO COUNTERBALANCE BROOM'S WEIGHT.
- IN WINTER, APPROVED TIRE CHAINS ARE REQUIRED.

102384

Decal #102384

ASSEMBLY

STEP 1 ROTARY BROOM PREPARATION

IMPORTANT: TORQUE ALL BOLTS ACCORDING TO TORQUE SPECIFICATION TABLE (SEE TABLE OF CONTENTS) WHEN STATED: TIGHTEN FIRMLY. REFER TO PARTS BREAKDOWN SECTION FOR PARTS IDENTIFICATION.

See adaptor mounting Instruction Booklet for adaptor preparation and installation of the adaptor.

Install the joint block (item 1) on the latch rod (item 2) and secure with a retaining ring (item 3).

Install the control rod (item 4) in the joint block (item 1) and secure with a 2.5 mm hair pin (item 5).

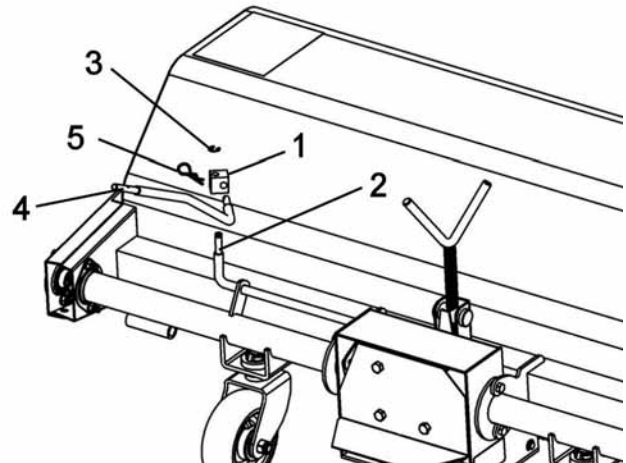

Prepare broom

Insert the parking stands (item 1) in the stand holders (item 2). Secure with a 5/32 x 1" cotter pin (item 3) in the upper hole (item 4) and a hair pin 2.5 mm (item 5) in the lower hole (item 6) of each parking stand.

This will allow the broom to rest on the stand.

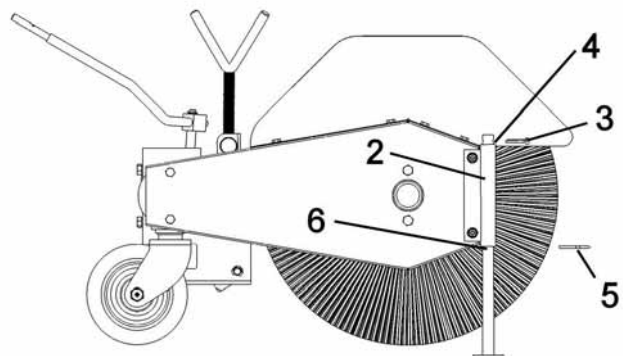

Install the parking stands

ASSEMBLY

STEP 2 ROTARY BROOM INSTALLATION



WARNING



TO PREVENT INJURIES:

Stop the motor.

Apply parking brake.

Remove the ignition key.

Disconnect the wire from the spark plug(s) and keep away from spark plug(s) to prevent accidental starting.

Attach the rotary broom to the subframe as shown.

Make sure the rotary broom is pushed in until locked into place by the springs (item 1).

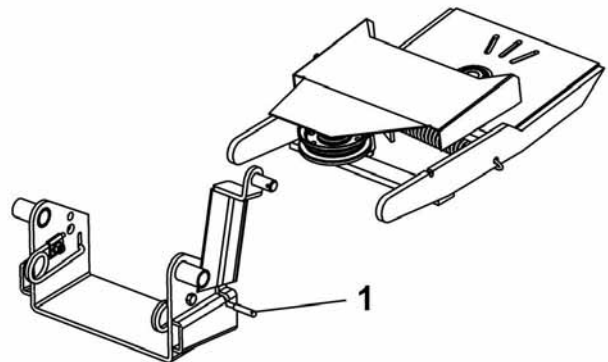

Attach rotary broom to subframe

Follow the instructions for the belt installation in the Adaptor Instruction Booklet and the Subframe Owner's Manual.



DANGER



NEVER OPERATE THE ROTARY BROOM WITHOUT:

Brush hood

Belt guard

Gear box guard

Extension guard and any other safety protection devices in place.

ASSEMBLY

HANDLE INSTALLATION

Install the 1/2 x 3" handgrip (item 1) on the handle (item 2).

Insert the handle through the plastic grommet on the handle support (item 3) and on the control rod (item 4).

Secure with a 2.5 mm hair pin (item 5).

NOTE: If the subframe includes a handle extension (item 6), install it between the control rod (item 4) and the handle (item 2).

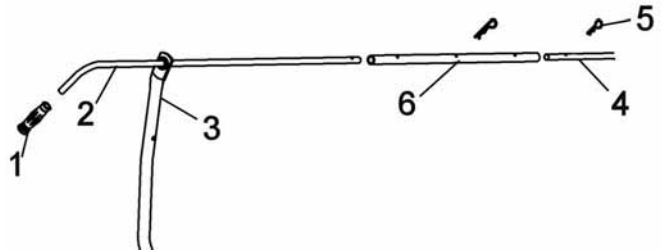

Install the handle

VERIFY TRACTOR TIRE PRESSURE:

Check and adjust tractor tire pressure as follows:

Front tires: 14-15 psi

Back tires: 7-8 psi

Tire pressure must be even on both sides of the tractor.

OPERATION



WARNING



BEFORE MAKING ANY ADJUSTMENTS:
Stop the motor.
Apply parking brakes.
Remove the ignition key.
Disconnect the wire from the spark plug(s) and keep away from spark plug(s) to prevent accidental starting.

ROTARY BROOM ANGLE ADJUSTMENT

By turning the handle counter clockwise you unlock the latch and by pulling or pushing, you set the angle 0° to 20° on each side.

PRESSURE ON THE BRUSH ADJUSTMENT

By turning the adjustment screw (item 1) counter clockwise, the gauge (item 3) moves higher and the pressure of the brush on the ground increases. By turning the adjusting screw clockwise, the gauge moves lower on the gear box frame (item 2) and the pressure of the brush on the ground decreases.

IMPORTANT: Maintain the gauge (item 3) even with the top of the gear box frame (item 2) or lower for general hard surface sweeping. Adjust frequently to compensate for brush wear. Remember to sweep with the tips of the bristles like a broom and not with the sides of the bristles like a mop. Too much pressure can decrease the brush life up to 95%.

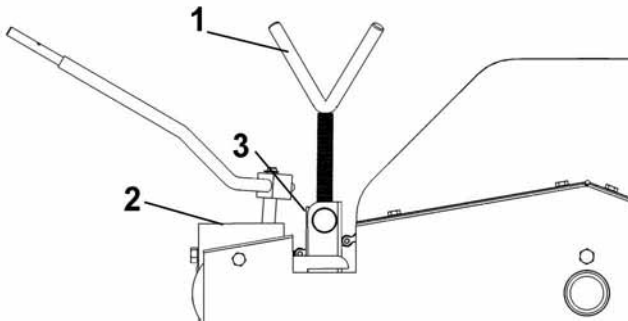

Adjust the pressure on the brush



WARNING



TO PREVENT INJURIES AND FOR MORE TRACTION WHEN USING AN ATTACHMENT:

- Rear counterweights of 100 lbs. minimum are required to counter-balance attachment's weight.
- Tractor manufacturer approved tire chains are required.
- Do not operate on slopes greater than 10°.
- When dismantling an attachment remove rear counterweights.**

GENERAL SWEEPING

Minimize dust by reducing brush speed and by sweeping after rain or on a day with high moisture.

SNOW SWEEPING

Adjust the gauge (item 3) to be even with the top of gear box frame. The broom works well for light snow removal.

Sweep with the wind blowing in the direction of broom discharge.

NOTE: Foreign objects in the snow may be thrown faster than the snow itself.

Frequently clean the snow and ice accumulation from the top and bottom of the broom hood.

LAWN DETHATCHING AND LEAF RAKING:

Lower the broom on a hard surface and lift the brush 1" from the ground by turning the adjusting screw clockwise. The brush is supported by dolly wheels. This adjustment is normally satisfactory but you may raise or lower depending upon grass height.

Low brush speed and ground speed is best for lawn dethatching and leaf raking.

Never sweep with the sides of bristles!

Sweep with the tips!
Do not mop!

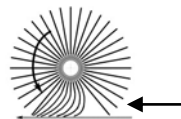

Too much pressure=
Shortens brush life!

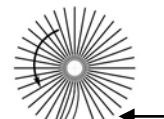

Flick action

Road surface

MAINTENANCE & DISMOUNTING

MAINTENANCE

1. Check oil level in gear box every fifty hours and fill to plug level with SAE-90-EP oil when necessary.
2. Grease the wheel axles after every eight hours of use.
3. Chain: do not lubricate when used in dusty conditions. After use, wash clean and lubricate.
4. Adjust the chain frequently by moving the idler sprocket to give 1/2" deflection.
5. Frequently clean the interior and exterior of hood, dirt, mud, ice, etc, accumulation adds weight on the brush and could result in premature wear of brush.
6. Check mounting bolts at frequent intervals for proper tightness to be sure equipment is in safe working conditions.
7. Apply oil at all pivot points.

BRUSH REPLACEMENT:

See parts breakdown section for parts identification.

1. Remove the hood (item 53).
2. Loosen the chain idler sprocket (item 24).
3. Remove the bolts (item 22) from both flanges (item 68) that holds the brush hollow shaft.
4. Remove the brush hollow shaft (item 52) from the broom frame (item 31).
5. Loosen the set screw and remove the right bearing (item 50) from the brush hollow shaft
6. Remove the bolt (item 51) which retains the brush to the brush hollow shaft.
7. Remove the brush tube from axle.
8. Install the new brush by reversing the procedure.
9. Adjust the tension on the chain by moving the idler sprocket to give a 1/2" deflection on the chain.

DISMOUNTING

1. Select a level surface, set parking brake, stop the engine, and remove the ignition key to prevent accidental starting.
2. Straighten the broom perpendicular with the tractor.
3. Set the parking stands in their most extended position Make sure the brush bristles never touch the ground.
4. Lower the broom to the ground.
5. Remove the hair pin from the handle and remove handle.
6. Loosen and remove the belt from the tractor drive pulley and idlers.
7. Detach the broom from the subframe by lifting the spring locks and pulling back the broom one side at a time.
8. Remove the rear counterweights.

END OF SEASON STORAGE

1. Clean the broom and inside of the hood.
2. Lubricate all grease fittings and all moving parts.
3. Store broom on parking stand. Make sure the brush bristles never touch the ground.
4. If brush bristles are exposed to direct sunlight, protect the bristles with a tarp.
5. Store the broom in a dry place.

TROUBLESHOOTING

PROBLEM	POSSIBLE CAUSES	CORRECTIVE ACTION
<p>Brush wears out prematurely or does not wear out evenly.</p> <p>The brush turns jerkily.</p>	<p>The pressure on the brush is not well adjusted.</p> <p>Too much pressure on the brush, it will wear out up to 5 times faster.</p>	<p>Reduce the pressure on the brush when on the ground.</p> <p>Adjust when needed to compensate for the wearing out of the brush.</p> <p>Always sweep with the tips of the bristles like a broom and not with the sides of the bristles like a mop.</p> <p>Maintain the gauge even with the top of the gear box frame or lower when sweeping hard surfaces.</p>
<p>The brush does not sweep well.</p>	<p>Debris accumulation.</p>	<p>Clean the inside and outside of the hood frequently during operation.</p> <p>Dirt, mud, ice, etc.. accumulation adds weight on the brush and could result in premature wear of the brush.</p>
<p>The brush is too aggressive when lawn dethatching or leaf raking.</p> <p>The brush does not turn on the grass.</p>	<p>Too much pressure on the brush.</p>	<p>Lower the broom on a hard surface and lift brush 1" from the ground by turning the adjusting screw clockwise.</p> <p>Adjust from time to time if necessary.</p>
<p>The chain wears out prematurely.</p>	<p>Inappropriate lubrication.</p>	<p>Do not lubricate the chain during operation. Wait until the job is finished.</p> <p>Wash the rotary broom and lubricate the chain.</p> <p>Let the broom turn a few moments so the oil penetrates in the chain.</p>
<p>The sprocket wears out prematurely.</p>	<p>Chain is not adjusted.</p>	<p>Check the chain adjustment frequently (too tight, too loose).</p>
<p>The brush turns backwards.</p>	<p>The belt is not installed in the right way.</p>	<p>Remove the belt and reinstall as explained in the subframe Owner's Manuel, section broom installation.</p>
<p>Loss of steering.</p>	<p>Too much pressure on the brush.</p>	<p>Reduce pressure on the brush. If problem persists, contact your dealer for more information.</p>
<p>The bristles take a bad form or shape.</p>	<p>The broom was not stored on the parking stands.</p>	<p>Wash the broom with warm water or warm steam. Leave in raised position and let it turn a few turns. The brush should take its original shape.</p>

PARTS BREAKDOWN / NOMENCLATURE DES PIÈCES ROTARY BROOM / BALAI ROTATIF

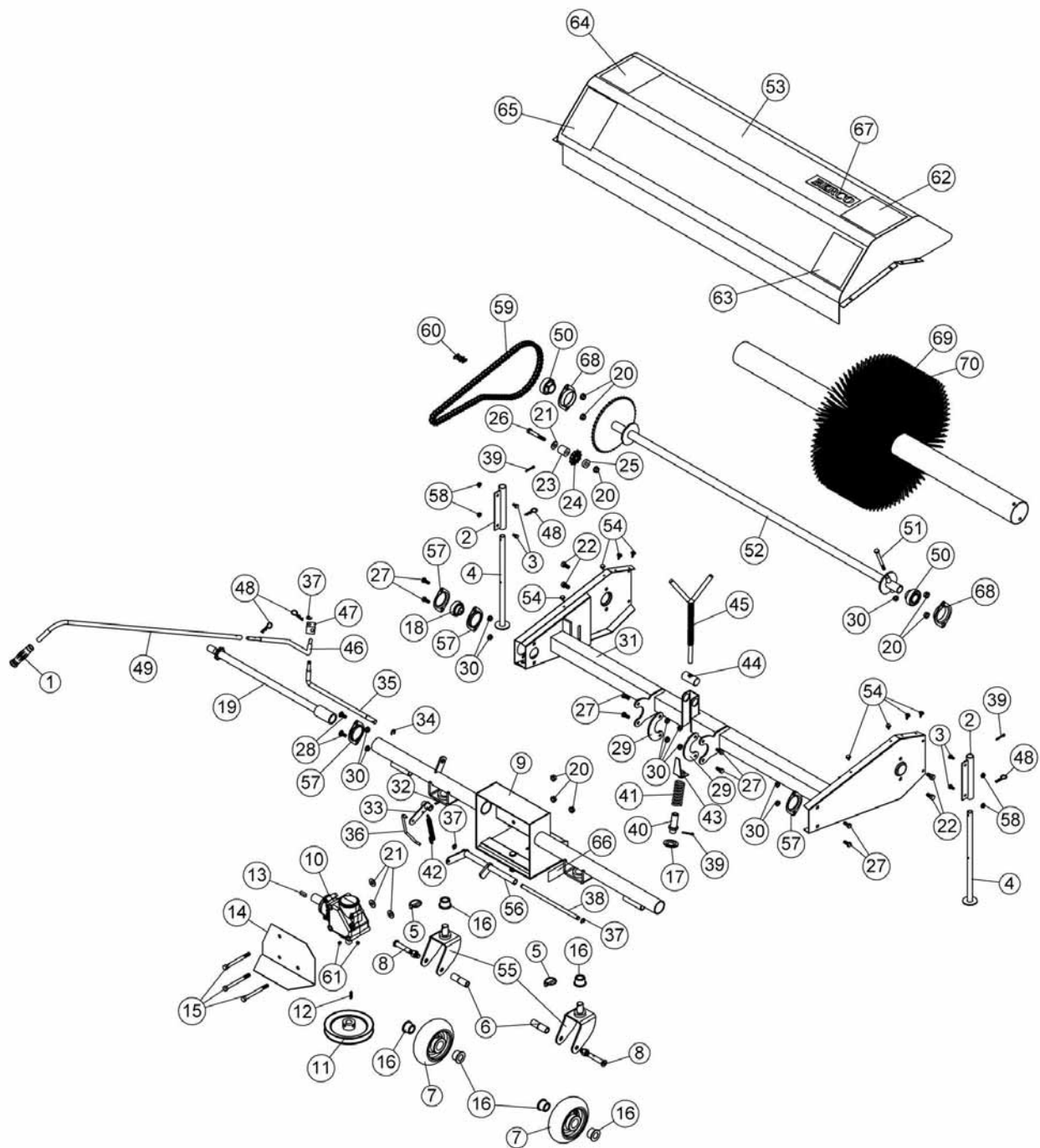

PARTS LIST / LISTE DES PIÈCES

Ref. Réf.	English description	Description française	Qty. Qté.	Part # Pièce #
1	Handgrip	Poignée	1	102062
2	Stand holder	Support de pied	2	102392
3	Hex. bolt 1/4" n.c. x 1/2"	Boulon hex. 1/4" n.c. x 1/2"	4	O/L
4	Parking stand	Pied de stationnement	2	102394
5	Lynch pin	Goupille à anneau	2	104481
6	Wheel bushing	Douille de roue	2	103483
7	Wheel 6"	Roue 6"	2	103484
8	Axle and nut	Essieu et écrou	2	102372
9	Gear box frame	Châssis de la boîte d'engrenage	1	104606
10	Gear box	Boîte d'engrenage	1	102205
11	V pulley	Poulie en V	1	102043
12	Key 3/16" x 3/16" x 1.000"	Clé 3/16" x 3/16" x 1.000"	1	102379
13	Key 8 x 7 x 25mm	Clé 8 x 7 x 25mm	1	102030
14	Gear box guard	Garde de la boîte d'engrenage	1	104066
15	Hex. bolt 3/8" n.c. x 4"	Boulon hex. 3/8" n.c. x 4"	3	O/L
16	Delrin bushing	Coussinet Delrin	6	103482
17	Special washer	Rondelle spéciale	1	102429
18	Bearing with set screw	Roulement à billes avec vis à pression	1	102864
19	Drive shaft	Arbre de commande	1	104063
20	Flange nut 3/8" n.c.	Écrou à bride 3/8" n.c.	8	O/L
21	Flat washer 7/16" hole	Rondelle plate 7/16" trou	4	O/L
22	Hex. bolt 3/8" n.c. x 3/4"	Boulon hex. 3/8" n.c. x 3/4"	4	O/L
23	Spacer	Douille	1	102286
24	Idler sprocket	Pignon tendeur	1	102027
25	Spacer	Espaceur	1	102241

O/L = Obtain locally/obtenir localement

PARTS LIST / LISTE DES PIÈCES

Ref. Réf.	English description	Description française	Qty. Qté.	Part # Pièce #
26	Hex. bolt 3/8" n.c. x 2 1/2"	Boulon hex 3/8" n.c. x 2 1/2"	1	O/L
27	Hex. bolt 5/16" n.c. x 3/4"	Boulon hex. 5/16" n.c. x 3/4"	8	O/L
28	Carriage bolt 5/16" n.c. x 3/4"	Boulon à carrosserie 5/16" n.c. x 3/4"	2	O/L
29	Collar	Collet	2	102402
30	Flange nut 5/16" n.c.	Écrou à bride 5/16" n.c.	11	O/L
31	Broom frame	Châssis du balai	1	104061
32	Roll pin 3/16" x 3/4"	Goupille roulée 3/16" x 3/4"	1	O/L
33	Rocker arm	Culbuteur	1	104067
34	Retaining ring	Bague de retenue	1	102377
35	Latch rod	Tige de loquet	1	102287
36	Rod link	Tige de raccord	1	104072
37	Retaining ring	Bague de retenue	3	102378
38	Latch shaft	Arbre du loquet	1	102198
39	Cotter pin 5/32" x 1"	Goupille fendue 5/32" x 1"	3	O/L
40	Spring holder	Support de ressort	1	102197
41	Spring	Ressort	1	102201
42	Spring 1/2"	Ressort 1/2"	1	102003
43	Gauge	Jauge	1	102367
44	Special nut	Écrou spécial	1	102288
45	Adjustment screw	Vis d'ajustement	1	102200
46	Control rod	Tige de contrôle	1	102291
47	Joint block	Bloc de joint	1	102275
48	Hair pin 2.5mm	Goupille à ressort 2.5mm	4	102013
49	Handle	Poignée	1	102292
50	Bearing with set screw	Roulement à billes avec vis à pression	2	102755

O/L = Obtain locally/obtenir localement

PARTS LIST / LISTE DES PIÈCES

Ref. Réf.	English description	Description française	Qty. Qté.	Part # Pièce #
51	Hex. bolt 5/16" n.c. x 3 1/2"	Boulon hex. 5/16" n.c. x 3 1/2"	1	O/L
52	Brush hollow shaft	Arbre de brosse	1	104064
53	Hood	Capot	1	104060
54	Tapping screw 1/4"-14 x 1/2"	Vis taraudeuse 1/4"-14 x 1/2"	8	O/L
55	Wheel fork	Fourche de la roue	2	104458
56	Latch	Loquet	1	102283
57	Flangette	Flangette	4	102212
58	Flange nut 1/4" n.c.	Écrou à bride 1/4" n.c.	4	O/L
59	Roller chain #40 x 86 links/conn.link	Chaîne # 40 x 86 mailles/maille acc.	1	102375
60	Connecting Link #40	Maille d'accouplement #40	1	102040
61	Hex. socket set screw 5/16" n.c. x 5/16"	Vis à pression hex. 5/16" n.c. x 5/16"	2	O/L
62	Important decal	Décalque important	1	102386
63	Warning decal	Décalque warning	1	102384
64	Important decal	Décalque important	1	102387
65	Attention decal	Décalque attention	1	102385
66	Serial number	Numéro de série	1	REF
67	Berco decal	Décalque Berco	1	102471
68	Flangette	Flangette	2	102680
69	Nylon brush	Brosse en nylon	1	104065
70	Polypropylene brush	Brosse de polypropylène	1	104010

O/L = Obtain locally/obtenir localement

TORQUE SPECIFICATION TABLE

GENERAL TORQUE SPECIFICATION TABLE USE THE FOLLOWING TORQUES WHEN SPECIAL TORQUES ARE NOT GIVEN

NOTE: These values apply to fasteners as received from supplier, dry or when lubricated with normal oil. They do not apply if special graphited or moly disulphide greases or other extreme pressure lubricants are used. This applies to both UNF and UNC threads.

SEE Grade No.		2				5				8 *			
BOLT HEAD IDENTIFICATION MARKS AS PER GRADE NOTE MANUFACTURING MARKS WILL VARY		TORQUE				TORQUE				TORQUE			
BOLT SIZE		POUNDS FEET		NEWTON-METERS		POUNDS FEET		NEWTON-METERS		POUNDS FEET		NEWTON-METERS	
Inches	Millimetre	Min.	Max.	Min.	Max.	Min.	Max.	Min.	Max.	Min.	Max.	Min.	Max.
1/4"	6.35	5	6	6.8	8.13	9	11	12.2	14.9	12	15	16.3	30.3
5/16"	7.94	10	12	13.6	16.3	17	20.5	23.1	27.8	24	29	32.5	39.3
3/8"	9.53	20	23	27.1	31.2	35	42	47.5	57	45	54	61	73.2
7/16"	11.11	30	35	40.7	47.4	54	64	73.2	86.8	70	84	94.9	113.9
1/2"	12.7	45	52	61	70.5	80	96	108.5	130.2	110	132	149.2	179
9/16"	14.29	65	75	88.1	101.6	110	132	149.2	179	160	192	217	260.4
5/8"	15.88	95	105	128.7	142.3	150	180	203.4	244.1	220	264	298.3	358
3/4"	19.05	150	185	203.3	250.7	270	324	366.1	439.3	380	456	515.3	618.3
7/8"	22.23	160	200	216.8	271	400	480	542.4	650.9	600	720	813.6	976.3
1"	25.4	250	300	338.8	406.5	580	696	786.5	943.8	900	1080	1220.4	1464.5

*Thick nuts must be used with grade 8 bolts.

METRIC BOLT TORQUE SPECIFICATIONS							
		COARSE THREAD			FINE THREAD		
Size Screw	Grade No.	Pitch (mm)	Pounds Feet	Newton-Meters	Pitch (mm)	Pounds Feet	Newton-Meters
M6	4T	1.00	3.6 - 5.8	4.9 - 7.9	-	-	-
	7T		5.8 - 9.4	7.9 - 12.7		-	-
	8T		7.2 - 10	9.8 - 13.6		-	-
M8	4T	1.25	7.2 - 14	9.8 - 19	1.00	12 - 17	16.3 - 23
	7T		17 - 22	23 - 29.8		19 - 27	25.7 - 36.6
	8T		20 - 26	27.1 - 35.2		22 - 31	29.8 - 42
M10	4T	1.50	20 - 25	27.1 - 33.9	1.25	20 - 29	27.1 - 39.3
	7T		34 - 40	46.1 - 54.2		35 - 47	47.4 - 63.7
	8T		38 - 46	51.5 - 62.3		40 - 52	54.2 - 70.5
M12	4T	1.75	28 - 34	37.9 - 46.1	1.25	31 - 41	42 - 55.6
	7T		51 - 59	69.1 - 79.9		56 - 68	75.9 - 92.1
	8T		57 - 66	77.2 - 89.4		62 - 75	84 - 101.6
M14	4T	2.00	49 - 56	66.4 - 75.9	1.50	52 - 64	70.5 - 86.7
	7T		81 - 93	109.8 - 126		90 - 106	122 - 143.6
	8T		96 - 109	130.1 - 147.7		107 - 124	145 - 168
M16	4T	2.00	67 - 77	90.8 - 104.3	1.50	69 - 83	93.5 - 112.5
	7T		116 - 130	157.2 - 176.2		120 - 138	162.6 - 187
	8T		129 - 145	174.8 - 196.5		140 - 158	189.7 - 214.1
M18	4T	2.00	88 - 100	119.2 - 136	1.50	100 - 117	136 - 158.5
	7T		150 - 168	203.3 - 227.6		177 - 199	239.8 - 269.6
	8T		175 - 194	237.1 - 262.9		202 - 231	273.7 - 313
M20	4T	2.50	108 - 130	146.3 - 176.2	1.50	132 - 150	178.9 - 203.3
	7T		186 - 205	252 - 277.8		206 - 242	279.1 - 327.9
	8T		213 - 249	288.6 - 337.4		246 - 289	333.3 - 391.6

ATTACHMENTS

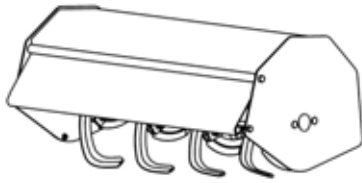

ROTARY TILLER #700312

Mounts to the rear of lawn, yard & garden tractors 14 to 25 HP. Comes complete with drive & manual lift mechanisms & mounting hardware.

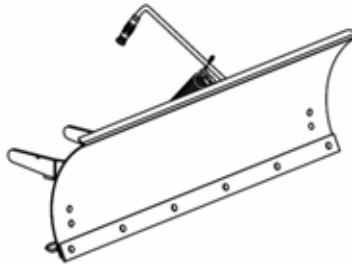

UTILITY BLADE #700266

Mounts on the same subframe as the snowblower & rotary broom.



SNOWBLOWER

#700255 40"
#700374-44"
#700378-48"

Fits on same subframe as rotary broom and utility blade.

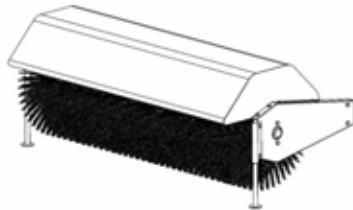

**ROTARY BROOM
#700380/#700381**

Fits on same subframe as snowblower & utility blade. Requires an adaptor.

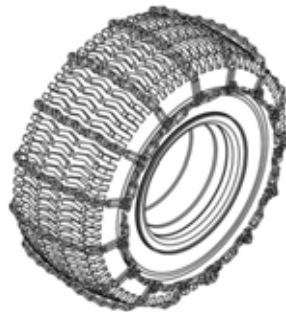

TIRE CHAINS

Two link spacing. Required for traction and safety.
Pkg. of 2

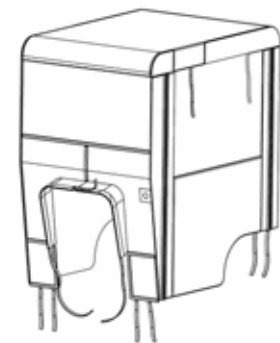

**TRACTOR WINTER CAB
#700423**

Universal type fits on a wide variety of lawn and garden tractors.

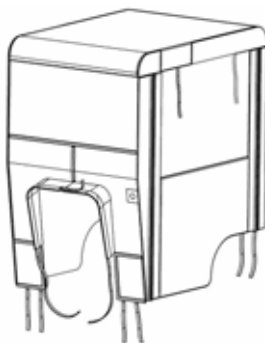

**TRACTOR SCREEN CAB
#700424**

Universal type fits on a wide variety of lawn and garden tractors.

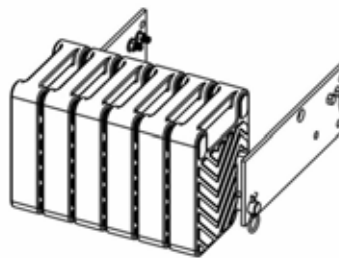

COUNTERWEIGHT

#700240 Universal rear weights
#700246 Rear weights Electrolux
Required for safety and traction.
Counterbalances weight of attachment.

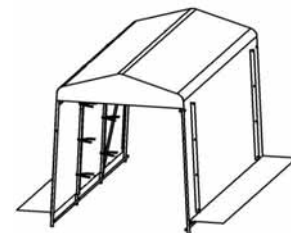

**TRACTOR / A.T.V. SHELTER
#700438**

Especially designed to put away your tractor or A.T.V with it's accessory.