



# OWNER'S MANUAL

## *Model Number*

700413-3 Subframe

700414-2 Compact Drive Mechanism

700415-2 Northeast Drive Mechanism



## ***Berco***

### ***Subframe & Drive Mechanism***

for

### ***HUSQVARNA, JONSERED, POULAN, RALLYE, WEDEATER & YARD PRO***

### ***tractors***

- \* ASSEMBLY
- \* OPERATION

- \* REPAIR PARTS
- \* MAINTENANCE

### **CAUTION:**

**READ & FOLLOW ALL SAFETY RULES & INSTRUCTIONS BEFORE  
OPERATING YOUR EQUIPMENT**



# LIMITED WARRANTY

## Conditions and Products Covered:

BERCOMAC guarantees any part of the product or accessory manufactured by BERCOMAC and found in the reasonable judgment of BERCOMAC to be defective in material and or workmanship will be repaired or replaced by an authorized dealer without charge up to our maximum labor rates and pre-established times. For replacement parts only standard ground freight services are covered. This warranty extends to the original retail purchaser only and is not transferable to any subsequent purchasers.

## Warranty Period

(from date of the original retail purchase)

- Residential use: 1 year
- Semi-commercial, professional or rental use: 90 days

**Exceptions Noted Below;** the following items are guaranteed by the original manufacturer and have their own warranty, conditions and limited time:

- Tire Chains: 90 days
- Engines: Will vary as per the manufacturer

Please refer to the engine manufacturer's warranty statement included with the unit. BERCOMAC is not authorized to handle warranty adjustments on engines.

## Items and Conditions NOT Covered:

This warranty does not cover the following:

- Pick-up or delivery charges or in-home services fees.
- Any damage or deterioration of the unit, parts and or finish of these due to normal use, wear and tear, or exposure.
- Cost of regular use or maintenance service or parts, such as gas, oil, lubricants, tune-up parts, and adjustments.
- Any part or accessory which has been altered, modified, misused, neglected, accidentally damaged or not properly installed, maintained, stored or repaired not in accordance with the instructions in the owner's manual.
- Repair due to normal wear and or any wear items such as shear pins, bolts, belts, etc.
- Expedited freight fee services for replacement parts.
- Shear bolts and shear pins are to be considered as a preventive measure not as an assured protection, any damages resulting from the lack of shear bolts breakage are not covered.

NOTE: All warranty work must be performed by an authorized dealer using original (manufacturer) replacement parts.

**NOTE:** Bercomac reserves the right to change or improve the design of any part or accessory without assuming any obligation to modify any product previously manufactured.

## Instructions for Obtaining Warranty Services:

Contact dealer where equipment was purchased or any other BERCOMAC service dealer to arrange service at their dealership. To locate a dealer convenient to you, access our website at [www.bercomac.com](http://www.bercomac.com). Don't forget to bring the product and your proof of purchase (sales receipt) to the BERCOMAC dealer.

## Owner's Responsibilities:

BERCOMAC's defective equipment or part must be returned to an authorized dealer within the warranty period for repairs. In the event that defective merchandise must be returned to manufacturer for repairs, freight fees are prepaid and a written authorization from BERCOMAC must be obtained by dealer prior to the shipment. This warranty extends only to equipment operated under normal conditions. To validate a warranty claim, it is the user's responsibility to maintain and service the unit as specified in the owner's manual or to have the unit serviced at their dealer at their expense.

## General Conditions:

The sole liability of BERCOMAC with respect to this warranty shall be strictly and exclusively repair and replacement as mentioned herein. BERCOMAC shall not have any liability for any other costs, loss or damage, including but not limited to, any incidental or consequential loss or damage.

In particular, without being limited to, BERCOMAC shall have no liability or responsibility for:

- Travel time, overtime, after hours time or other extraordinary repair charges or relating to repairs and or replacements outside of normal business hours.
- Rental of like or similar replacement equipment during the period of any, repair or replacement work.
- Any communicating or travel charges.
- Loss or damage to person or property other than that covered by the terms of this warranty.
- Any claims for lost revenue, lost profit or any similar costs as a result of damage or repair.
- Attorney's fees.

BERCOMAC's responsibility in respect to claims is limited to making the required repairs or replacement without charge up to our maximum labor rates and pre-established times and no claim of breach of warranty shall be cause for cancellation or rescission of the contract of sale of any product or accessory.

This warranty gives you specific legal rights. You may also have other rights, which vary from state to state.

# TABLE OF CONTENTS

	PAGE
INTRODUCTION .....	2
SAFETY PRECAUTIONS .....	3
ASSEMBLY	
Step 1: Tractor Preparation .....	5
Step 2: Subframe Installation .....	6
Step 3: Drive Mechanism Preparation .....	12
Step 4: Drive Mechanism Installation .....	16
Step 5: Snowblower Installation .....	18
Rotary Broom Installation .....	20
Blade Installation .....	22
MAINTENANCE & DISMOUNTING	
Maintenance .....	23
Drive Mechanism Dismounting .....	23
Belt Replacement .....	23
End of Season Storage .....	23
PARTS BREAKDOWN AND LISTS	
Compact Drive Mechanism .....	24
Northeast Drive Mechanism .....	26
Subframe .....	28
TORQUE SPECIFICATION TABLE .....	31
ATTACHMENTS .....	32
TROUBLESHOOTING	
See attachment owner's manual for this section. (Snowblower, Blade, Rotary Broom)	

# INTRODUCTION

**TO THE PURCHASER**

This new accessory was carefully designed to give years of dependable service. This manual has been provided to assist in the safe operation and servicing of your attachment.

**NOTE:** All photographs and illustrations in the manual may not necessarily depict the actual models or attachment, but are intended for reference only and are based on the latest product information available at the time of publication.

Familiarize yourself fully with the safety recommendations and operating procedures before putting the machine to use. Carefully read, understand and follow these recommendations and insist that they be followed by those who will use this attachment.



**THIS SAFETY ALERT SYMBOL IDENTIFIES AN IMPORTANT SAFETY MESSAGE IN THIS MANUAL THAT HELPS YOU AND OTHERS AVOID PERSONAL INJURY OR EVEN DEATH. DANGER, WARNING, AND CAUTION ARE SIGNAL WORDS USED TO IDENTIFY THE LEVEL OF HAZARD. HOWEVER, REGARDLESS OF THE HAZARD, BE EXTREMELY CAREFUL.**

**DANGER:** Signals an extreme hazard that will cause serious injury or death if recommended precautions are not followed.

**WARNING:** Signals a hazard that may cause serious injury or death if the recommended precautions are not followed.

**CAUTION:** Signals a hazard that may cause minor or moderate injury if the recommended precautions are not followed.

Record your attachment serial number and purchase date in the section reserved below (there is no serial number on the subframe). Your dealer requires this information to give you prompt, efficient service when ordering replacement parts. Use only genuine parts when replacements are required.

If warranty repairs are required please present this registration booklet and original sales invoice to your selling dealer for warranty service.

**This manual should be kept for future reference.  
Please check if you have received all the parts for your kit with the list of the bag and the list of the box.**

<b>SERIAL NUMBER :</b> (IF APPLICABLE)	
<b>MODEL NUMBER:</b>	
<b>PURCHASE DATE :</b>	



## SAFETY PRECAUTIONS



Careful operation is your best insurance against an accident. Read this section carefully before operating the vehicle and accessory. This accessory is capable of amputating hands and feet and throwing objects. Failure to observe the following safety instructions could result in serious injury. All operators, no matter how experienced they may be, should read this and other manuals related to the vehicle and accessory before operating. It is the owner's legal obligation to instruct all operators in safe operation of the accessory.

### GLOSSARY:

In this manual, right and left sides are determined by sitting on the seat of the vehicle facing forward.

In this manual, "accessories" means attachments (snowblower, rotary broom, blade etc.) that you install on the vehicle (lawn tractors, A.T.V. s etc).

### TRAINING:



This symbol, "Safety Alert Symbol", is used throughout this manual and on the accessory's safety labels to warn of the possibility of serious injury. Please take special care in reading and understanding the safety precautions before operating the vehicle and accessory.

1. Read this owner's manual carefully. Be thoroughly familiar with the controls and proper use of the vehicle and accessory. Know how to stop the unit and disengage the controls quickly.
2. Never allow children to operate the vehicle nor the accessory. Never allow adults to operate the vehicle nor the accessory without proper instructions.
3. No one should operate the vehicle nor the accessory while intoxicated or while taking medication that impairs the senses or reactions.
4. Keep the area of operation clear of all people, particularly small children and pets.

### PREPARATION:

1. Thoroughly inspect the area where the accessory is to be used and remove door mats, all foreign objects and the like.
2. For motorized accessories, disengage all clutches and shift into neutral before starting engine.
3. Do not operate the accessory without wearing adequate winter outer garments. Avoid loose fitting clothing that can get caught in moving parts. Wear footwear that will improve footing on slippery surfaces.

4. Handle fuel with care, it is highly flammable.

- a) Use approved fuel container.
  - b) Never add fuel to a running engine or hot engine.
  - c) Fill fuel tank outdoors with extreme care. Never fill fuel tank indoors.
  - d) Never fill containers inside a vehicle, or on a truck or a trailer bed with a plastic liner. Always place containers on the ground, away from your vehicle, before filling.
  - e) When practical, remove gas-powered equipment from the truck or trailer and refuel it on the ground. If this is not possible, then refuel such equipment on a trailer with a portable container, rather than from a gasoline dispenser nozzle.
  - f) Keep the nozzle in contact with the rim of the fuel tank or container opening at all times, until refueling is complete. Do not use a nozzle lock-open device.
  - g) Replace fuel cap securely and wipe up spilled fuel.
  - h) If fuel is spilled on clothing, change clothing immediately.
5. Never attempt to make any adjustments while the engine (motor) is running (except when specifically recommended by manufacturer).
  6. Let the vehicle and accessory adjust to outdoor temperatures before using.
  7. Never use an accessory without proper guards, plates, or other safety protective devices in place
  8. Always make sure to wear the appropriate safety equipment required (glasses, muffs, mask...) for each type of product. See operation section.
  9. Always make sure of having safe traction on the vehicle by using the recommended accessories (chains, A.T.V. tracks, counterweights...). See operation section.
  10. **Never modify the accessory or any part without the written consent from the manufacturer.**



## SAFETY PRECAUTIONS



### OPERATION:

1. Do not put hands or feet near, under or inside rotating parts.
2. Exercise extreme caution when operating on or crossing gravel drives, walks or roads. Stay alert for hidden hazards or traffic. Do not carry passengers.
3. After striking a foreign object, stop the engine (motor), disconnect the wire from the spark plug(s) and keep wire away to prevent accidental starting. Thoroughly inspect the accessory for any damage and repair damage before restarting and using the accessory.
4. If the unit should start to vibrate abnormally, stop the engine (motor) and check immediately for the cause. Vibration is generally a warning of trouble.
5. Take all possible precautions when leaving the vehicle unattended. Disengage the power take-off, lower the attachment, place the transmission into neutral, set the parking brake, stop the engine and remove the contact key.
6. Do not run the engine indoors, except when starting the engine and for transporting in or out of the building. Do not operate or let motor run in a storage area without ventilation because gas contains carbon monoxide which is odorless, colorless and can cause death.
7. Never use the accessories across the face of slopes, go from top to bottom. Exercise extreme caution when using equipment on slopes. Do not attempt to clear a steep slope.
8. Never tolerate bystanders in the working zone. Never use an accessory in the direction of bystanders, it might throw gravel or debris that can hurt people or damage property.
9. Never operate the accessory at high transport speeds on slippery surfaces. Use care when backing up.
10. Do not carry passengers.
11. Disengage power to the accessory when it is transported or not in use.
12. Never operate the accessory without good visibility or light.

13. Keep the accessory away from heat sources or flames.

### MAINTENANCE AND STORAGE

1. When cleaning, repairing or inspecting the vehicle and accessory, make certain that all moving parts have stopped. Disconnect wire from the spark plug(s) and keep wire away to prevent accidental starting.
2. Check all the bolts and components at frequent intervals to make sure that they are properly tightened.
3. Never store a motorized accessory with fuel in the fuel tank inside a building where ignition sources are present such as hot water and space heaters, clothes dryers, and the like. Allow the engine to cool before storing in any enclosure.
4. Always refer to the owner's manual when you store the accessory and vehicle for a prolonged or an unspecified length of time.
5. Maintain or replace safety and instruction labels, as necessary.
6. For winter accessories, (if applicable), let the engine run for a few minutes after clean snow in order to prevent the rotary parts from freezing.
7. Inspect the vehicle's and accessory's air filter every day. Clean it or replace it as necessary. Change the oil more often when working in dusty conditions. See the vehicle's and accessory's owner's manual.



**THIS SYMBOL MEANS  
DANGER !  
BECOME ALERT !  
YOUR SAFETY IS INVOLVED !**

# ASSEMBLY

**IMPORTANT: TORQUE ALL BOLTS ACCORDING TO TORQUE SPECIFICATION TABLE (SEE TABLE OF CONTENTS) WHEN STATED: TIGHTEN FIRMLY. REFER TO PARTS BREAKDOWN SECTION FOR PARTS IDENTIFICATION.**

**NOTE: This subframe was designed to fit various models of tractors. Make sure to follow the instructions that correspond to your tractor. The VGT frame sometimes requires a particular procedure.**

This subframe may be used to install different attachments (see attachments page). Once installed, it may remain permanently on the tractor. Before doing any modifications or installations on the tractor, open the tractor hood, disconnect the headlights and remove the hood. Disconnect the wire from the spark plug(s) and keep away from spark plug(s) to prevent accidental starting.

## STEP 1

### **TRACTOR PREPARATION:**

It is not necessary to remove mower deck at this step.

According to the model of the tractor, remove the mower front attaching supports if they are bolted to the outside of the tractor's frame on each side.

In order to install the subframe's supports, it may be necessary to remove certain bolts or certain parts.

**NOTE: Take note of the place and how the bolts and parts were installed in order to reinstall them in the same manner and place as before.**

If applicable, make sure that the belt guide does not touch any mobile part when reinstalled.

### **How to:**

Take the right support (item 1) and place it on the right side of the tractor's frame.

Align the hole (item 2) on the right support with the hole (item 3) which is about 2" (according to the model of the tractor) from the edge of the tractor's front frame. Remove all the bolts and parts from the tractor's frame that will interfere with the installation of the right support.

Do the same operation on the left side with the left support.

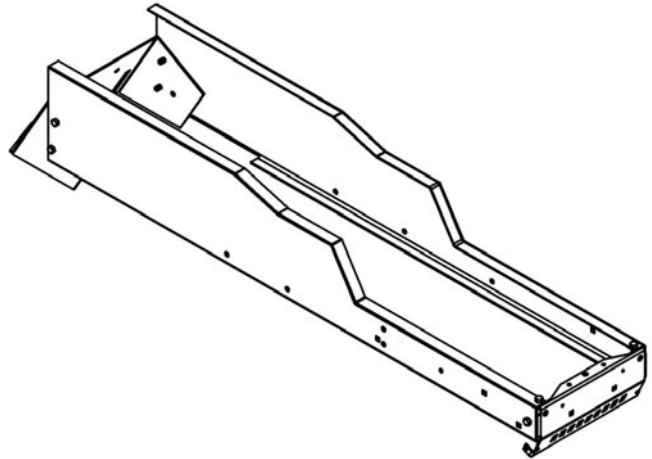

VGT Frame

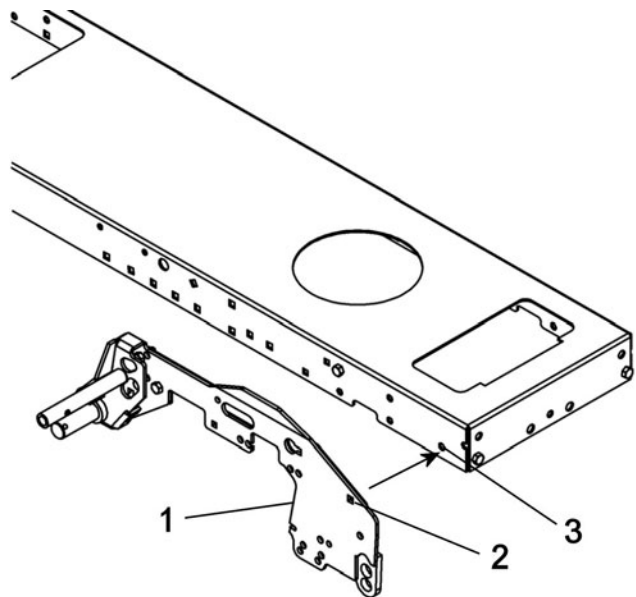

Align the holes in order to identify and remove the bolts and/or parts that come into interference with the support

# ASSEMBLY

## STEP 2 SUBFRAME INSTALLATION:

You must choose which brace pin (item 1 or item 4) that is appropriate for your tractor model.

### Tractors with a clutch that measures 5.5" high only (as shown):

You must use brace pin (item 1) and install it in the bottom holes of the right support (item 2) with two carriage bolts 3/8" x 1" (item 3; heads outside) and two 3/8" flange nuts.

Tighten firmly.

**NOTE:** This brace pin must be under the lawnmower belt.

The belt must not touch the brace pin.

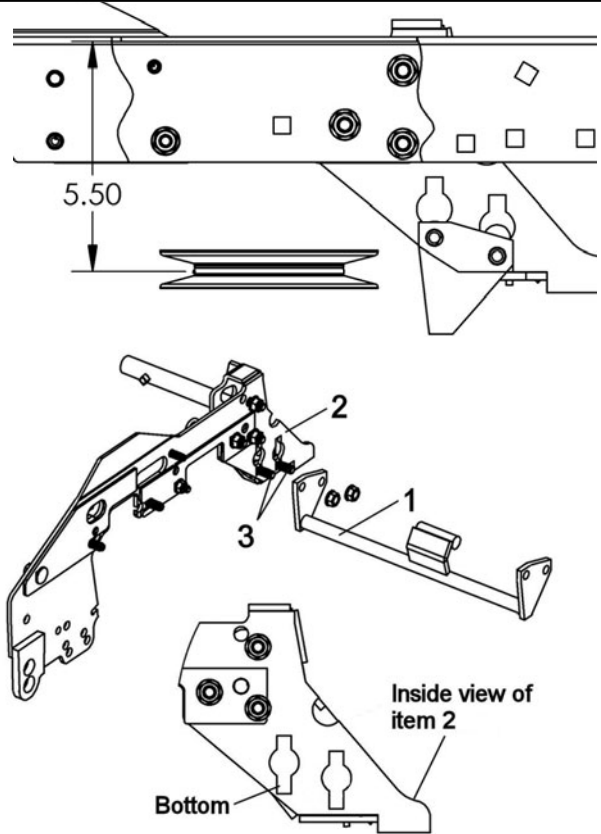

### For other tractors:

**Use brace pin (item 4) and follow the installation instructions below.**

Install the brace pin (item 4) on the right support (item 2) with two carriage bolts 3/8" x 1" (item 3; heads outside) and two 3/8" flange nuts.

Tighten firmly.

**NOTE:** Generally, the brace pin must be over the lawnmower belt and at the same time, as low as possible.

No interference is allowed. See chart below.

Tractor	Hole (inside view of item 2)	Position of brace pin
2006 & 2007 (most)	Bottom	Upwards
VGT frame	Bottom	Downwards
Others	Top	Upwards or downwards

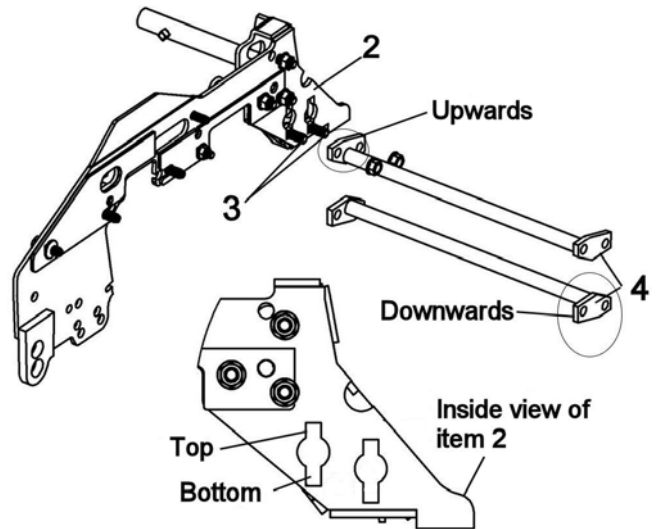

Install brace pin

**NOTE:** On certain models of 2010 tractors, the mower deck belt may touch the brace pin (item 4), if so, remove and use the brace pin (item 1) and follow the instruction at top of page.



# ASSEMBLY

**RIGHT SUPPORT:**

Install the right support (item 1) on the right side.

The chart identifies the hardware according to the holes in the tractor's frame. Even though some holes may not exist on certain models of tractors, **use the maximum of holes & bolts possible to ensure the solidity of the kit.**

Carr. B. = Carriage bolt; head towards the inside.  
 Hex B. = Hexagonal bolt; head towards the outside.  
 N/A = Not applicable

Item #	If square holes on tractor	If threaded holes on tractor
2	Carr. B 3/8 x 3/4" Flange nut 3/8"	Thread cutting screw 3/8 x 1"
3	N/A	Thread cutting screw 3/8 x 1"
4	N/A	Thread cutting screw 3/8 x 1"
5	Carr. B. 5/16 x 1" Flange nut 5/16"	N/A
6	N/A	Thread cutting screw 5/16 x 1"
7, 9	Hex B. 3/8 x 1" Flange nut 3/8"	N/A
8	Hex B. 3/8 x 1" Flange nut 3/8"	Thread cutting screw 3/8 x 1"
10, 11	N/A	Hex B. 3/8 x 1"
12	Set screw 5/16 x 1/2" (on support for the cab)	N/A
13	Tractor bolt and Spacer <b>(Round hole)</b>	N/A

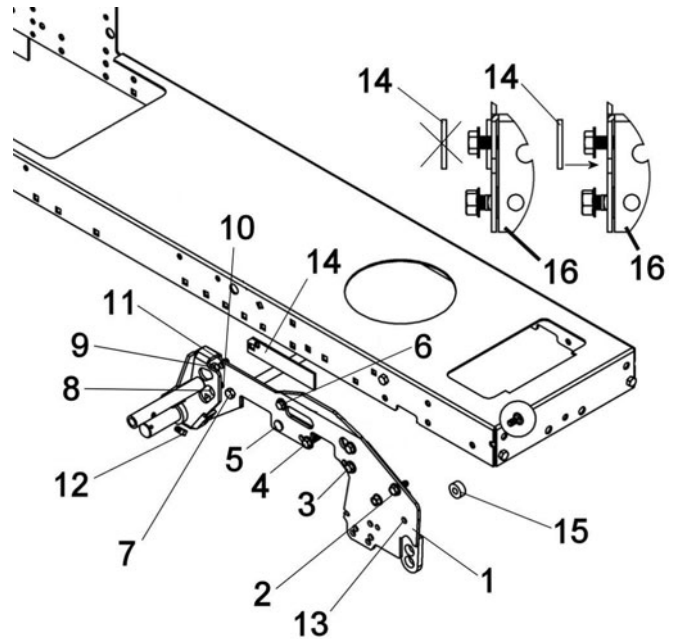

Install right support .

**NOTES:**

1. On new tractors, turning the wheels to the left will facilitate installation.
2. The spacer (item 15) is used to strengthen certain heat shields.

**If necessary**, slide the shim (item 14) between the tractor frame (item 16) and the right support; in line with hole (item 9 or item 11). (Make sure that the shim stays perpendicular with the top of the support).  
 Do not tighten the screws or the nuts.

# ASSEMBLY

## LEFT SUPPORT AND HANDLE SUPPORT:

Install the left support (item 1) and the handle support (item 17). Secure the brace pin (item 19)

The chart identifies the hardware according to the holes in the tractor's frame. Even though some holes may not exist on certain models of tractors, **use the maximum of holes & bolts possible to ensure the solidity of the kit.**

Carr. B. = Carriage bolt; head towards the inside.  
Hex B. = Hexagonal bolt; head towards the outside,  
**except 14 & 16.**

N/A = Not applicable.

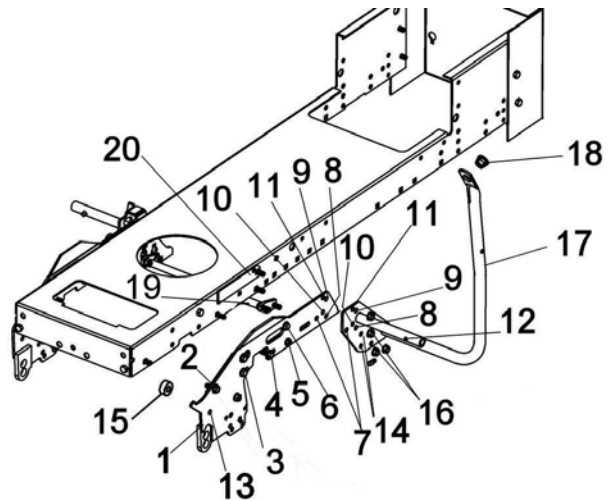

Install the left support and handle support

Item #	If square holes on tractor	If threaded holes on tractor
2	Carr. B. 3/8 x 3/4" Flange nut 3/8"	Thread cutting screw 3/8 x 1"
3	Hex. B. 3/8 x 1"	Thread cutting screw 3/8 x 1"
4	N/A	Thread cutting screw 3/8 x 1"
5	Carr. B. 5/16 x 1" Flange nut 5/16"	N/A
6	N/A	Thread cutting screw 5/16 x 1"
7, 9	Hex. bolt 3/8 x 1" Flange nut 3/8"	N/A
8	Hex. bolt 3/8 x 1" Flange nut 3/8"	Thread cutting screw 3/8 x 1"
10, 11	Hex. B 3/8 x 1" Flange nut 3/8" <b>(round holes)</b>	N/A
12	Set screw 5/16 x 1/2" (on support for the cab)	N/A
13	Tractor bolt and Spacer <b>(round holes)</b>	N/A
14, 16	Hex. B 3/8 x 1" Flange nut 3/8" <b>(round holes)</b>	N/A
18	Plastic grommet <b>(round hole in support)</b>	N/A

### **NOTE:**

1. On new tractors, turning the wheels to the right will facilitate installation .
2. The spacer (item 15) is used to strengthen certain heat shields.

# ASSEMBLY

If **necessary**, slide the shim (item 20, previous page) between the tractor frame and the support, in line with hole (item 9 or item 11). (Make sure that the shim stays perpendicular with the top of the support).

Slightly tighten the screws and bolts.

Make sure that the brace pin stays straight and does not come into contact with any part of the tractor (ex: the engine belt when mower deck is in raised position).

If there is a contact, turn the brace pin upside down.

## MOWER BRACKET

If you have removed the original supports from the tractor, in order to install the mower brackets (item 19) inside the support; insert two hex. bolts 3/8 x 1 1/4" (item 20) (the heads on the outside) in the top holes of the right support .

From the inside of the support, place the shim (item 21; **notice orientation**) and the mower bracket (item 19) on the bolts. Secure with two flange nuts.

Do the same operation on the left side.

Tighten firmly.

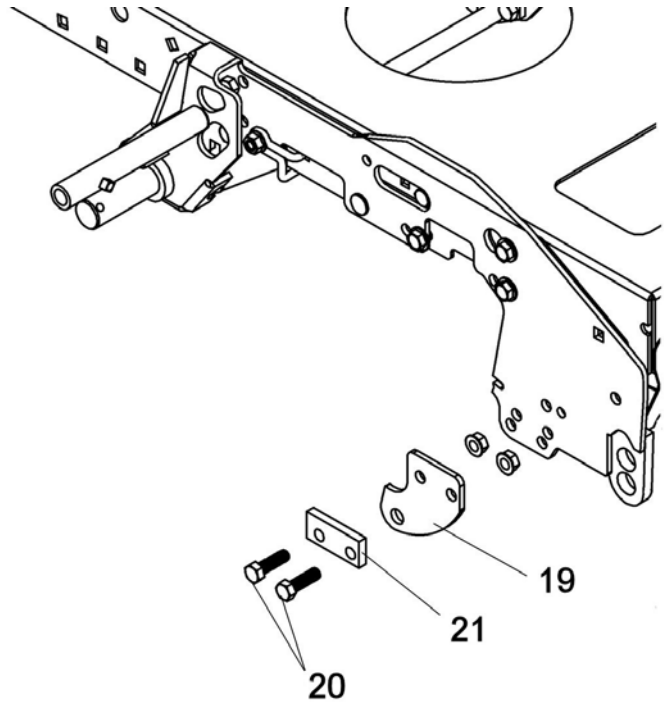

## Reinstall the parts:

Reinstall the parts previously removed in their original position.

Install the mower brackets inside the support and other parts if applicable.

# ASSEMBLY

## TRACTORS WITH A MANUAL CLUTCH ACTIVATED BY A CABLE:

If it is not possible to put back in place the tractor's belt guides, use the replacement belt guides supplied.

Insert the collars (item 1) on the brace pin (item 4). Tighten slightly. Place a belt guide (item 2) on each collar. Secure with a #10 x 24 x 3/4" machine screw (item 3) and nylon insert lock nut.

The belt guides must not touch the belt (item 5) when the drive mechanism is engaged.

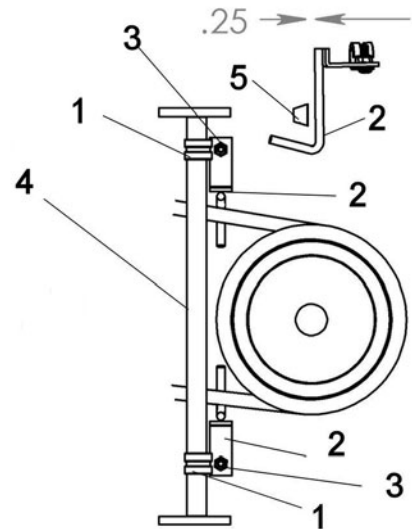

Install belt guide/drive mechanism engaged

When the drive mechanism is disengaged, the belt guides (item 6) must push enough on the belt (item 7) so that the drive mechanism pulley does not turn.

Tighten the collar screws and the nuts tightly.

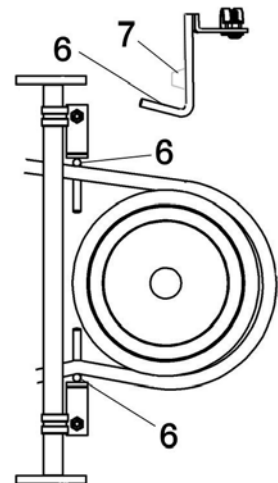

Drive mechanism disengaged



## WARNING



### TO PREVENT INJURIES:

It is the person who installs the belt guides responsibility to make sure that when the lawnmower is disengaged that all moving parts stop.

For more information, do not hesitate to contact the technical support.

# ASSEMBLY

**PIVOT SUPPORT:**

Turn the front wheels towards the right.  
 Install the pivot support (item 1) between the two supports and slide in place the pin (item 2) in the required holes. The other holes get the hooked end (item 5) of the pin. See table.

Tires	Holes in pivot support
15" x 6" or smaller	Top
16" x 6.5" or bigger	Bottom

Secure with the hair pin (item 3).  
 Tighten all the bolts.  
 If there is interference between the pivot support and the tractor heat shield, replace with the heat shield (item 4) supplied.

**NOTE:** If the original heat shield is bolted to the front of tractor frame, detach the top part (item 6) of the heat shield supplied by folding it up and down along the dotted line.

Be careful not to cut yourself on the sharp edges. For your safety sand down the sharp edges.

Use the tractor bolts to secure in place.

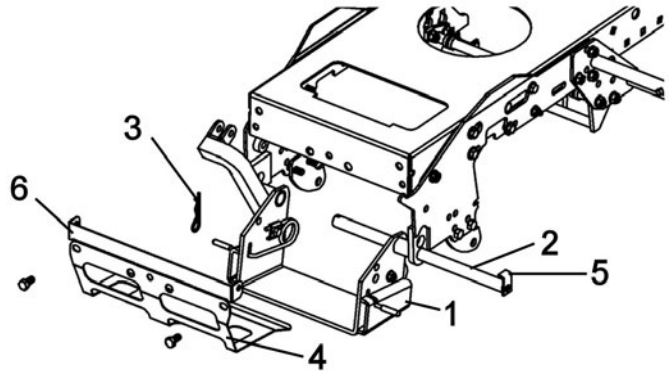

Install the pivot support.

**LIFT ARM:**

Insert the nylon bushings (item 1) in the lift arm (item 2).  
 Install the handgrip (item 3) on the lift arm as shown.

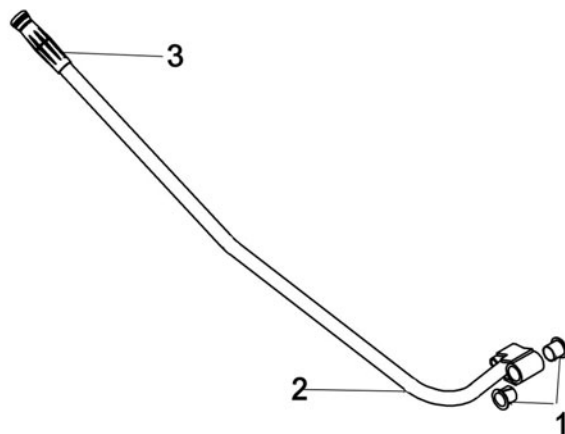

Assemble the lift arm

# ASSEMBLY

## LIFT MECHANISM:

Slide the link (item 1) inside the box of the right support (item 2). Insert the pin (item 3) inside the link.

Insert the lift arm (item 4) on the pin (item 5) of the right support and on the pin (item 3).

Secure the arm with one washer (item 6) and one hair pin 4 mm (item 7).

Secure the pin in place with a flat washer (item 8) and a hair pin 2.5 mm (item 9, **inserted from the bottom to the top**).

Secure the link to the pivot support (item 10) with a pin (item 11) and a hair pin 2.5 mm (item 12).

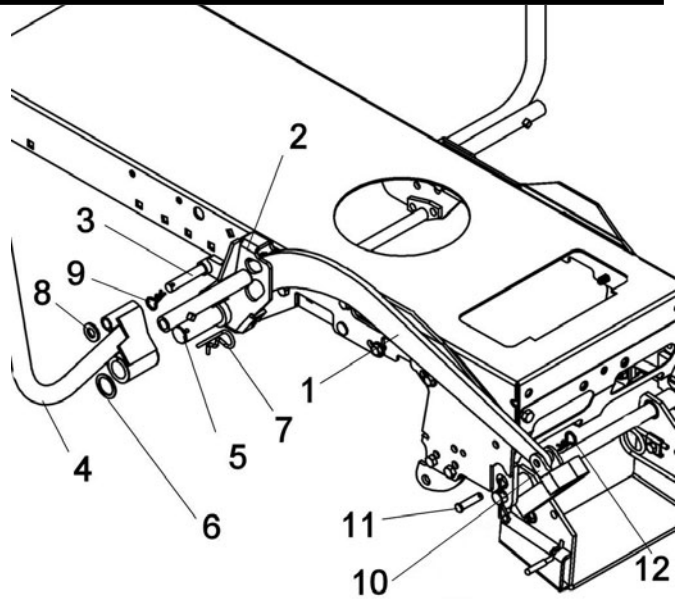

Install the lift mechanism

## STEP 3

### DRIVE MECHANISM PREPARATION:

#### SUPPORTS-GENERAL INSTALLATION:

Secure the left support (See table) with two carriage bolts 3/8" x 3/4" (item 3) heads outside. Secure with two flange nuts.

**NOTE: Install only one support on the right side.**

Side	Support
Left	104345 (item 2)
Right (If no interference with mower deck)	104345 (Item 2)
Right (If 104345 interferes with mower deck)	104346 (item 1)

On the right side, install the mounting support (item 4) inside the frame. Install on the outside (according to chart) the support (item 1 or 2), two washers 7/16" (item 5) and secure with two hair pins (item 6).

**NOTE:** On certain models of tractors, when the mower deck is lifted to its highest position, it comes into contact with the right hand support.

This installation will allow to remove the supports very easily at the end of the season.

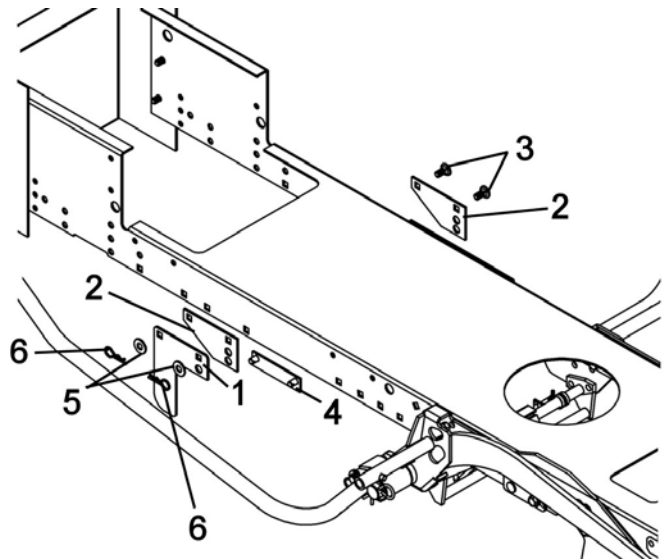

Install supports (General installation).

# ASSEMBLY

**NOTE:** If a bracket is installed on the outside of the lefthand side of the tractor frame:

- 1 Install the left support on the inside of the frame. Secure both bracket and left support to frame using hardware already mentioned.
- 2 Insert two flat washers 7/16" between the right support and the frame, **but only in this case.**

## SUPPORTS-VGT FRAME INSTALLATION:

To install the drive mechanism, you must remove the two bolts from the footrests (from each side).

Secure the left support (item 2) (longest support with point towards the front) and the right support (item 1) (shortest support with point towards the front) with the bolts removed from the footrests.

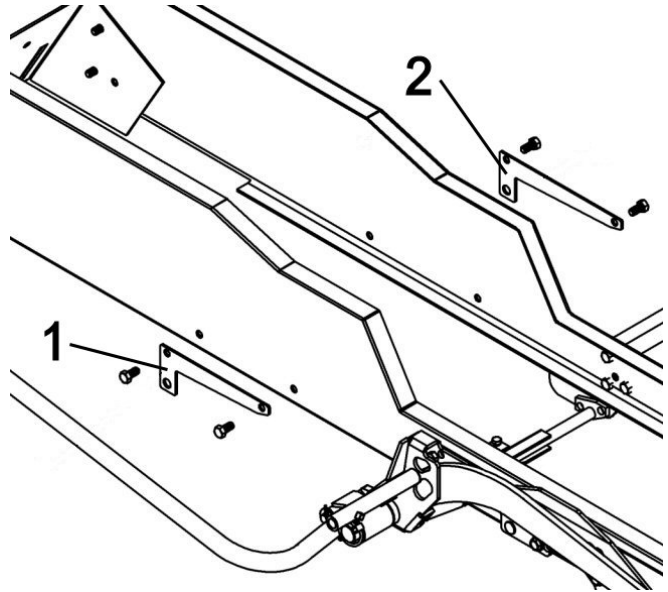

Install supports (VGT frame)

## **NOTE:**

- 1) This drive mechanism may be mounted on tractors with two types of clutch mechanisms. See the following instructions on the next pages for those that are appropriate for your tractor.
- 2) The mower deck must be removed to install / use the drive mechanism.

**NOTE: The drive mechanism must be straight, to make sure the belt works well.**

# ASSEMBLY

Use the following instructions to reposition the support (item 1) as needed.  
 To make the job easier, remove the spring (item 2).  
 Remove the support (item 1) by removing the two hex. bolts 1/4" x 1/2" (item 3).

Tractor	Position
2006 (most models, factory installed)	A
VGT frame	B
Others	C
2007 (most models tractors)	D

Place the support (item 1) in the required position according to chart, secure with the bolts (item 3) and tighten firmly.

**NOTE:** For position D, use the shim (item 4) and two 1/4 x 3/4" hex bolts supplied in the hardware bag.

Remove the flat pulley (item 5). Turn upside down and reposition the pulley as shown in A with the flat washers.

Reinstall the spring (item 2) in its original place.

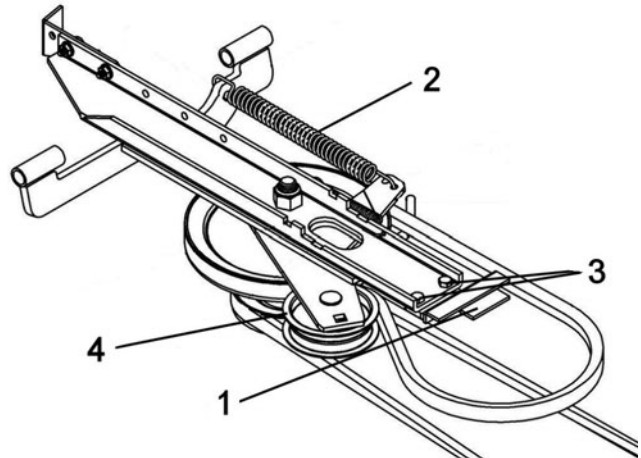

Remove and reinstall the spring

## Positions

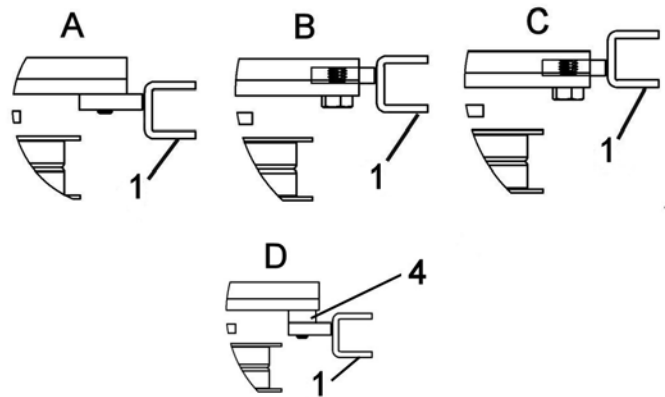

Reposition the support

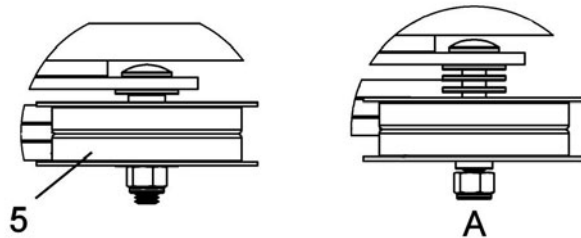

Reposition the pulley



# ASSEMBLY

## TRACTOR WITH AN ELECTRIC CLUTCH.

No modifications are needed.

## TRACTORS WITH A MANUAL CLUTCH ACTIVATED BY A CABLE.

Remove the spring that is hooked in holes (item 1) of idler arm (item 2) and drive frame (item 10).

Hook the spring of the tractor's cable (item 5) on the tension arm.

Cut the tie wrap that holds the cable to the frame.

**NOTE:** Depending on the mower deck model, there are different cable lengths. To determine where to place the cable holder (item 7), hook the end of the cable spring (item 5) on the idler arm (item 2). Slide the cable shield (item 6) temporarily into the slot on the cable holder (item 7). To identify into which holes the cable holder will be bolted in, you must apply a slight tension on the cable. This adjustment must be done with the clutch arm in the disengaged position.

Remove the cable shield and secure the cable holder (item 7) on the frame using two 1/4 x 3/4" hex bolts (item 8) and flange nuts. Reinstall the cable shield into the cable holder and secure with a 2mm hair pin (item 9).

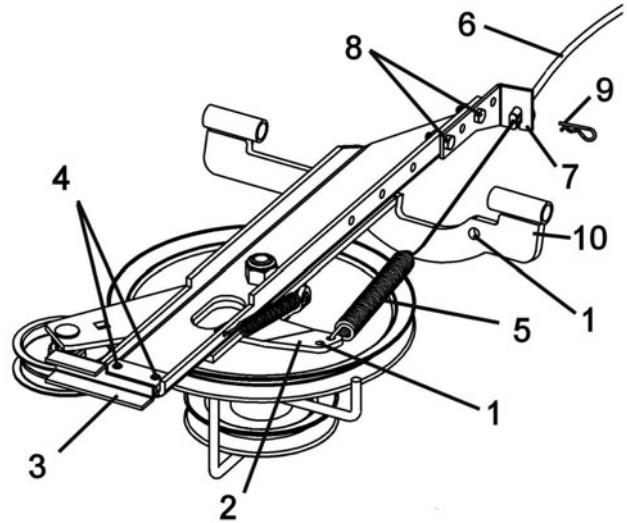

Install cable holder

# ASSEMBLY

## STEP 4

### DRIVE MECHANISM INSTALLATION:

**NOTE: You must remove mower deck to install the drive mechanism.**

Install the drive mechanism (item 1) by hooking the front part of the drive frame (item 2) on the brace pin (item 3).

Lift and attach the rear portion of the drive frame between the supports (items 4 or 5 or 6) by inserting a pin on each side. Select the correct holes using the chart.

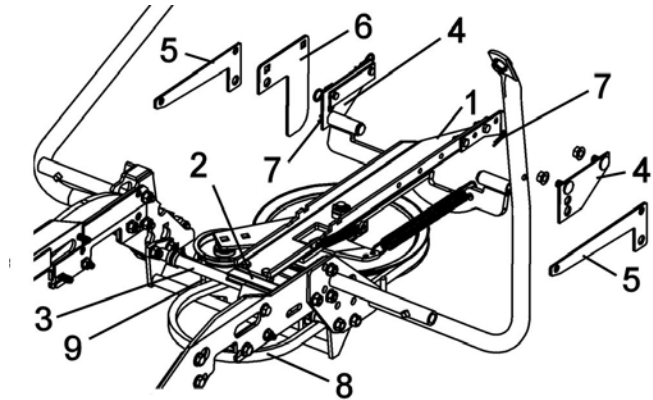

Support	Holes	Item #
104345 right side	Bottom	4
104346 left side	Top	6
104093 & 104094	Only one possibility	5

Install drive mechanism .

Secure with two 2.5 mm hair pins (item 7).  
Install the belt (item 8) on the engine pulley and route inside the belt guide (item 9).

### TRACTOR WITH A MANUAL CLUTCH ACTIVATED BY A CABLE

Readjust the belt-guides (item 2). If the belt guides are not installed yet, refer to **TRACTOR WITH A MANUAL CLUTCH ACTIVATED BY A CABLE OF STEP 2**

The belt guides (item 2) must not touch the belt (item 1) when the drive mechanism is engaged.

<span style="font-size: 1.5em; font-weight: bold; margin: 0 10px;">WARNING</span>
<p><b>TO PREVENT INJURIES:</b> It is the person who installs the drive mechanism responsibility to make sure that when the clutch is disengaged that all moving parts stop.</p>
<p><b>For more information, do not hesitate to contact the technical support.</b></p>

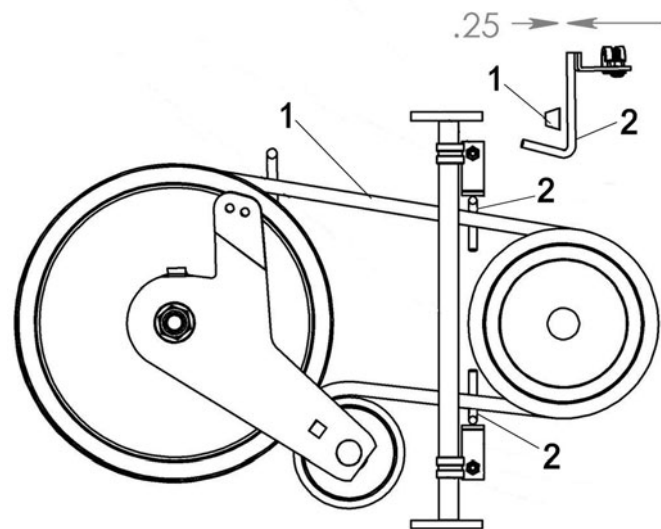

Adjust belt guides/ Drive mechanism engaged  
(View of top of drive mechanism)

## ASSEMBLY

When the drive mechanism is disengaged, the belt guides (item 4) must push enough on the belt (item 3) so that the drive mechanism pulley does not turn.

Tighten the collar screw and the nut tightly.

**NOTE:** After installation, attach the cable to the frame with the new tie wrap supplied with this kit.

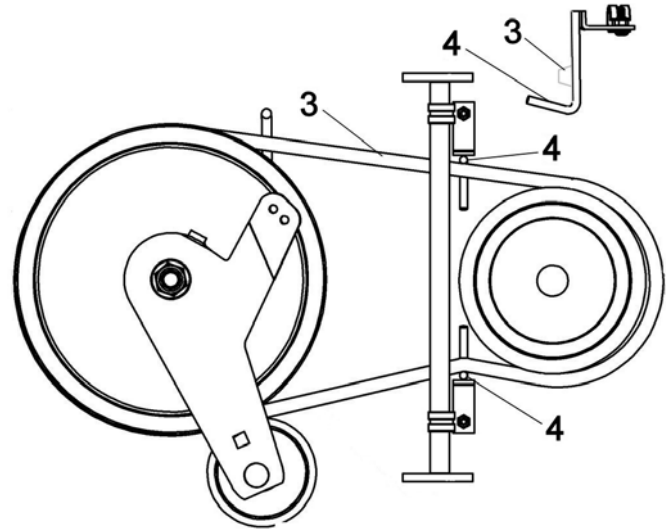

Drive mechanism disengaged



### WARNING



**TO PREVENT INJURIES DO THIS VERIFICATION WHEN THE ENGINE IS STOPPED.**

#### **BELT ALIGNMENT VERIFICATION:**

Make sure the drive mechanism pulley (item 1) is aligned with the engine pulley (item 2) within 1/4" If not, you may change the position of the support (104344) and / or the position of the rear pins as needed.

If the top edge of the belt touches the edge of the flat pulley (item 3), remove the flat washer (item 4).

#### **NOTE: Electric Clutch :**

If your tractor is equipped with an electric clutch, make sure the spring is well inserted in its place and the belt does not touch the belt guides at any point.

#### **NOTE: Manual Clutch:**

If your tractor is equipped with a manual clutch, make sure the belt guide does not touch the belt at any point while the drive mechanism is engaged.

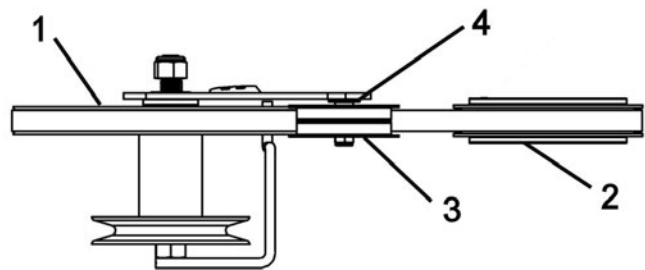

# ASSEMBLY

## STEP 5

### **SNOWBLOWER INSTALLATION:**

Refer to snowblower owner's manual, parts breakdown section for parts identification.



## WARNING



### **FOR YOUR SECURITY:**

Read the snowblower's owner's manual for safety precautions and rules.

Follow the assembly and operation instructions.

Attach the snowblower to the subframe as shown.

Make sure the snowblower is pushed in until locked into place by the springs (item 4).

Lift the snowblower by pulling the lift arm. Turn the tension arm (item 1) towards the back. Hook the chain (item 2) (of the helper spring) on the tip (item 3) of the left support intended for this purpose. Turn the tension arm towards the front to apply tension on the spring.

Lower the snowblower.



## WARNING



### **TO PREVENT INJURIES:**

Stop the motor.

Apply parking brake.

Remove the ignition key.

Disconnect the wire from the spark plug(s) and keep away from spark plug(s) to prevent accidental starting.

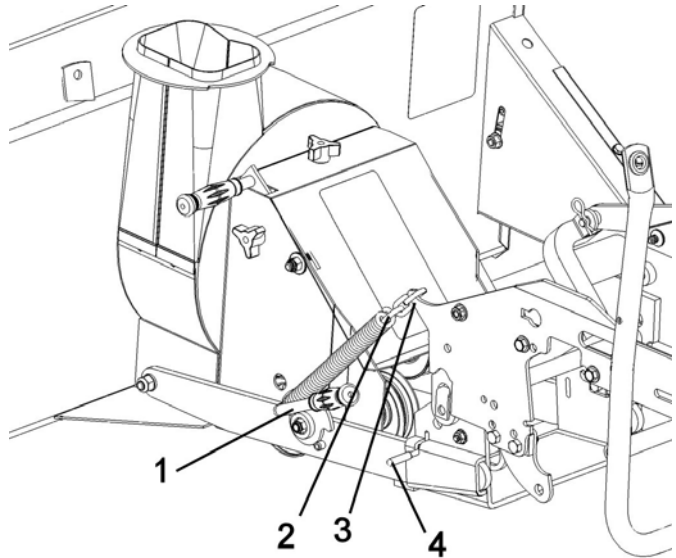

Install snowblower and lift assist spring



## CAUTION



The belt tension arm and lift assist spring are spring loaded & needs to be held firmly while displacing to prevent injury.



## WARNING



### **TO PREVENT INJURIES:**

It is the person who installs the drive mechanism responsibility to make sure that when the clutch is disengaged that all moving parts stop.

For more information, do not hesitate to contact the technical support.

**NOTE:** See belt installation instructions in the maintenance section of the snowblower owner's manual.



## CAUTION



Never use the snowblower without the belt guard.

## ASSEMBLY

Insert the handgrip (item 1) on the handle (item 2).  
Insert the handle (item 2) through the support (item 3)  
as shown.  
Insert the handle (item 2) in the rotation worm (item 5)  
and secure with a 2.5 mm. hair pin (item 4).

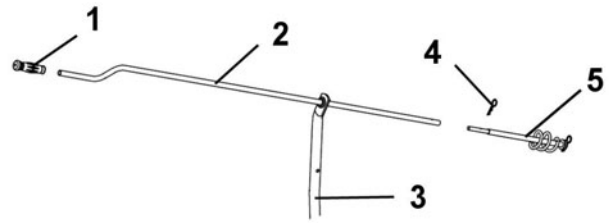

Install handle

### **VERIFY SKID SHOE ADJUSTMENT:**

**LEVEL PAVED SURFACE:** Adjust skid shoes to allow 3/16" to 1/4" clearance (A) between cutting edge and surface.

**UNEVEN OR GRAVEL SURFACE:** Adjust skid shoes to allow 1/2" to 5/8" clearance (A) between cutting edge and surface.

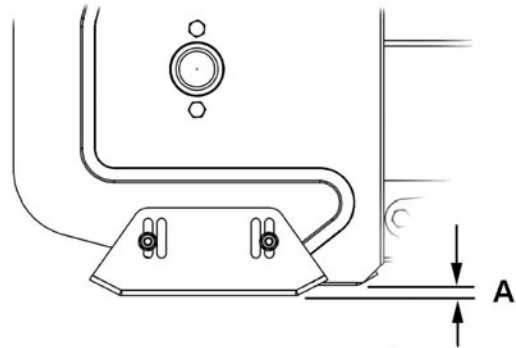

Adjust skid shoe

### **VERIFY TIRE PRESSURE:**

Check and adjust tractor tire pressure as follows:

Front tires: 14-15 psi

Back tires: 7-8 psi

Tire pressure must be even on both sides of tractor.

# ASSEMBLY

## ROTARY BROOM INSTALLATION:

Refer to rotary broom owner's manual, parts breakdown section for parts identification.



## WARNING



### FOR YOUR SECURITY:

Read the Rotary Broom owner's manual for safety precautions and rules.  
Follow the assembly and operation instructions.



## WARNING



### TO PREVENT INJURIES:

Stop the motor.  
Apply parking brake.  
Remove the ignition key.  
Disconnect the wire from the spark plug(s) and keep away from spark plug(s) to prevent accidental starting.

Attach the rotary broom to the subframe as shown.

Make sure the rotary broom is pushed in until locked into place by the springs (item 1).

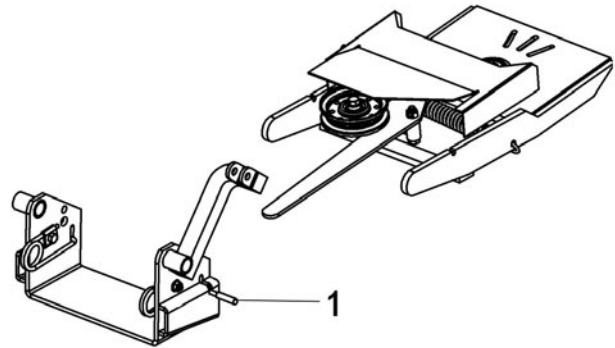

Install rotary broom



## CAUTION



Never use the Rotary Broom without the belt guard.

## BELT INSTALLATION

**NOTE:** See belt replacement instructions in the maintenance section of the owner's manual for the broom.

Remove the belt guard.

Install the belt on the drive mechanism pulley (item 1) as shown.

Reinstall the belt guard.

**TIP:** Because of strong tension on the spring and to facilitate installation of the belt, the broom must be on the ground and remove the belt from the engine pulley.

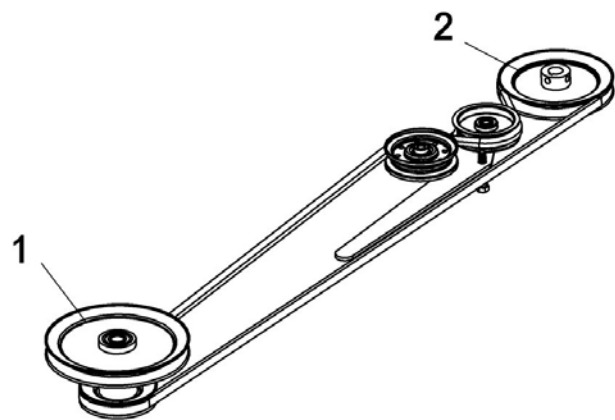

Item 1: Drive mechanism pulley  
Item 2: Rotary broom pulley

Install belt

# ASSEMBLY

## **VERIFY BELT ROUTING:**

- Lower the rotary broom to the ground and let it run for a few seconds under supervision.
- Disengage the rotary broom and stop the engine.
- Check the belts to make sure they are well inserted on the pulleys and have not flipped on their sides in the pulleys and that they do not touch the belt guides.



## **WARNING**



### **TO PREVENT INJURIES:**

**It is the person who installs the drive mechanism responsibility to make sure that when the clutch is disengaged that all moving parts stop.**

**For more information, do not hesitate to contact the technical support.**

Insert handgrip (item 5) on the handle (item 1).

Insert the handle (item 1) through the support (item 2) as shown.

Install the handle on the control rod (item 3) as shown and secure with a 2.5 mm. hair pin (item 4).

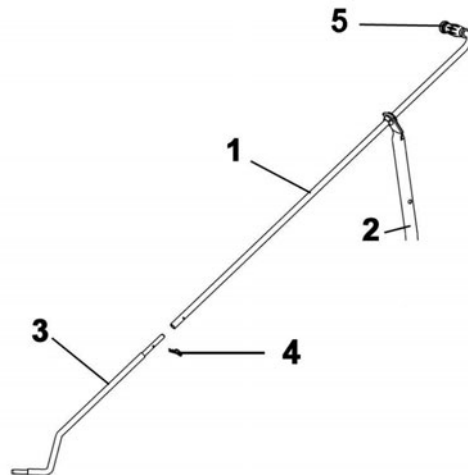

Install handle

## **VERIFY TIRE PRESSURE:**

Check and adjust tractor tire pressure as follows:

Front tires: 14-15 psi  
Back tires: 7-8 psi

Tire pressure must be even on both sides of the tractor.

# ASSEMBLY

## **BLADE INSTALLATION:**

Refer to blade owner's manual, parts breakdown section for parts identification.



## **WARNING**



### **FOR YOUR SECURITY:**

Read the Blade owner's manual for safety precautions and rules.  
Follow the assembly and operation instructions.

Attach the blade to the subframe as shown.

Make sure the blade is pushed in until locked into place by the springs (item 1).

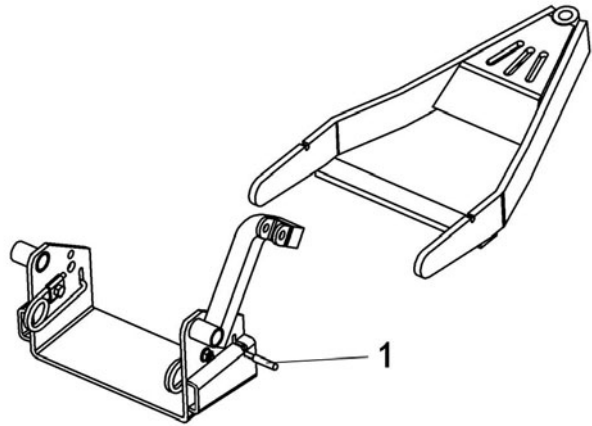

Install the blade

Insert the handgrip (item 5) on the handle (item 1).

Insert the handle (item 1) through the handle support (item 2) as shown.

Install the handle on the control rod (item 3) as shown and secure with a 2.5 mm hair pin (item 4).

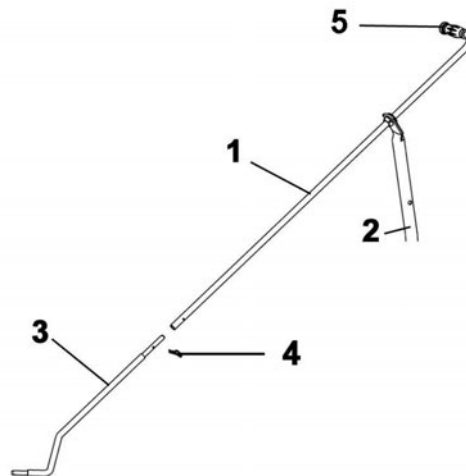

Install handle

## **VERIFY TIRE PRESSURE:**

Check and adjust tractor tire pressure as follows:

Front tires: 14-15 psi  
Back tires: 7-8 psi

Tire pressure must be even on both sides of the tractor.



# MAINTENANCE & DISMOUNTING

## **MAINTENANCE**

- a) Check mounting bolts at frequent intervals for proper tightness to be sure equipment is in safe working condition.
- b) Apply oil at all pivot points.

## **DRIVE MECHANISM DISMOUNTING**

**SEE ATTACHMENT OWNER'S MANUAL (SNOWBLOWER, BROOM AND BLADE) FOR DISMOUNTING INSTRUCTIONS.**

- a) Dismount the attachment.
- b) Remove the rear counterweight when you remove the front attachment.
- c) Dismount the drive mechanism by supporting it in hand and removing the two hair pins and the pins. Carefully lower to the ground. Remove the V-belt from engine pulley.

### Manual clutch activated by cable:

Unhook cable shield by removing the hair pin. Unhook spring. Pull out drive mechanism from underneath tractor.

- d) On certain models of tractors, when the mower deck is lifted to its highest position, it comes into contact with the right hand support. Remove the supports by removing the hair pins and washers. Store these parts with the drive mechanism for the next season.
- e) You may leave the subframe on tractor all year long or remove it if preferred.
- f) Reinstall mower if needed.

## **BELT REPLACEMENT**

### **Drive Mechanism Belt:**

Dismount the drive mechanism.

Remove the bolt which retains the tension pulley. Replace the belt and re-install the tension pulley. Before tightening make sure the belt guide does not touch the belt at any time. Re-install the drive mechanism.

### Manual Clutch:

With the engine stopped, engaged and disengage the clutch and make sure the belt does not come into contact with the belt guide (104095/104043).

### Electric Clutch:

Make sure the belt does not come into contact with the belt guide (104095/104043)

## **END OF SEASON STORAGE**

- a) Clean and paint all parts from which paint has worn.
- b) Apply oil at all pivot points.
- c) Inspect and replace all defective parts before using again.

# PARTS BREAKDOWN

## COMPACT DRIVE MECHANISM #700414-2

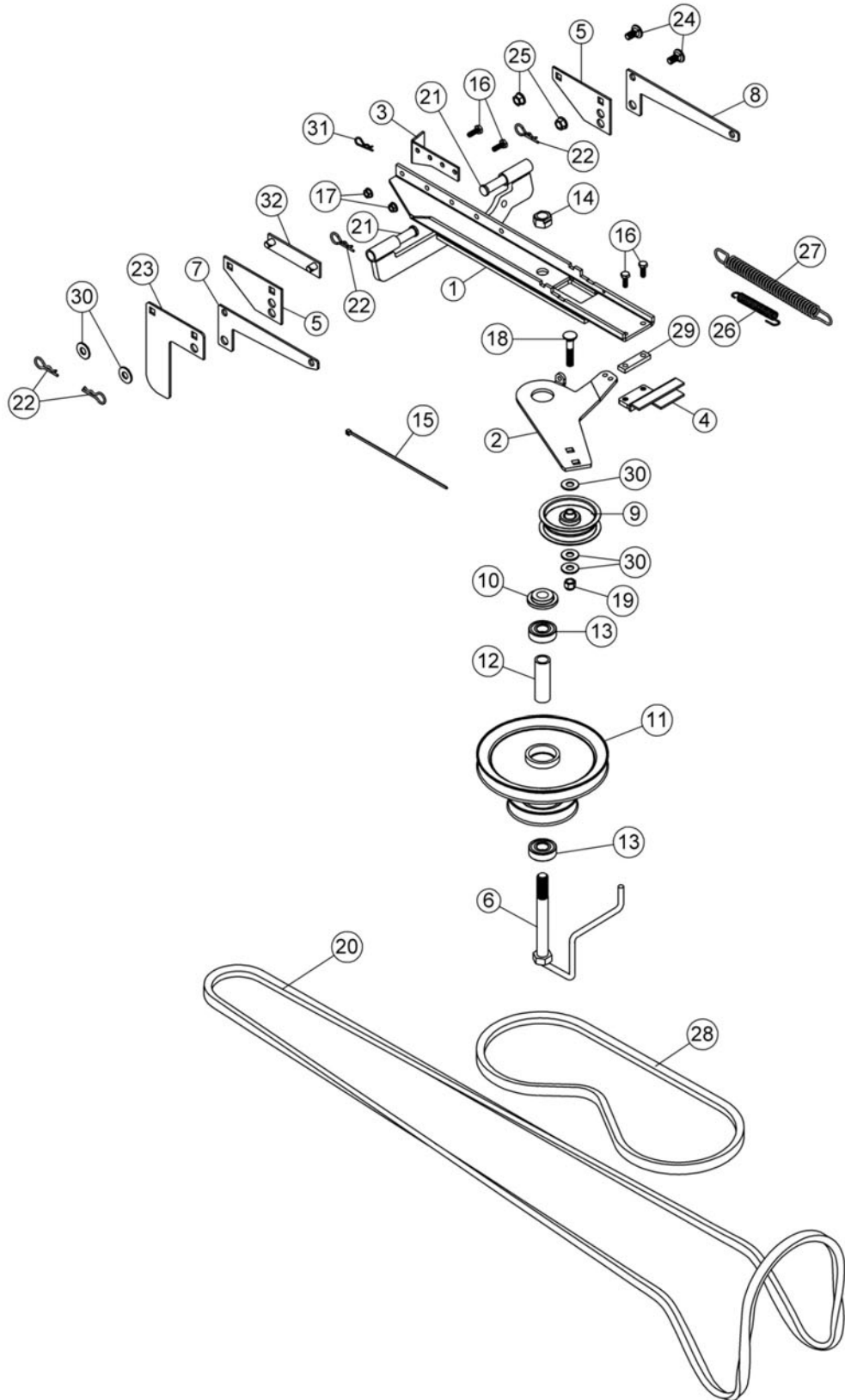

## PARTS LIST

### COMPACT DRIVE MECHANISM #700414-2

Ref. Réf.	English description	Description française	Qty. Qté.	Part # Pièce #
1	Drive frame	Châssis d'entraînement	1	104343
2	Idler arm	Bras de tension	1	104347
3	Cable holder	Fixation du câble	1	104092
4	Support	Support	1	104344
5	Support	Support	2	104345
6	Belt guide	Guide-courroie	1	104095
7	Right support	Support droit	1	104093
8	Left support	Support gauche	1	104094
9	Flat pulley	Poulie plate	1	102839
10	Flange washer	Rondelle à bride	1	102969
11	Double pulley inc. 102736 & 102782	Poulie double inc. 102736 & 102782	1	102692
12	Sleeve	Douille	1	102782
13	Ball bearing	Roulement à billes	2	102736
14	Stover lock nut 5/8" n.c.	Écrou de blocage 5/8" n.c.	1	O/L
15	Tie wrap 8"	Attache de nylon 8"	1	O/L
16	Hex. bolt 1/4" n.c. x 3/4"	Boulon hex. 1/4" n.c. x 3/4"	4	O/L
17	Flange nut 1/4" n.c.	Écrou à bride 1/4" n.c.	2	O/L
18	Carriage bolt 3/8" n.c. x 2"	Boulon à carrosserie 3/8" n.c. x 2"	1	O/L
19	Nylon insert lock nut 3/8" n.c.	Écrou à garniture de nylon 3/8" n.c.	1	O/L
20	V-Belt B-112	Courroie en V B-112	1	103010
21	Pin	Goupille	2	102189
22	Hair pin 2.5mm	Goupille à ressort 2.5mm	4	102013
23	Right support	Support droit	1	104346
24	Carriage bolt 3/8" n.c. x 3/4"	Boulon à carrosserie 3/8" n.c. x 3/4"	2	O/L
25	Flange nut 3/8" n.c.	Écrou à bride 3/8" n.c.	2	O/L
26	Spring 1/2"	Ressort 1/2"	1	102003
27	Spring	Ressort	1	102304
28	V-Belt A-46	Courroie en V A-46	1	104133
29	Shim	Cale	1	104668
30	Flat washer 7/16" hole	Rondelle plate 7/16" trou	5	O/L
31	Hair pin 2mm	Goupille à ressort 2mm	1	102430
32	Mounting support	Support montage	1	104667

O/L = Obtain Locally

# PARTS BREAKDOWN

## NORTHEAST DRIVE MECHANISM #700415-2

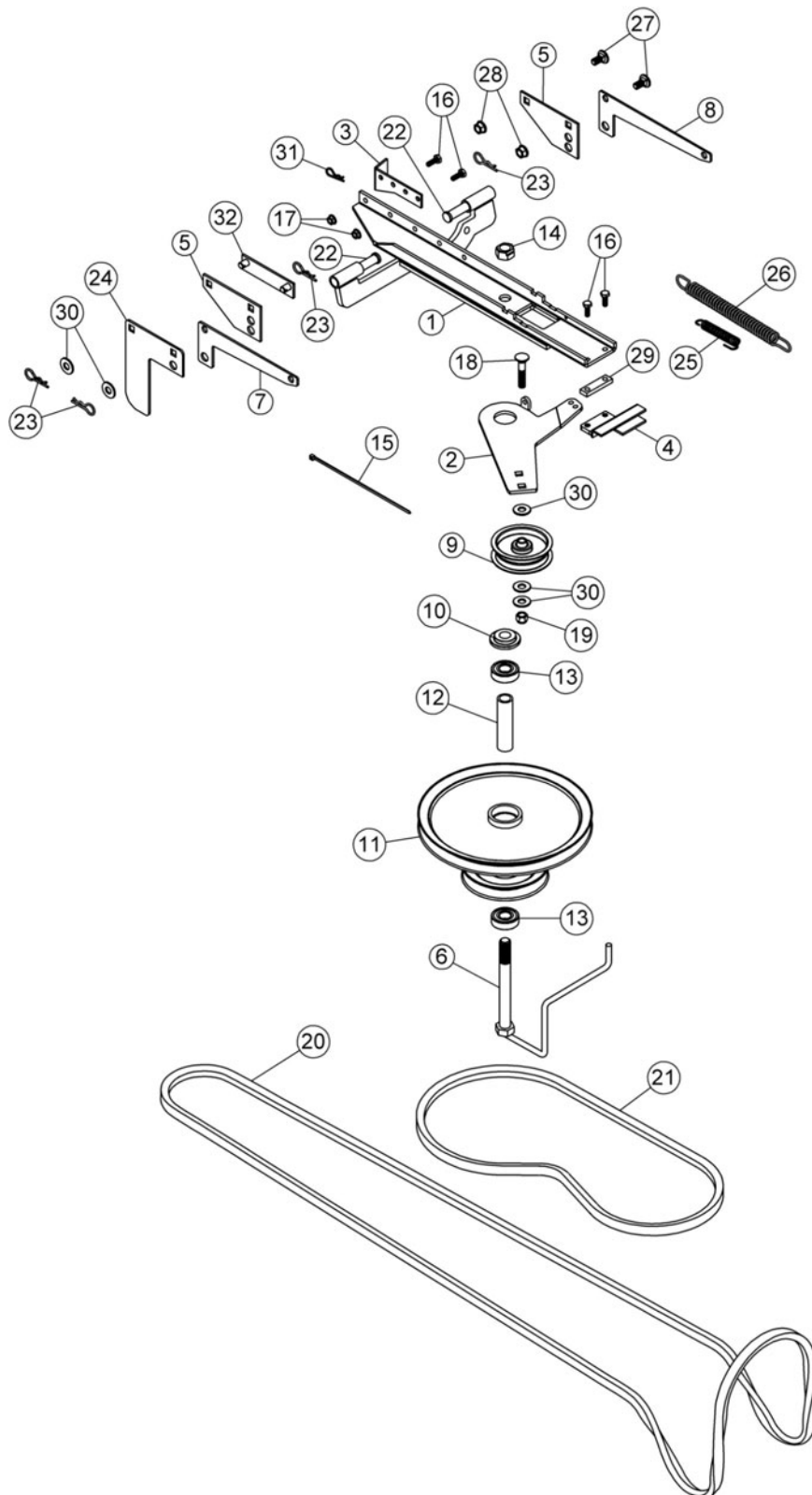

## PARTS LIST

### NORTHEAST DRIVE MECHANISM 700415-2

Ref. Réf.	English description	Description française	Qty. Qté.	Part # Pièce #
1	Drive frame	Châssis d'entraînement	1	104343
2	Idler arm	Bras de tension	1	104347
3	Cable holder	Fixation du câble	1	104092
4	Support	Support	1	104344
5	Support	Support	2	104345
6	Belt guide	Guide-courroie	1	104043
7	Right support	Support droit	1	104093
8	Left support	Support gauche	1	104094
9	Flat pulley	Poulie plate	1	102839
10	Flange washer	Rondelle à bride	1	102969
11	Double pulley inc. 102736 & 103035	Poulie double inc. 102736 & 103035	1	103040
12	Sleeve	Douille	1	103035
13	Ball bearing	Roulement à billes	2	102736
14	Stover lock nut 5/8" n.c.	Écrou de blocage 5/8" n.c.	1	O/L
15	Tie wrap 8"	Attache de nylon 8"	1	O/L
16	Hex. bolt 1/4" n.c. x 3/4"	Boulon hex. 1/4" n.c. x 3/4"	4	O/L
17	Flange nut 1/4" n.c.	Écrou à bride 1/4" n.c.	2	O/L
18	Carriage bolt 3/8" n.c. x 2"	Boulon à carrosserie 3/8" n.c. x 2"	1	O/L
19	Nylon insert lock nut 3/8" n.c.	Écrou à garniture de nylon 3/8" n.c.	1	O/L
20	V-Belt, B-118	Courroie en V, B-118	1	104044
21	V-Belt, A-50	Courroie en V, A-50	1	104104
22	Pin	Goupille	2	102189
23	Hair pin 2.5mm	Goupille à ressort 2.5mm	4	102013
24	Right support	Support droit	1	104346
25	Spring 1/2"	Ressort 1/2"	1	102003
26	Spring	Ressort	1	102304
27	Carriage bolt 3/8" n.c. x 3/4"	Boulon à carrosserie 3/8" n.c. x 3/4"	2	O/L
28	Flange nut 3/8" n.c.	Écrou à bride 3/8" n.c.	2	O/L
29	Shim	Cale	1	104668
30	Flat washer 7/16" hole	Rondelle plate 7/16" trou	5	O/L
31	Hair pin 2mm	Goupille à ressort 2mm	1	102430
32	Mounting support	Support montage	1	104667

O/L = Obtain Locally

# PARTS BREAKDOWN SUBFRAME #700413-3

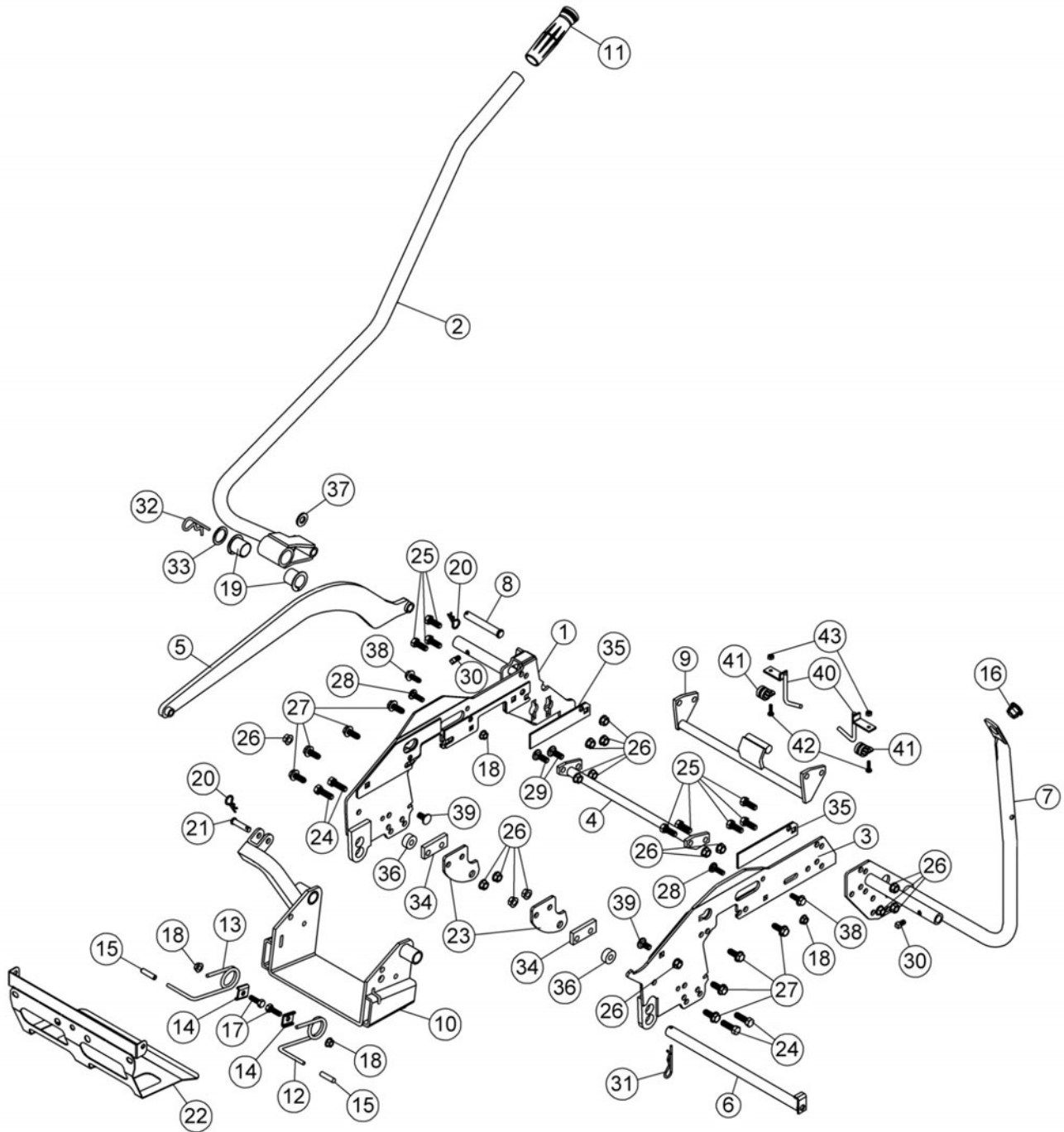

## PARTS LIST SUBFRAME #700413-3

Ref. Réf.	English description	Description française	Qty. Qté.	Part # Pièce #
1	Right support	Support droit	1	104332
2	Lift arm	Bras de relevage	1	104336
3	Left support	Support gauche	1	104331
4	Brace pin	Tige de renfort	1	104334
5	Link	Lien	1	104335
6	Pin	Goupille	1	104340
7	Handle support	Support de manivelle	1	104333
8	Pin	Goupille	1	104337
9	Brace pin	Tige de renfort	1	104533
10	Pivot support	Support de pivot	1	104330
11	Handgrip	Poignée de plastique	1	102025
12	Left spring lock	Ressort de barrure gauche	1	102208
13	Right spring lock	Ressort de barrure droit	1	102209
14	Spring bracket	Fixation du ressort	2	102210
15	Handgrip	Poignée	2	102248
16	Plastic grommet	Oeillet de plastique	1	102063
17	Hex. bolt 5/16" n.c. x 1"	Boulon hex. 5/16" n.c. x 1"	2	O/L
18	Flange nut 5/16" n.c.	Écrou à bride 5/16" n.c.	4	O/L
19	Nylon bushing	Coussinet en nylon	2	103087
20	Hair pin 2.5mm	Goupille à ressort 2.5mm	2	102013
21	Pin	Goupille	1	102772
22	Heat shield	Pare-chaleur	1	104669
23	Mower bracket	Fixation de tondeuse	2	103113
24	Hex. bolt 3/8" n.c. x 1 1/4"	Boulon hex. 3/8" n.c. x 1 1/4"	4	O/L
25	Hex. bolt 3/8" n.c. x 1"	Boulon hex. 3/8" n.c. x 1"	8	O/L

**O/L = Obtain Locally**

## PARTS LIST SUBFRAME #700413-3

Ref. Réf.	English description	Description française	Qty. Qté.	Part # Pièce #
26	Flange nut 3/8" n.c.	Écrou à bride 3/8" n.c.	16	O/L
27	Thread cutting screw 3/8" n.c. x 1"	Vis a filetage coupante 3/8" n.c. x 1"	8	O/L
28	Carriage bolt 5/16" n.c. x 1"	Boulon à carrosserie 5/16" n.c. x 1"	2	O/L
29	Carriage bolt 3/8" n.c. x 1"	Boulon à carrosserie 3/8" n.c. x 1"	2	O/L
30	Square head set screw 5/16" n.c. x 1/2"	Vis à pression à tête carrée 5/16" n.c. x 1/2"	2	O/L
31	Hair pin 3mm	Goupille à ressort 3mm	1	102617
32	Hair pin 4mm	Goupille à ressort 4mm	1	102054
33	Washer	Rondelle	1	104339
34	Shim	Cale	2	104120
35	Shim	Cale	2	104121
36	Spacer	Espaceur	2	104091
37	Washer	Rondelle	1	104122
38	Thread cutting screws 5/16" n.c. x 1"	Vis a filetage coupante 5/16" n.c. x 1"	2	O/L
39	Carriage bolt 3/8" n.c. x 3/4"	Boulon à carrosserie 3/8" n.c. x 3/4"	2	O/L
40	Belt guide	Guide-courroie	2	104348
41	Collar	Collet	2	104349
42	Machine screw P.H. #10 x 24 x 3/4"	Vis mécanique P.H. #10 x 24 x 3/4"	2	O/L
43	Nylon insert lock nut #10 x 24	Écrou à garniture de nylon #10 x 24	2	O/L

**O/L = Obtain Locally**



# TORQUE SPECIFICATION TABLE

## GENERAL TORQUE SPECIFICATION TABLE USE THE FOLLOWING TORQUES WHEN SPECIAL TORQUES ARE NOT GIVEN

**NOTE:** These values apply to fasteners as received from supplier, dry or when lubricated with normal oil. They do not apply if special graphited or moly disulphide greases or other extreme pressure lubricants are used. This applies to both UNF and UNC threads.

\* Thick nuts must be used with grade 8 bolts

SEE Grade No.		2				5				8 *			
BOLT HEAD IDENTIFICATION MARKS AS PER GRADE NOTE MANUFACTURING MARKS WILL VARY		TORQUE				TORQUE				TORQUE			
BOLT SIZE		FOOT POUNDS		NEW TON-METERS		FOOT POUNDS		NEW TON-METERS		FOOT POUNDS		NEW TON-METERS	
Inches	Millimetre	Min.	Max.	Min.	Max.	Min.	Max.	Min.	Max.	Min.	Max.	Min.	Max.
1/4"	6.35	5	6	6.8	8.13	9	11	12.2	14.9	12	15	16.3	30.3
5/16"	7.94	10	12	13.6	16.3	17	20.5	23.1	27.8	24	29	32.5	39.3
3/8"	9.53	20	23	27.1	31.2	35	42	47.5	57	45	54	61	73.2
7/16"	11.11	30	35	40.7	47.4	54	64	73.2	86.8	70	84	94.9	113.9
1/2"	12.7	45	52	61	70.5	80	96	108.5	130.2	110	132	149.2	179
9/16"	14.29	65	75	88.1	101.6	110	132	149.2	179	160	192	217	260.4
5/8"	15.88	95	105	128.7	142.3	150	180	203.4	244.1	220	264	298.3	358
3/4"	19.05	150	185	203.3	250.7	270	324	366.1	439.3	380	456	515.3	618.3
7/8"	22.23	160	200	216.8	271	400	480	542.4	650.9	600	720	813.6	976.3
1"	25.4	250	300	338.8	406.5	580	696	786.5	943.8	900	1080	1220.4	1464.5

METRIC BOLT TORQUE SPECIFICATIONS							
		COARSE THREAD			FINE THREAD		
Size Screw	Grade No.	Pitch (mm)	Foot Pounds	Newton-Meters	Pitch (mm)	Foot Pounds	Newton-Meters
M6	4T	1.00	3.6 - 5.8	4.9 - 7.9	-	-	-
	7T		5.8 - 9.4	7.9 - 12.7		-	-
	8T		7.2 - 10	9.8 - 13.6		-	-
M8	4T	1.25	7.2 - 14	9.8 - 19	1.00	12 - 17	16.3 - 23
	7T		17 - 22	23 - 29.8		19 - 27	25.7 - 36.6
	8T		20 - 26	27.1 - 35.2		22 - 31	29.8 - 42
M10	4T	1.50	20 - 25	27.1 - 33.9	1.25	20 - 29	27.1 - 39.3
	7T		34 - 40	46.1 - 54.2		35 - 47	47.4 - 63.7
	8T		38 - 46	51.5 - 62.3		40 - 52	54.2 - 70.5
M12	4T	1.75	28 - 34	37.9 - 46.1	1.25	31 - 41	42 - 55.6
	7T		51 - 59	69.1 - 79.9		56 - 68	75.9 - 92.1
	8T		57 - 66	77.2 - 89.4		62 - 75	84 - 101.6
M14	4T	2.00	49 - 56	66.4 - 75.9	1.50	52 - 64	70.5 - 86.7
	7T		81 - 93	109.8 - 126		90 - 106	122 - 143.6
	8T		96 - 109	130.1 - 147.7		107 - 124	145 - 168
M16	4T	2.00	67 - 77	90.8 - 104.3	1.50	69 - 83	93.5 - 112.5
	7T		116 - 130	157.2 - 176.2		120 - 138	162.6 - 187
	8T		129 - 145	174.8 - 196.5		140 - 158	189.7 - 214.1
M18	4T	2.00	88 - 100	119.2 - 136	1.50	100 - 117	136 - 158.5
	7T		150 - 168	203.3 - 227.6		177 - 199	239.8 - 269.6
	8T		175 - 194	237.1 - 262.9		202 - 231	273.7 - 313
M20	4T	2.50	108 - 130	146.3 - 176.2	1.50	132 - 150	178.9 - 203.3
	7T		186 - 205	252 - 277.8		206 - 242	279.1 - 327.9
	8T		213 - 249	288.6 - 337.4		246 - 289	333.3 - 391.6

# ATTACHMENTS

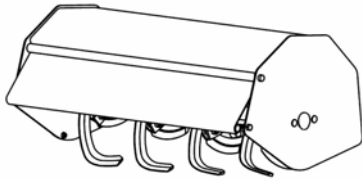

**ROTARY TILLER #700312**

Mounts to the rear of lawn, yard & garden tractors 14 to 25 HP. Comes complete with drive & manual lift mechanisms & mounting hardware.

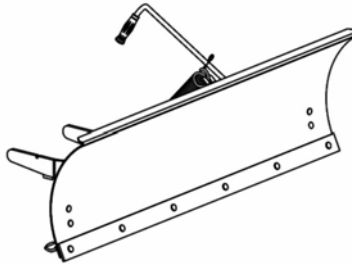

**UTILITY BLADE #700266**

Mounts on the same subframe as the snowblower & rotary broom.

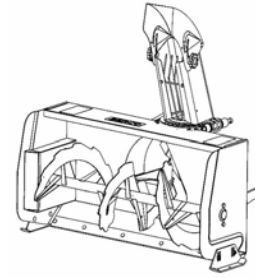

**SNOWBLOWER**

#700255-40"  
#700374-44"  
#700378-48"

Fits on same subframe as rotary broom and utility blade.

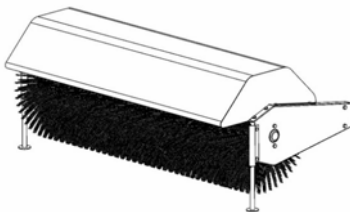

**ROTARY BROOM**

#700380 with nylon brush  
#700381 with polypropylene brush.

Fits on same subframe as snowblower & utility blade. Requires an adaptor.

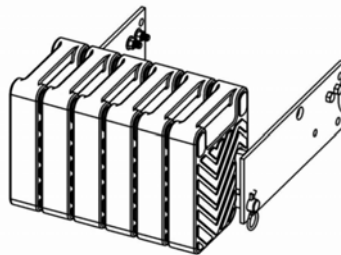

**COUNTERWEIGHT**

#700240 Universal rear weights  
#700246 Rear weights Electrolux  
Required for safety and traction. Counterbalances weight of attachment.

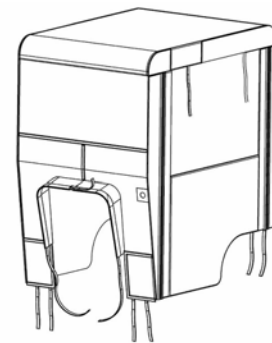

**TRACTOR WINTER CAB #700423**

Universal type fits on a wide variety of lawn and garden tractors.

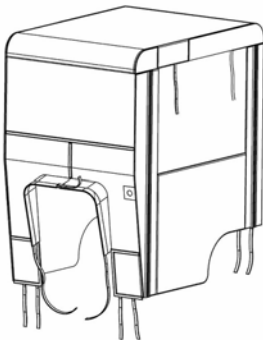

**TRACTOR SCREEN CAB #700424**

Universal type fits on a wide variety of lawn and garden tractors.

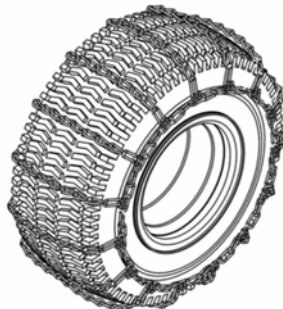

**TIRE CHAINS**

Two link spacing. Required for traction and safety. Pkg. of 2

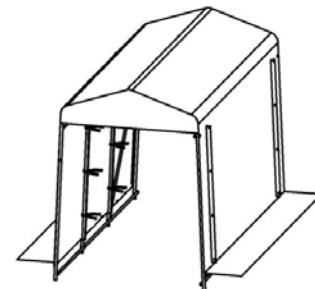

**WINTER SHELTER #700438**

Perfect to protect the tractors, A.T.Vs and snowmobiles from the weather. Dimensions: 5'W x 12'L x 7' 8"H





***WHEN PERFORMANCE  
& DEPENDABILITY  
ARE NON NEGOTIABLE!***

Bercomac Limitée  
92, Fortin North, Adstock, Quebec, Canada, G0N 1S0

*WWW.BERCOMAC.COM*

PRINTED IN CANADA

(ORIGINAL NOTICE)