

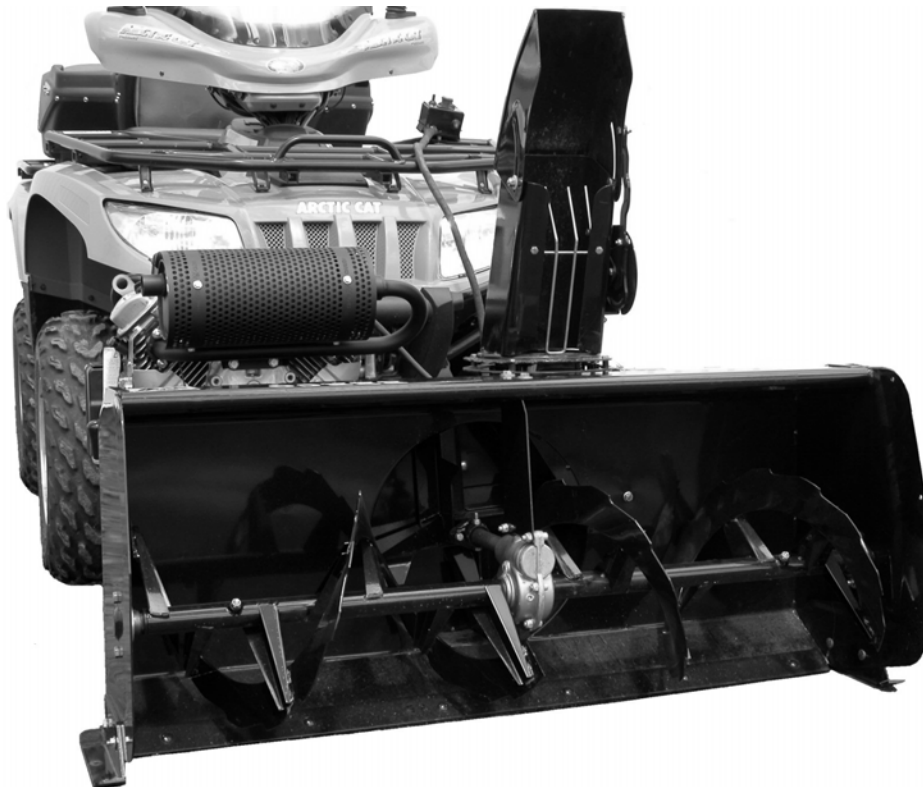

OWNER'S MANUAL
Model Number

700460-3



BERCO
VERSATILE 54" Snowblower
For
ALL TERRAIN VEHICLES & UTILITY VEHICLES

- * ASSEMBLY
- * OPERATION

- * REPAIR PARTS
- * MAINTENANCE

CAUTION:
**READ & FOLLOW ALL SAFETY RULES & INSTRUCTIONS BEFORE
OPERATING YOUR EQUIPMENT**



LIMITED WARRANTY

Conditions and Products Covered:

BERCOMAC guarantees any part of the product or accessory manufactured by BERCOMAC and found in the reasonable judgment of BERCOMAC to be defective in material and or workmanship will be repaired or replaced by an authorized dealer without charge up to our maximum labor rates and pre-established times. For replacement parts only standard ground freight services are covered. This warranty extends to the original retail purchaser only and is not transferable to any subsequent purchasers.

Warranty Period

(from date of the original retail purchase):

- Residential use: 1 year
- Semi- commercial, professional or rental use: 90 days

Exceptions Noted Below; the following items are guaranteed by the original manufacturer and have their own warranty, conditions and limited time:

- Tire Chains: 90 days
- Engines: Will vary as per the manufacturer
Please refer to the engine manufacturer's warranty statement included with the unit. BERCOMAC is not authorized to handle warranty adjustments on engines.

Items and Conditions NOT Covered:

This warranty does not cover the following:

- Pick-up or delivery charges or in-home services fees.
- Any damage or deterioration of the unit, parts and or finish of these due to normal use, wear and tear, or exposure.
- Cost of regular use or maintenance service or parts, such as gas, oil, lubricants, tune-up parts, and adjustments.
- Any part or accessory which has been altered, modified, misused, neglected, accidentally damaged or not properly installed, maintained, stored or repaired not in accordance with the instructions in the owner's manual.
- Repair due to normal wear and or any wear items such as shear pins, bolts, belts, etc.
- Expedited freight fee services for replacement parts.
- Shear bolts and shear pins are to be considered as a preventive measure not as an assured protection, any damages resulting from the lack of shear bolts breakage are not covered.

NOTE: All warranty work must be performed by an authorized dealer using original (manufacturer) replacement parts.

NOTE: Bercomac reserves the right to change or improve the design of any part or accessory without assuming any obligation to modify any product previously manufactured.

Instructions for Obtaining Warranty Services:

Contact dealer where equipment was purchased or any other authorized service dealer to arrange service at their dealership. Requests for warranty claims must be carried out through the same distribution network used to purchase the product. Don't forget to bring the product and your proof of purchase (sales receipt) to the dealer.

Owner's Responsibilities:

Any defective equipment or part must be returned to an authorized dealer within the warranty period for repairs. In the event that defective merchandise must be returned to manufacturer for repairs, the dealer must first obtain a written authorization from either KIMPEX or BERCOMAC, freight fees are prepaid prior to the shipment. This warranty extends only to equipment operated under normal conditions. To validate a warranty claim, it is the user's responsibility to maintain and service the unit as specified in the owner's manual or to have the unit serviced at their dealer at their expense.

General Conditions:

The sole liability of BERCOMAC with respect to this warranty shall be strictly and exclusively repair and replacement as mentioned herein. BERCOMAC shall not have any liability for any other costs, loss or damage, including but not limited to, any incidental or consequential loss or damage.

In particular, without being limited to, BERCOMAC shall have no liability or responsibility for:

- Travel time, overtime, after hours time or other extraordinary repair charges or relating to repairs and or replacements outside of normal business hours.
- Rental of like or similar replacement equipment during the period of any, repair or replacement work.
- Any communicating or travel charges.
- Loss or damage to person or property other than that covered by the terms of this warranty.
- Any claims for lost revenue, lost profit or any similar costs as a result of damage or repair.
- Attorney's fees.

BERCOMAC's responsibility in respect to claims is limited to making the required repairs or replacement without charge up to our maximum labor rates and pre-established times and no claim of breach of warranty shall be cause for cancellation or rescission of the contract of sale of any product or accessory.

This warranty gives you specific legal rights. You may also have other rights, which vary from state to state.

TABLE OF CONTENTS

	PAGE
INTRODUCTION	2
SAFETY PRECAUTIONS	3
SAFETY DECALS	5
ASSEMBLY	
Tools Required	6
Step 1: Snowblower Preparation	7
Step 2: Engine Installation	8
Step 3: Subframe Preparation	11
Step 4: Vehicle Preparation	11
Step 5: Control Box Installation	15
Step 6: Final Adjustments	18
OPERATION	
Operating the Snowblower	20
Electrical Controls	20
Removing Snow	20
Clearing a Clogged Discharge Chute	20
MAINTENANCE	
Maintenance	21
Adjustments	21
Lubrication	21
Cutting Edge Maintenance	21
Auger and Fan Shear Bolt Replacement	21
Snowblower Pulley Replacement or Alignment	21
Dismounting	21
Storage	21
BELT REPLACEMENT	22
REPLACEMENT OF ONE OR TWO SECTIONS OF THE AUGER AND / OR GEAR BOX	23
DISMOUNTING & STORAGE	24
TROUBLESHOOTING	25
PARTS BREAKDOWN AND PARTS LIST	
Rotation System with Chute	26
Subframe	28
Snowblower	30
TORQUE SPECIFICATION TABLE	34
OPTIONS & ACCESSORIES	35

INTRODUCTION

TO THE PURCHASER

This new accessory was carefully designed to give years of dependable service. This manual has been provided to assist in the safe operation and servicing of your attachment.

NOTE: All photographs and illustrations in the manual may not necessarily depict the actual models or attachment, but are intended for reference only and are based on the latest product information available at the time of publication.

Familiarize yourself fully with the safety recommendations and operating procedures before putting the machine to use. Carefully read, understand and follow these recommendations and insist that they be followed by those who will use this attachment.



THIS SAFETY ALERT SYMBOL IDENTIFIES AN IMPORTANT SAFETY MESSAGE IN THIS MANUAL THAT HELPS YOU AND OTHERS AVOID PERSONAL INJURY OR EVEN DEATH. DANGER, WARNING, AND CAUTION ARE SIGNAL WORDS USED TO IDENTIFY THE LEVEL OF HAZARD. HOWEVER, REGARDLESS OF THE HAZARD, BE EXTREMELY CAREFUL.

DANGER: Signals an extreme hazard that will cause serious injury or death if recommended precautions are not followed.

WARNING: Signals a hazard that may cause serious injury or death if the recommended precautions are not followed.

CAUTION: Signals a hazard that may cause minor or moderate injury if the recommended precautions are not followed.

Record your attachment serial number and purchase date in the section reserved below (there is no serial number on the subframe). Your dealer requires this information to give you prompt, efficient service when ordering replacement parts. Use only genuine parts when replacements are required.

If warranty repairs are required please present this registration booklet and original sales invoice to your selling dealer for warranty service.

**This manual should be kept for future reference.
Please check if you have received all the parts for your kit with the list of the bag and the list of the box.**

SERIAL NUMBER : (IF APPLICABLE)	
MODEL NUMBER:	
PURCHASE DATE :	



SAFETY PRECAUTIONS



Careful operation is your best insurance against an accident. Read this section carefully before operating the vehicle and accessory. This accessory is capable of amputating hands and feet and throwing objects. Failure to observe the following safety instructions could result in serious injury. All operators, no matter how experienced they may be, should read this and other manuals related to the vehicle and accessory before operating. It is the owner's legal obligation to instruct all operators in safe operation of the accessory.

GLOSSARY:

In this manual, right and left sides are determined by sitting on the seat of the vehicle facing forward.

In this manual, "accessories" means attachments (snowblower, rotary broom, blade etc.) that you install on the vehicle (lawn tractors, A.T.V. s etc).

TRAINING:



This symbol, "Safety Alert Symbol", is used throughout this manual and on the accessory's safety labels to warn of the possibility of serious injury. Please take special care in reading and understanding the safety precautions before operating the vehicle and accessory.

1. Read this owner's manual carefully. Be thoroughly familiar with the controls and proper use of the vehicle and accessory. Know how to stop the unit and disengage the controls quickly.
2. Never allow children to operate the vehicle nor the accessory. Never allow adults to operate the vehicle nor the accessory without proper instructions.
3. No one should operate the vehicle nor the accessory while intoxicated or while taking medication that impairs the senses or reactions.
4. Keep the area of operation clear of all people, particularly small children and pets.

PREPARATION:

1. Thoroughly inspect the area where the accessory is to be used and remove door mats, all foreign objects and the like.
2. For motorized accessories, disengage all clutches and shift into neutral before starting engine.
3. Do not operate the accessory without wearing adequate winter outer garments. Avoid loose fitting clothing that can get caught in moving parts. Wear footwear that will improve footing on slippery surfaces.

4. Handle fuel with care, it is highly flammable.

- a) Use approved fuel container.
 - b) Never add fuel to a running engine or hot engine.
 - c) Fill fuel tank outdoors with extreme care. Never fill fuel tank indoors.
 - d) Never fill containers inside a vehicle, or on a truck or a trailer bed with a plastic liner. Always place containers on the ground, away from your vehicle, before filling.
 - e) When practical, remove gas-powered equipment from the truck or trailer and refuel it on the ground. If this is not possible, then refuel such equipment on a trailer with a portable container, rather than from a gasoline dispenser nozzle.
 - f) Keep the nozzle in contact with the rim of the fuel tank or container opening at all times, until refueling is complete. Do not use a nozzle lock-open device.
 - g) Replace fuel cap securely and wipe up spilled fuel.
 - h) If fuel is spilled on clothing, change clothing immediately.
5. Never attempt to make any adjustments while the engine (motor) is running (except when specifically recommended by manufacturer).
 6. Let the vehicle and accessory adjust to outdoor temperatures before using.
 7. Never use an accessory without proper guards, plates, or other safety protective devices in place
 8. Always make sure to wear the appropriate safety equipment required (glasses, muffs, mask...) for each type of product. See operation section.
 9. Always make sure of having safe traction on the vehicle by using the recommended accessories (chains, A.T.V. tracks, counterweights...). See operation section.
 10. **Never modify the accessory or any part without the written consent from the manufacturer.**



SAFETY PRECAUTIONS



OPERATION:

1. Do not put hands or feet near, under or inside rotating parts.
2. Exercise extreme caution when operating on or crossing gravel drives, walks or roads. Stay alert for hidden hazards or traffic. Do not carry passengers.
3. After striking a foreign object, stop the engine (motor), disconnect the wire from the spark plug(s) and keep wire away to prevent accidental starting. Thoroughly inspect the accessory for any damage and repair damage before restarting and using the accessory.
4. If the unit should start to vibrate abnormally, stop the engine (motor) and check immediately for the cause. Vibration is generally a warning of trouble.
5. Take all possible precautions when leaving the vehicle unattended. Disengage the power take-off, lower the attachment, place the transmission into neutral, set the parking brake, stop the engine and remove the contact key.
6. Do not run the engine indoors, except when starting the engine and for transporting in or out of the building. Do not operate or let motor run in a storage area without ventilation because gas contains carbon monoxide which is odorless, colorless and can cause death.
7. Never use the accessories across the face of slopes, go from top to bottom. Exercise extreme caution when using equipment on slopes. Do not attempt to clear a steep slope.
8. Never tolerate bystanders in the working zone. Never use an accessory in the direction of bystanders, it might throw gravel or debris that can hurt people or damage property.
9. Never operate the accessory at high transport speeds on slippery surfaces. Use care when backing up.
10. Do not carry passengers.
11. Disengage power to the accessory when it is transported or not in use.
12. Never operate the accessory without good visibility or light.

13. Keep the accessory away from heat sources or flames.

MAINTENANCE AND STORAGE

1. When cleaning, repairing or inspecting the vehicle and accessory, make certain that all moving parts have stopped. Disconnect wire from the spark plug(s) and keep wire away to prevent accidental starting.
2. Check all the bolts and components at frequent intervals to make sure that they are properly tightened.
3. Never store a motorized accessory with fuel in the fuel tank inside a building where ignition sources are present such as hot water and space heaters, clothes dryers, and the like. Allow the engine to cool before storing in any enclosure.
4. Always refer to the owner's manual when you store the accessory and vehicle for a prolonged or an unspecified length of time.
5. Maintain or replace safety and instruction labels, as necessary.
6. For winter accessories, (if applicable), let the engine run for a few minutes after clean snow in order to prevent the rotary parts from freezing.
7. Inspect the vehicle's and accessory's air filter every day. Clean it or replace it as necessary. Change the oil more often when working in dusty conditions. See the vehicle's and accessory's owner's manual.



**THIS SYMBOL MEANS
DANGER !
BECOME ALERT !
YOUR SAFETY IS INVOLVED !**



SAFETY DECALS



REPLACE IF DECALS ARE DAMAGED SEE PARTS BREAKDOWN FOR DECAL LOCATION

DECAL #105126



To avoid serious injury:
Keep hands, feet & clothing away from rotating auger while engine is running.

DECAL #105130

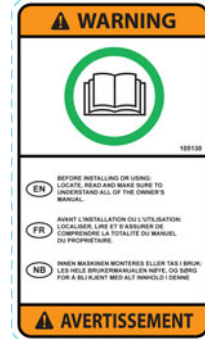

Before installing or using:
Locate, read and make sure to understand all of the owner's manual.

DECAL #105127



To avoid serious injury:
Keep hands out of this discharge chute while engine is running.

DECAL #105131

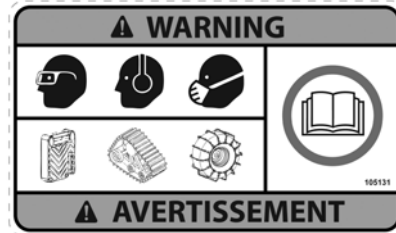

Refer to owner's manual about wearing safety glasses, ear muffs and mask.
Refer to owner's manual for use of counter weights, cat tracks and tire chains.

DECAL #105128



To avoid injury from drive belt:
Keep hands, feet & clothing away.
Do not attempt to install or remove drive belt without reading owner's manual.

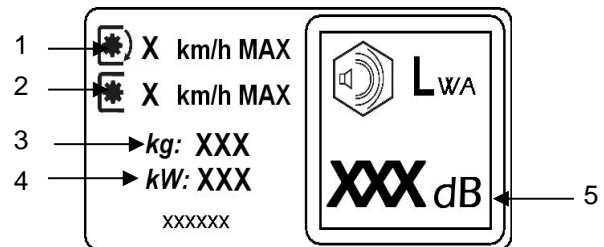

- 1-Do not drive faster than 3 KM/H when the snowblower is in operation.
- 2-Do not drive faster than 10 KM/H when the snowblower is in the raised position.
- 3-The head of the snowblower weighs 98 kg. (without engine).
- 4-The engine wattage is 15 kW. (depends on what engine).
- 5-The sound pressure level (105dBA) is measured at the engine (full charge at 3600 RPM) and depends on the engine that is installed. The value indicated is a reference only.

ASSEMBLY

IMPORTANT: TORQUE ALL BOLTS ACCORDING TO TORQUE SPECIFICATION TABLE (SEE TABLE OF CONTENTS) WHEN STATED: TIGHTEN FIRMLY. REFER TO PARTS BREAKDOWN SECTION FOR PART IDENTIFICATION.

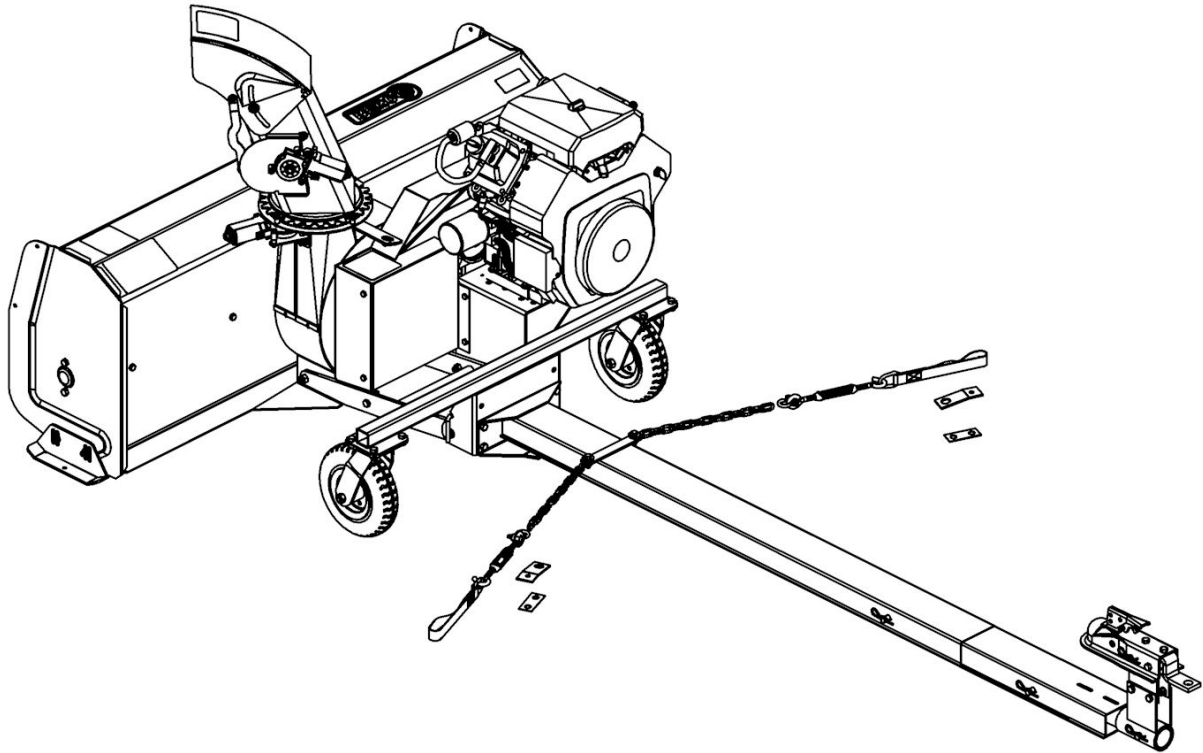

Overall view of snowblower

TOOLS REQUIRED:

- 1 Ratchet
- 3 Sockets 7/16", 1/2", 9/16"
- 3 Wrenches, 7/16", 1/2", 9/16"
- 1 Hexagonal wrench 5/32"
- 1 Wrench (for the nuts on the vehicle's battery posts)

ASSEMBLY

STEP 1

SNOWBLOWER PREPARATION:

Refer to parts breakdown section for parts identification.

Install the chute (item 3).		
Item #	Description	Action
1	Rotation ring	Install over opening (item 2) as shown and align the notches.
3	Chute	Place as shown, turn to lock into place.

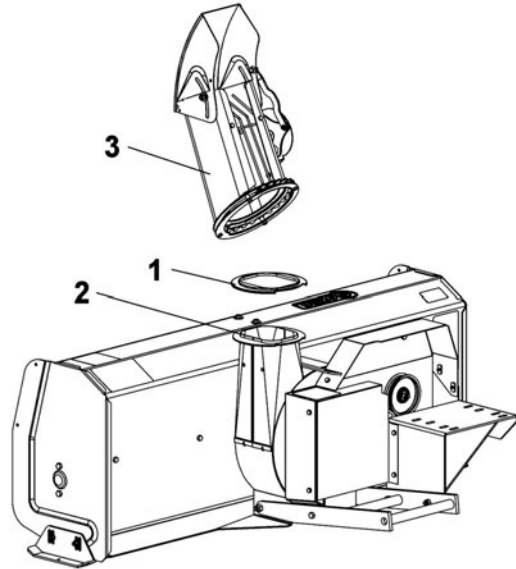

Install chute

Install the motor assembly (item 3).		
Item #	Description	Action
1	Carriage bolts 1/4" n.c. x 1" (qty 2)	Insert inside the chute as shown.
2	Support	Install over the bolts.
3	Motor assembly	Install over the bolts and support.
4	Flange nuts 1/4" (qty 2)	Secure everything in place.

NOTE: Make sure the pin (item 5) on the electric motor is well inserted in the hole on the support.

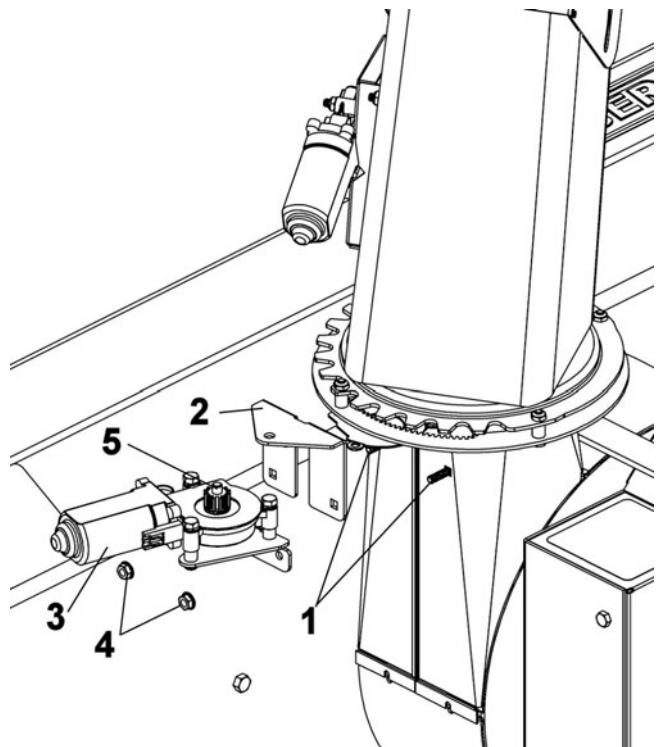

Install the motor assembly

ASSEMBLY

STEP 2 ENGINE INSTALLATION:

IMPORTANT: We recommend using a 15 to 23 hp. engine on this snowblower with a 1" horizontal shaft.

HERE ARE A FEW SUGGESTION OF ENGINES THAT HAVE BEEN TESTED.

Tested engines			
	<i>Honda engines</i>		<i>Kohler engine</i>
HP	18 hp	20 hp	20 hp
Shaft	1"	1"	1"
Model	GX610U QZE6	GX620K QXA6	PA64714
Muffler	VHLM3	VHLM3	KH.24 786 06
Gas tank	Not included	Not included	Not included
Pulley	MB-31 (#104833)	M-31 (#104833)	MB-31 (#104833)

NOTE: The gas tank kit (option #700462 is recommended when it is not included with the engine.

IMPORTANT: THE RIGHT INSTALLATION OF THE ENGINE IS CRUCIAL TO THE GOOD WORKING ORDER OF THE SNOWBLOWER.

NOTE: Figures 1 and 2 show an engine that is not well positioned.

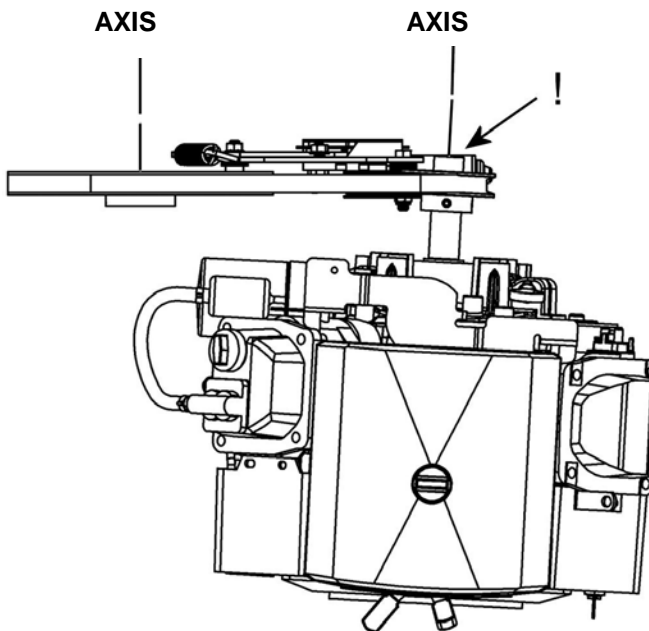

Top view
Figure 1 Engine not in right position

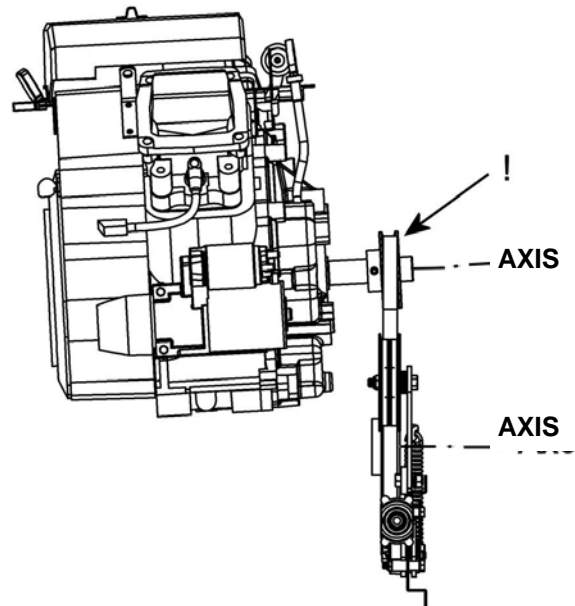

Side view
Figure 2 Engine not in right position

ASSEMBLY

MOTOR INSTALLATION

For engines with an electric starter, it is necessary to connect the vehicle's battery to the starter on the snowblower engine. **You must obtain option #700476 to allow this connection.**

Remove the belt guard (item 1) by removing the three 1/4"x 1/2" hex. bolts (item 2).

Place the engine on the stand (item 3).

Use two 1" shims (item 4) if required, to attain the height of 2 1/8" (reference A) as shown. If more or less height is needed, use a couple of flat washers.

IMPORTANT: Position the center of the engine shaft (item 5) according to these measurements.

1" Engine Shaft: 5 1/8" (reference B) and 2 1/8" (reference A) from the frame of the snowblower.

1 1/8" Engine Shaft: 5 1/2" (reference B) and 2 1/8" (reference A) from the frame of the snowblower.

Choose the set of holes on the stand that correspond with those on the engine and to the position of the engine shaft.

NOTE: Reference B may vary a little bit. Position the engine towards the right as much as possible and just enough so the snowblower disengages properly at all times.

Secure with four hex. bolts 3/8" x 1 3/4" or 3/8" x 2 3/4", flat washers (on the slots, if applicable) and flange nuts.

NOTE: Make sure that the stand for the engine (item 3) is perpendicular to the snowblower frame.

Tighten the bolts firmly.

DANGER:

It is the responsibility of the person who installs the engine and the controls to make sure that the engaging system works well and that the snowblower disengages effectively at all times. It is imperative to make the necessary adjustments if applicable.

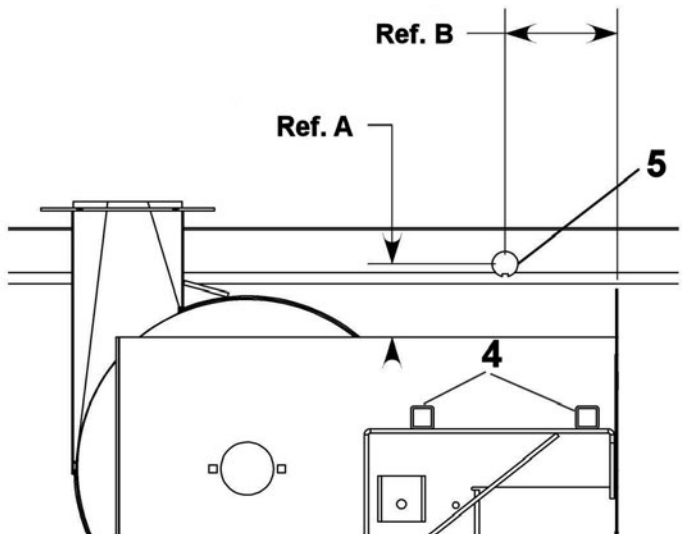
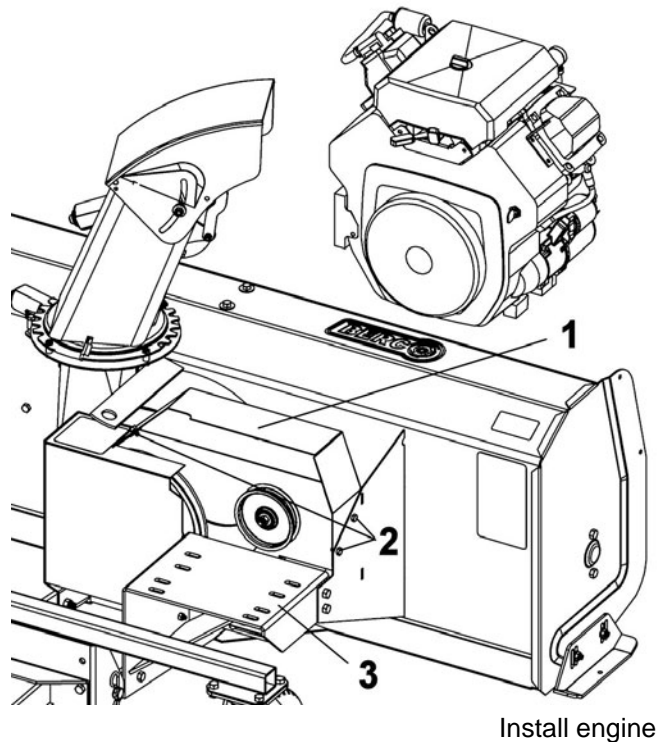

ASSEMBLY

Choose the right pulley (#104833 = 1" or #104839 = 1 1/8") (item 1) according to the diameter of the engine's shaft.

Install the pulley (Fig. 1, item 1) on the engine shaft as shown (hub towards the engine) with a 1/4" x 1/4" x 1 3/4" key.

After positioning the engine, it is very important that the pulleys are aligned and the axis must be parallel as shown in the two views: (fig. 1) top view of the snowblower and (fig. 2) the side view of the snowblower.

(Use some shims if necessary).

Tip: Use a ruler (item 4) on the pulleys

Tighten the set screw firmly.

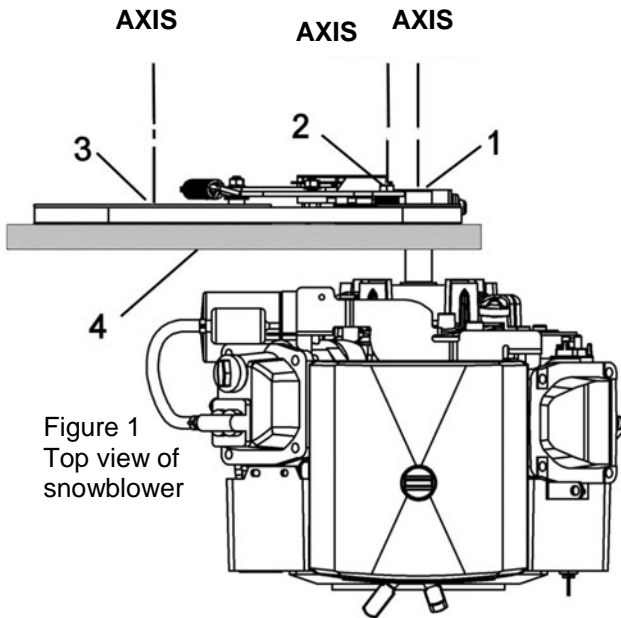

Figure 1
Top view of snowblower

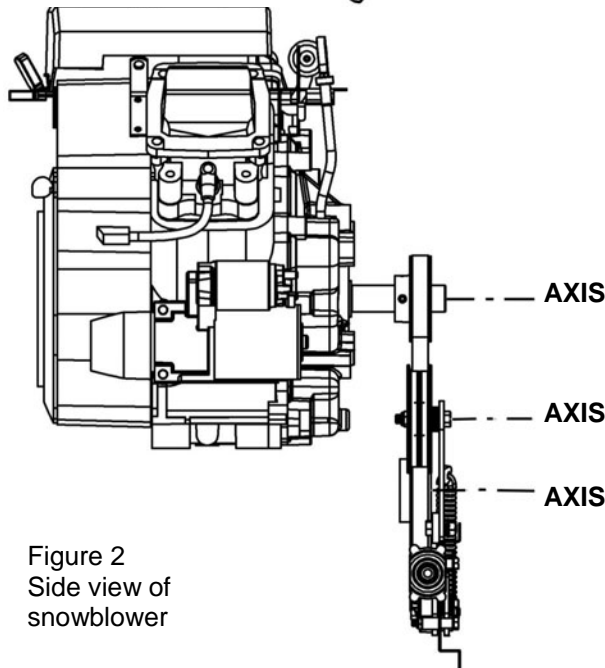
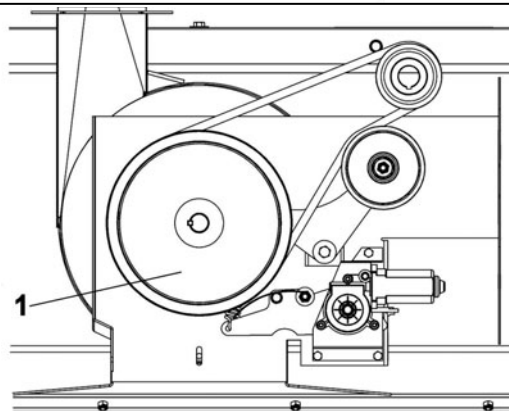

Figure 2
Side view of snowblower

Install the belt on the snowblower pulley (item 1) as shown.

NOTE: The adjustment with the tension on the belt will be done in Step 6.



Install the belt

ASSEMBLY

STEP 3

VEHICLE PREPARATION:

NOTE: A 1 7/8" tow hitch ball is required.

Choose among the three different options to prepare your vehicle (A, B, C).

# Item	Description	Action
A) Install the lift strap (item 1) by looping it around the suspension arm on each side of the vehicle. Tighten the loop firmly.		
B) Install the brackets (item 3) on both sides of vehicle.		
	Bolt and nut from suspension arm	Remove.
2-3	Flat washer and bracket	Install and lightly secure with the original bolt and nut.
C) Install the brackets (item 4) on both sides of vehicle.		
	Nut from suspension arm	Remove.
4	Bracket	Install and lightly secure with the original nut.

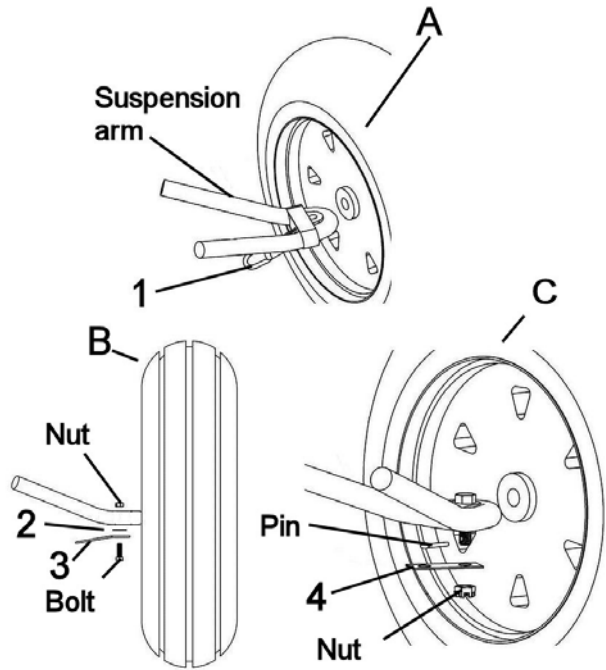

Install the lift strap or the brackets.

STEP 4

SUBFRAME PREPARATION:

NOTE: Determine according to the height of the vehicle which set of holes to use to assemble the wheel support (item 1) to the subframe* (See below).

Install the wheel support (item 1).		
# Item	Description	Action
1	Wheel support	Install to the subframe.
2	Hex bolts 3/8" x 1" (qty 4)	Insert as shown
3	Flange nuts 3/8" (qty 4)	Tighten firmly
*The subframe must be parallel with the ground when the subframe is installed under the vehicle.		

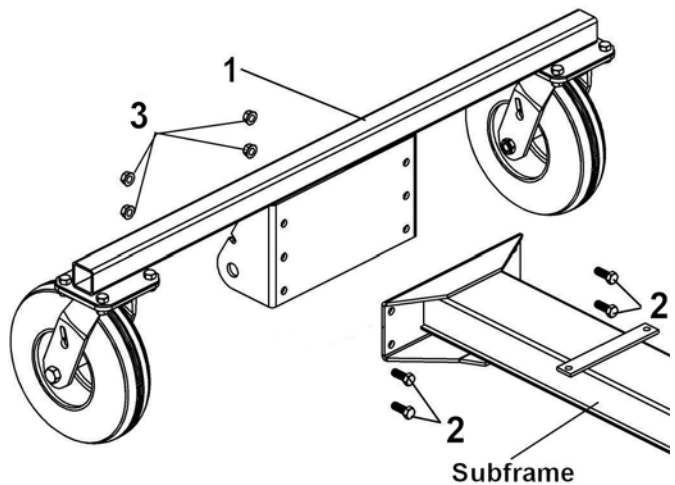

Install the wheel support to the subframe

ASSEMBLY

Install the assembled turnbuckles (item 1).

# Item	Description	Action
1	Assembled turnbuckle (qty 2)	Install on subframe as shown.
2	Flat washer 3/8" (qty 2)	Install on the assembled turnbuckles as shown.
3	Hex bolt 5/16" x 1" (qty 2)	Insert as shown.
4	Nylon insert lock nut 5/16" (qty 2)	Install and tighten loosely enough to allow the parts to move freely.

NOTE: Position the chains as shown and tighten firmly.

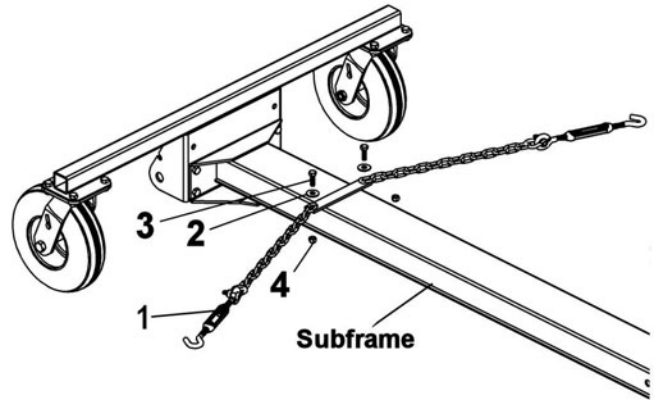

Install the assembled turnbuckles

Install snowblower hitch (item 1).

# Item	Description	Action
1	Snowblower hitch	Install to wheel support.
2	Pin	Slide pin through the holes on wheel support and hitch.
3	Hair pin 4mm	Secure the pin as shown.

NOTE: Make sure the pin is in the locked position.

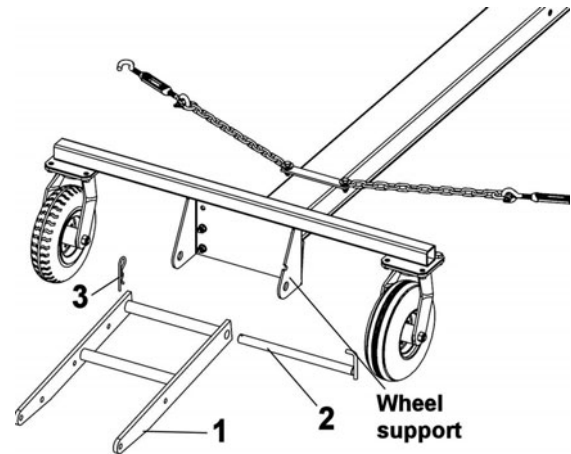

Install snowblower hitch

You have seven different positions on the adjustment tube (item 1) (the adjustment tube can be inverted) to adjust the length of the subframe.

To choose the right adjustment, insert the adjustment tube (item 1) into the subframe (item 2) and insert the rear bracket (item 3) on the adjustment tube. Do not secure.

Drive the vehicle over the subframe, make sure the caster wheels do not touch the front wheels on the vehicle.

Identify the right length and secure in place with the pins (item 4) and 3mm hair pins (item 5).

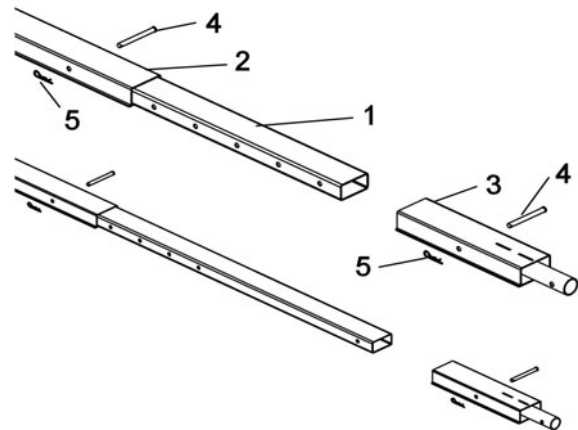

Adjust the length of the subframe

ASSEMBLY

Choose between the three positions (see figure), the height of the hitch support. There must be a maximum of ground clearance according to your vehicle. Position A does not have the hitch support plates (item 1).

Assemble the hitch supports (item 1).		
# Item	Description	Action
1	Hitch support plate (qty 2)	Assemble the hitch support plates on the hitch support.
2	Hex bolt 3/8" x 3/4" (qty 4)	Insert in the chosen holes, (two on each side) and secure with the lock washers 3/8". Tighten firmly.
3	Hitch	Insert on the two hitch supports plates (if applicable).
4	Hex bolt 3/8 x 3" (qty 1)	Insert in the hole as shown and secure with a 3/8" nylon lock nut. Tighten firmly.

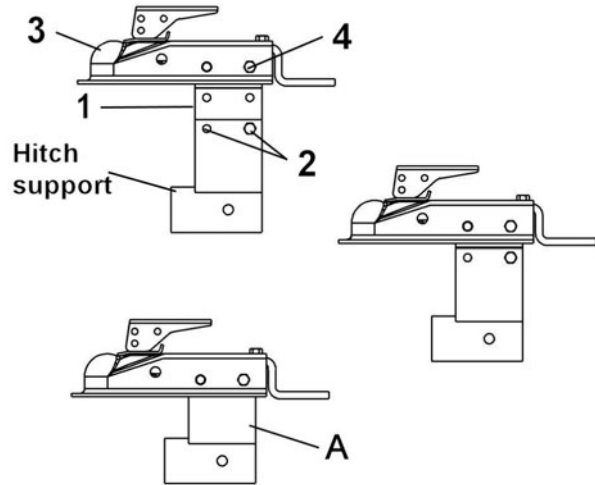

Assemble the hitch support

Install the assembled hitch support (item 1) on the **vehicle's** tow hitch ball.

# Item	Description	Action
1	Assembled hitch support	Insert onto the rear bracket.
2-3	Pin and 3mm hair pin	Secure in place.
4	Assembled hitch support	Attach on the vehicle's tow hitch ball.
5-6	Pin and 3mm hair pin	Secure in place.

Make sure the subframe does not come into contact with vehicle at any time.

NOTE: You can turn the hitch assembly (item 1) by removing the pin (item 2) to facilitate driving the vehicle over the subframe.

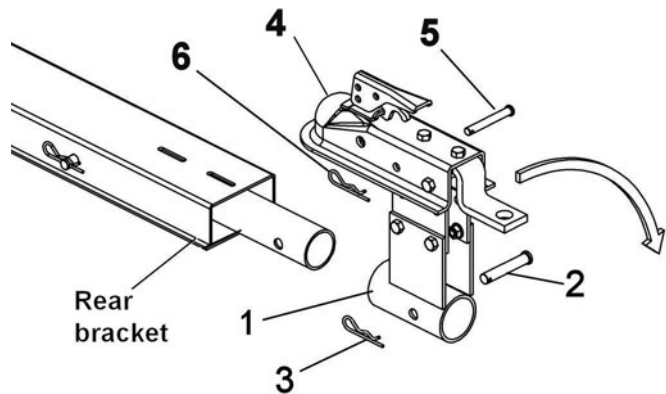

Secure the assembled hitch support on the tow hitch ball

ASSEMBLY

Install the turnbuckles (item 1) into the brackets or into the lift straps.

# Item	Description	Action
1	Turnbuckle (qty 2)	Adjust them so that the subframe is centered under the vehicle .*

*Tighten the turnbuckles firmly in order to tighten the vehicle's suspension.

IMPORTANT: After adjusting the turnbuckles, tighten the nuts on the vehicle's suspension arms firmly. Make sure to lock the nuts with the original locks.

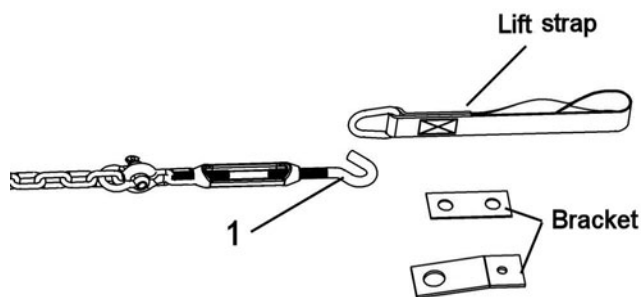

Hook the turnbuckles

IMPORTANT: When the snowblower is raised, the engine must not come into contact with any part of the vehicle.

Insert the winch hook (item 1) into the clevis (item 2) at the end of the chain.

This chain is installed between the winch hook and the flat bar welded on the snowblower (item 4). It acts as a spacer to avoid damage resulting from the snowblower hitting the vehicle when being raised. Retracting the winch completely will indicate that the snowblower has been raised to its appropriate height. There must be no contact between the snowblower engine and the vehicle.

Adjust the chain to the proper length by using the clevis (item 3), leaving enough space between the snowblower and the vehicle.

In order to prevent premature wear to the cable of the winch, the installation of a rubber stopper (item 5) on the cable is recommended (obtained through your dealer).

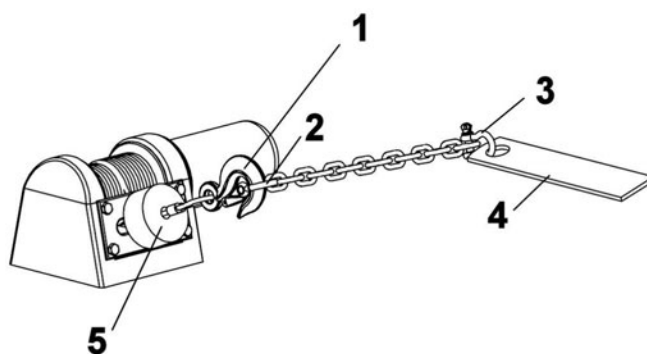

Install chain

ASSEMBLY

STEP 5 CONTROL BOX INSTALLATION:

Choose between the three different ways of securing the control box support (item 1). Use two hex bolts 1/4" x 1/2" or 1 1/2" (items 6 or 2), support brackets (item 4), spacers (item 3) and flange nuts.

Insert the control box (item 5) in the support.

NOTE: The control box must be install horizontally as shown.

Three possible positions

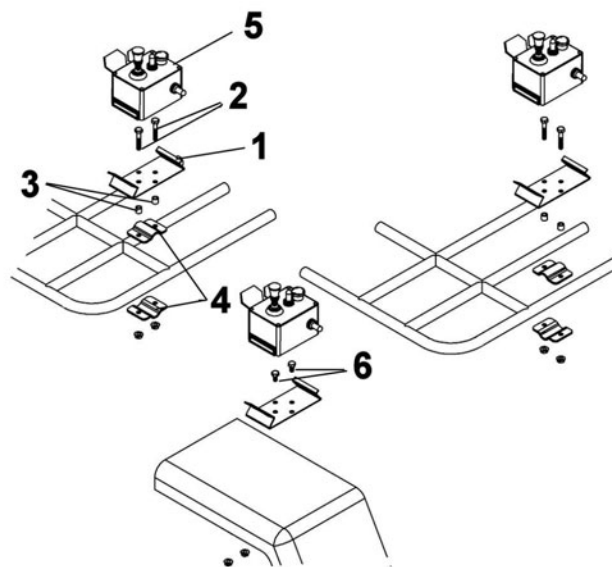

Install the control box

Connect the three connectors at the end of the control box wire to the three corresponding electric motors: short wire on the motor for the chute (A), medium wire on the motor for the deflector (A), long wire on the motor for the belt tensioner (B) and the circuit breaker wire (C).

There will be one black connector that will not be connected. This is to connect the optional snowblower light (D).

Make sure the connectors are well connected together.

NOTE: If the switches don't match the right controls, reconnect the connectors with the right motors.

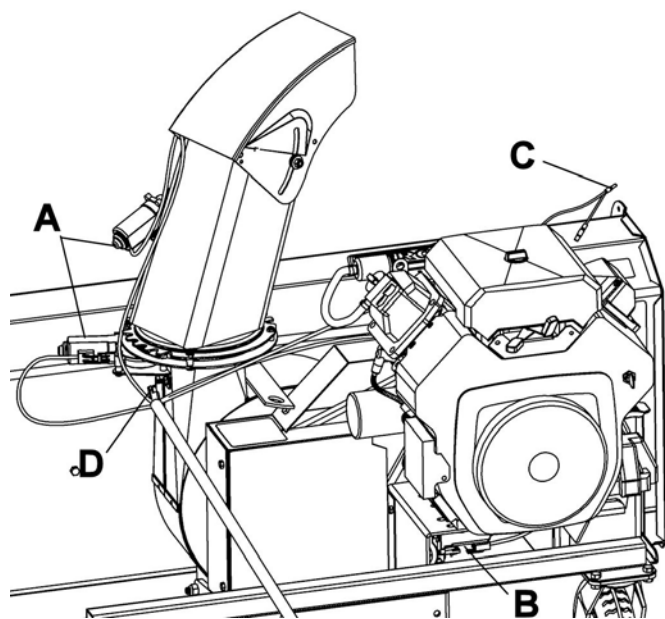

Install the wires to the motors.

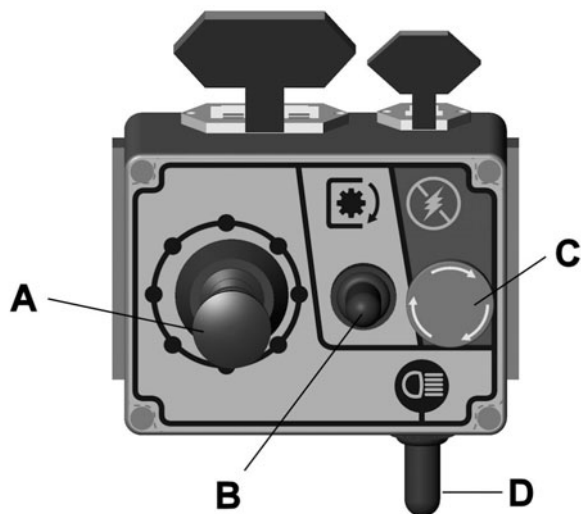

ASSEMBLY

IMPORTANT: The control box is equipped with a red emergency switch. Push down on this button if it becomes necessary to stop the engine quickly.

ENGINE CIRCUIT BREAKER (C) INSTALLATION: (EMERGENCY SWITCH WIRE):

Find the wire (item 1) on the engine that supplies the engine's booster coil and disconnect it.

Assemble the connector (item 2) on the control box wire to the connector (item 3) on the engine wire (item 1).

Assemble the connector (item 5) on control box wire to the connector (item 4) on the engine wire (item 1).

NOTE: The emergency switch must be pulled out to start the engine of the snowblower.

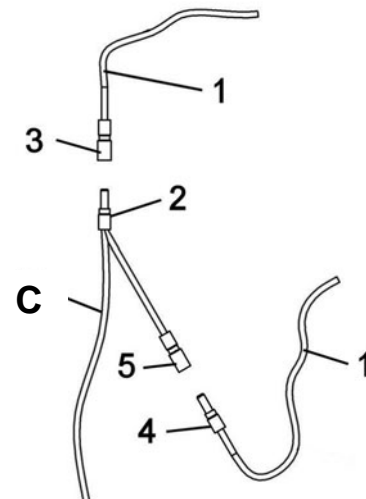
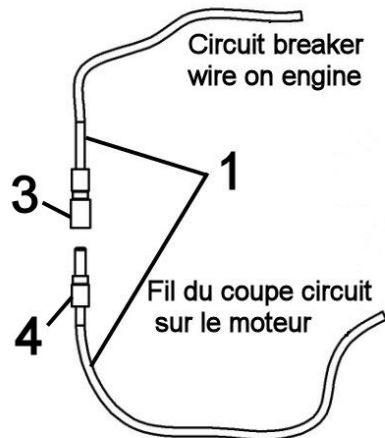

Install engine circuit breaker

Connect the red wire to the vehicle's positive battery post (item 1) and the black wire to the negative battery post (item 2).

Tie the wires to the vehicle with the nylon tie wraps so they do not get in the way.

NOTE: These wires will stay attached to the vehicle.

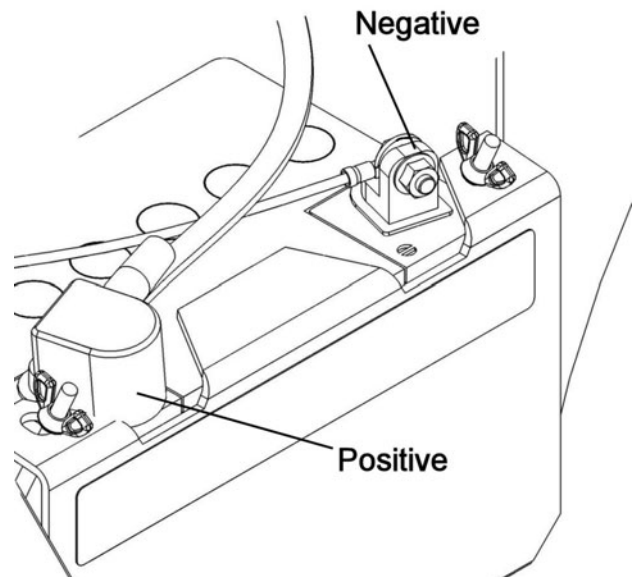

Connect the wires to the battery

ASSEMBLY

IMPORTANT:

Take the time to familiarize yourself with the location of the switches and with their use.

NOTE: If the switches don't match the right controls, reconnect the connectors with the right motors.

Pay particular attention to the switch for the belt tensioner (item 3). This switch must be held in position for a few seconds in order to activate or deactivate the lever of the belt tensioner.

Make sure that the action is complete when you engage or disengage the snowblower.

DANGER:

It is the responsibility of the person who installs the engine and the controls to make sure that the engaging system works well and that the snowblower disengages effectively at all times. It is imperative to make the necessary adjustments if applicable.

Identification of the switches:

1. Emergency kill switch. (Pull out to start).
2. Joystick to move the chute and the deflector.
3. Switch for the belt tensioner to engage or disengage the snowblower.
4. Switch for optional light kit.

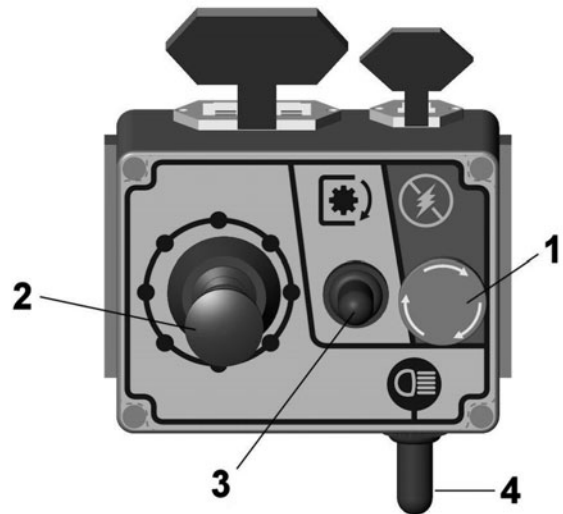
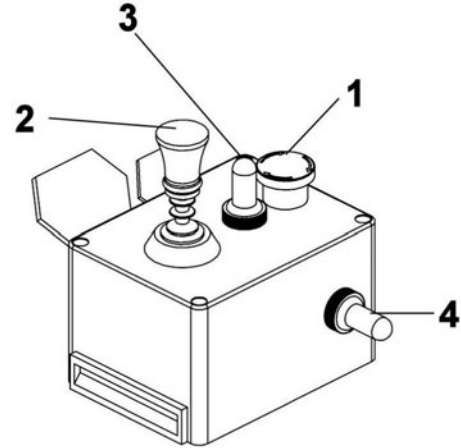

Identify the controls.

Turn the chute to its maximum towards the right.

Secure the wire of the motor for the deflector with a couple of tie wraps (item 1 & 2) as shown.

Secure the other wires with a few tie wraps (items 3, 4 & 5) as shown.

Be sure to leave enough wire length to be able to turn the chute freely.

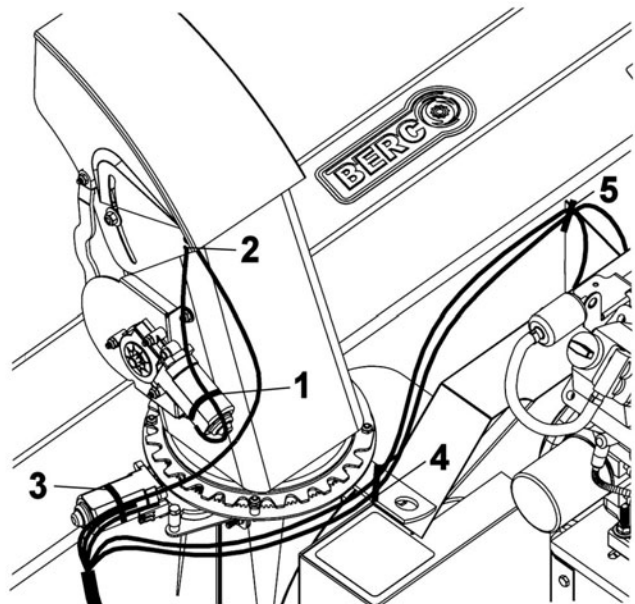

Secure wires as shown

ASSEMBLY

STEP 6 FINAL ADJUSTMENTS



DANGER



Never let the snowblower motor run without the belt guard in place.



WARNING



TO PREVENT INJURIES:
Start the engine, engage and disengage the clutch to be sure it functions normally. Make sure the emergency switch is working perfectly. Make sure all the controls are working well.

Adjust the idler pulley (item 2) as follows:

After installing the belt, you may run the engine without the belt guard, but only for the time needed to verify the belt alignment.

Do not leave the snowblower without supervision.

Neither you or anyone must approach the moving parts.

Observe and familiarize yourself with the action time required to engage and disengage the snowblower. Then make sure that the belt is well aligned, especially on the idler pulley.

If necessary, you can add or remove a flat washer for final adjustment on the idler pulley (item 2).

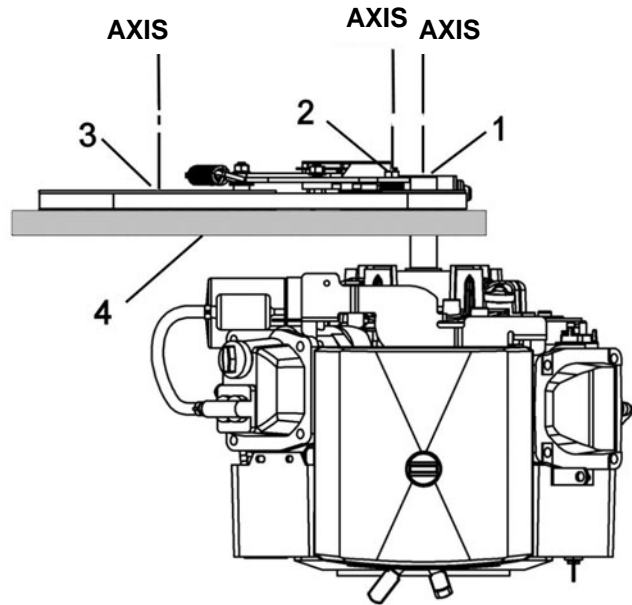
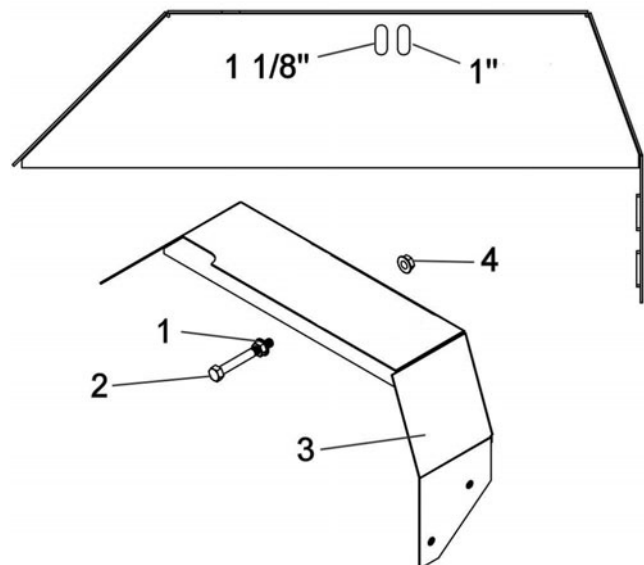

Figure 1
Top view of snowblower. All the pulleys are aligned and the engine is well installed.

Make sure the belt guide (item 2) is installed in the appropriate hole on the belt guard (item 3) according to the diameter of the engine shaft used. The hole on the right hand is for the 1" shaft and the hole on left hand is for the 1 1/8" shaft (sitting on the vehicle).

Insert a flange nut 5/16" (item 1) on the hex bolt 5/16" x 2 3/4" (item 2) as shown. Install the assembled bolt in the belt guard and secure with the other flange nut 5/16" (item 4).

IMPORTANT: make sure the belt does not rub on the belt guide when the belt is engaged.



Install belt guide

ASSEMBLY

DANGER:

It is the responsibility of the person who installs the engine and the controls to make sure that the engaging system works well and that the snowblower disengages effectively at all times. It is imperative to make the necessary adjustments if applicable.

If necessary: Move the engine in the slots to reduce the tension on the belt when disengaged.

Install the belt guard (item 1) and secure in place with three hex bolts 1/4" x 1/2" (item 2).

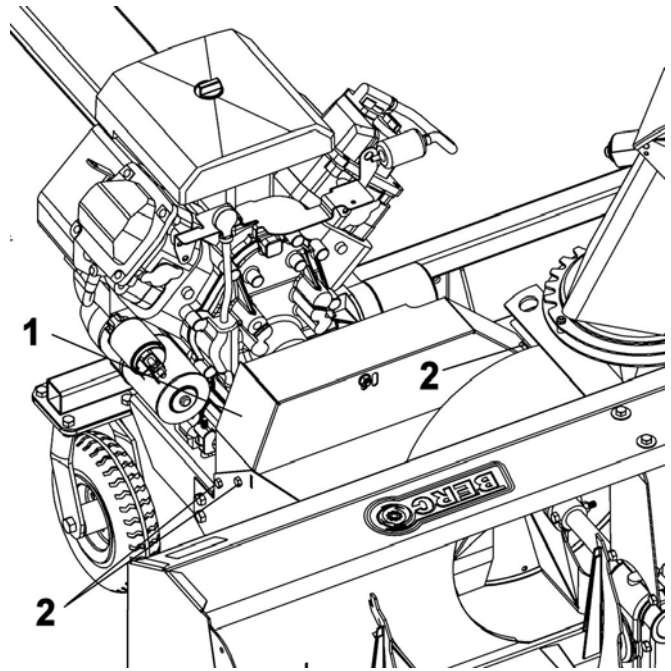

Install belt guard

VERIFY SKID SHOE ADJUSTMENT:

LEVEL PAVED SURFACE: Adjust skid shoes to allow 3/16" to 1/4" clearance (A) between cutting edge and surface.

UNEVEN OR GRAVEL SURFACE: Adjust skid shoes to allow 1/2" to 5/8" clearance (A) between cutting edge and surface.

VERIFY TIRE PRESSURE:

Check and adjust the pressure of the tires on the sub-frame at: 50 psi
Tire pressure must be even on both sides.

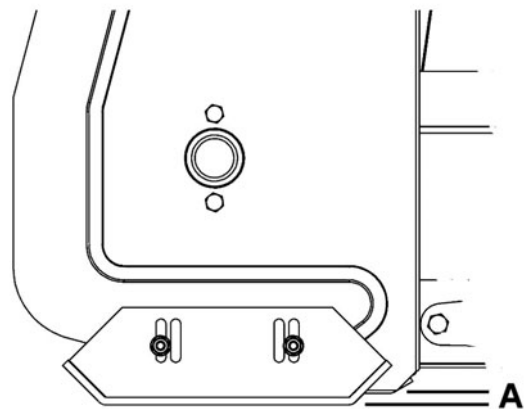

Adjust skid shoes

OPERATION



WARNING



Read the vehicle's owner's manual carefully. Be thoroughly familiar with the controls & proper use of the attachment. Know how to stop the unit & disengage the controls quickly.



WARNING



- Do not attempt to clear plugged chute, auger or fan of snow while the snowblower's engine is running.
- Disengage snowblower.
- Lower snowblower onto ground.
- Set the parking brake.
- Stop engine, remove the ignition key, disconnect the wire from spark plug(s) and keep away from spark plug(s) to prevent accidental starting.
- Make sure all moving parts have stopped.
- Do not use hand to unplug chute.
- Use a 36" (924 mm.) minimum length stick or board.



WARNING



TO PREVENT INJURIES AND FOR MORE TRACTION WHEN USING SNOWBLOWER:

- Do not drive faster than 3 km/hr (2 m/hr) with snowblower on the ground.
- Do not drive faster than 10 km/hr (6 m/hr) with the snowblower in raised position.
- Do not operate on a slope greater than 10°.
- Vehicle manufacturer approved tire chains are required.

OPERATING THE SNOWBLOWER

- a) Make sure the snowblower is clear of snow before engaging the clutch.
- b) Make sure that the auger and impeller operate freely.
- c) Start the snowblower engine.
- d) Before engaging the snowblower drive, always have the engine running at max R.P.M.
- e) Operate the snowblower at maximum engine R.P.M.

IMPORTANT: USE FULL ENGINE R.P.M. WHEN REMOVING WET, STICKY SNOW. LOW R.P.M. POWER WILL TEND TO PLUG THE CHUTE.

ELECTRICAL CONTROLS

See installation of the control box in order to identify the controls.

RAISING AND LOWERING THE SNOWBLOWER:

Use the winch switch control to raise and lower the snowblower.

IMPORTANT: There is no lift stopper. Make sure there is no interference between the snowblower engine and the vehicle when lifting the snowblower.

EMERGENCY SWITCH:

Push down on the emergency button to stop the engine.

IMPORTANT: The emergency button has to be pulled out in order to start the snowblower engine.

REMOVING SNOW

When removing snow, do not use the snowblower as a dozer blade to push snow. Allow snowblower to ingest snow at its own speed. If the speed of your A.T.V. is too fast, the snowblower may become overloaded and plug. .

CLEARING A CLOGGED DISCHARGE CHUTE:

Hand contact with the rotating impeller inside the discharge chute is the most common cause of injury associated with snowblowers. Never use your hand to clean out the discharge chute.

To clear the chute:

1. Lower snowblower to the ground and set parking brake.
2. SHUT THE ENGINE OFF & REMOVE KEY!
3. Wait 10 seconds to be sure the **all moving parts** such as the impeller blades have stopped moving.
4. Disconnect wire from the spark plug(s) and keep wire away to prevent accidental starting.
5. Always use a clean-out tool of at least 36" in length, NEVER YOUR HANDS.

MAINTENANCE



WARNING



TO PREVENT INJURIES:

- Stop the snowblower motor.
- Apply parking brakes.
- Remove the ignition key.
- Disconnect the wire from the spark plug(s) and keep away from spark plug(s) to prevent accidental starting.

MAINTENANCE

- Check mounting bolts at frequent intervals for proper tightness in order to prevent costly repairs. Make sure your snowblower is in safe working condition.
- Provide adequate blocking before working under the snowblower when in raised position.

ADJUSTMENTS

SKID SHOE ADJUSTMENT:

Level Paved Surface: Adjust skid shoes to allow 3/16" to 1/4" clearance between cutting edge and surface.

Uneven or Gravel Surface: Adjust skid shoes to allow 1/2" to 5/8" clearance between cutting edge and surface.

CUTTING EDGE MAINTENANCE

Verify from time to time the wearing on the cutting edge to make sure you do not wear out the base of the snowblower's chassis. This cutting edge is reversible. Unscrew the bolts and turn the cutting edge, reinstall and tighten the bolts securely.

SNOWBLOWER PULLEY REPLACEMENT or ALIGNMENT:

Clean the parts before aligning or replacing the pulley. Apply some "Lock Tite" 2760 on the key and the set screws. Tighten firmly.

LUBRICATION

Grease the wheel axles, the fork pivots after every sixteen hours of use.

Apply oil at all pivot points.

Chute Rotation System: Oil chute base, rotation worm every sixteen hours of operation.

Gear box:

Check the oil annually. If necessary, add AGMA 5 EP or SAE 90 oil.

The gear box should have a total of 155 ml of oil or filled to the rim of the bolt hole when installed on the snowblower. (see figure)

To avoid damage to the snowblower:

Use only the original shear bolts (grooved bolts).

#104000 in bags of 10 for the augers.

#103999 in bags of 10 for the fan.

The use of any other shear bolt will not insure any protection and may void the warranty.

IMPORTANT: It is very important to replace the augers in the same position as shown in the drawing before installing the shear bolts.

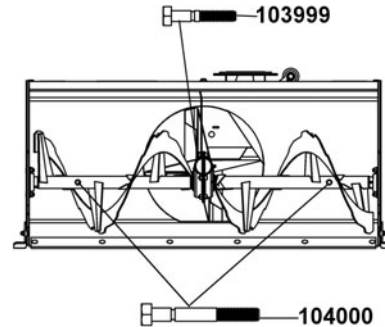

AUGER AND FAN SHEAR BOLT REPLACEMENT

The shear bolts are to be considered a preventive measure and not an assured protection. Operator vigilance is required. Thoroughly inspect the areas where the snowblower is to be used and remove all foreign objects.

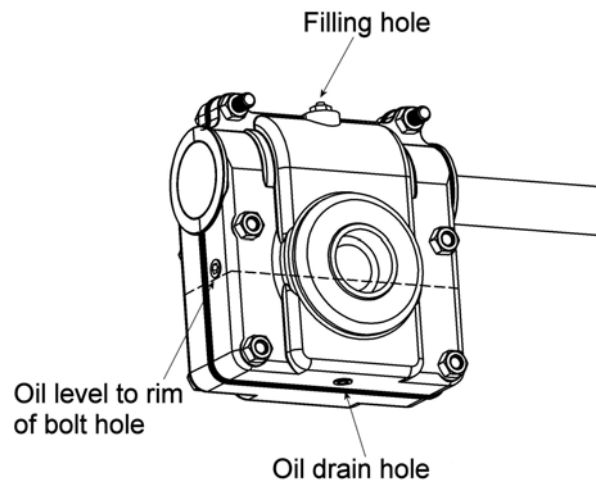

Gear Box

BELT REPLACEMENT



CAUTION



Never use the snowblower without the belt guard.

BELT REPLACEMENT:

For belt part number, refer to parts breakdown section for parts identification.

- a) Remove the belt guard (item 1) by removing the three hex bolts 1/4" x 1/2" (item 2).
- b) Remove the tension from the belt by pushing on the switch for the belt tensionner.
- c) Remove the old belt from the engine pulley (item 3).
- d) Activate the switch for the electric motor for the belt tensionner to release the brake (item 4).

NOTE: This step is necessary to free the belt from the snowblower pulley.

- e) After installing the belt, you may run the engine without the belt guard but only to verify the belt alignment. Do not leave the snowblower without supervision. Neither you or anyone else must approach the moving parts. Engage and disengage the snowblower to verify if the belt is well aligned, especially on the idler pulley (item 5).

Make sure to hold the switch long enough so that the pulley sits well on the belts.

If necessary, you can add or remove a flat washer on the idler pulley for final adjustments.

- f) Reinstall the belt guard.

IMPORTANT: make sure the belt does not rub on the belt guide (item 6) when the belt is engaged.

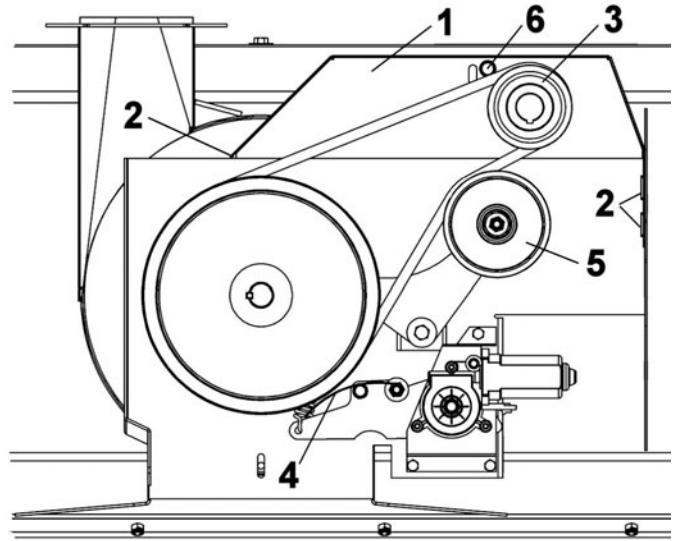

Belt replacement

REPLACEMENT OF ONE OR TWO SECTIONS OF THE AUGER AND / OR GEAR BOX

For belt part numbers, refer to snowblower parts breakdown section for parts identification

Snowblower must be detached & disconnected from the vehicle to replace the auger or the gear box.

- a) Remove the gas tank from the support (place on the ground to avoid any spills)
- b) Remove the belt guard.
- c) Remove the belt. See manual.
- d) Turn the snowblower face down (optional).
- e) Loosen the 2 set screws (item 1) on the pulley (it may be necessary to heat the set screw and center of pulley to soften the "loctite").
- f) Remove the pulley.
- g) Loosen the 2 set screws (item 2) on the bearing behind the snowblower (it may be necessary to heat the set screw to soften the "loctite").
- h) Remove all the bolts (item 3) and the nuts that support the gear box and its support.
- i) Remove the assembly (gear box, its support, the fan and augers) from the snowblower and save the nylon bushings and bearings.
- j) Replace the appropriate parts. Insert the shaft and the key into the new gear box (if required).
- k) Install the new auger or augers on their respective side in the position shown with the same nylon bushings on the shaft of the new gear box as shown.
- l) Re-install parts by repeating steps backwards.

IMPORTANT: You must clean the parts and apply some "Loctite" 2760 on the key of the pulley and the set screws of the bearing and pulley. Tighten firmly.

Follow the instructions in the belt replacement and adjustments sections.

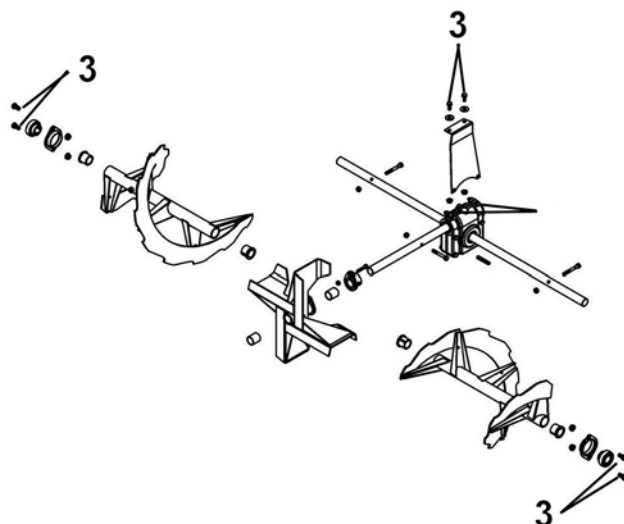
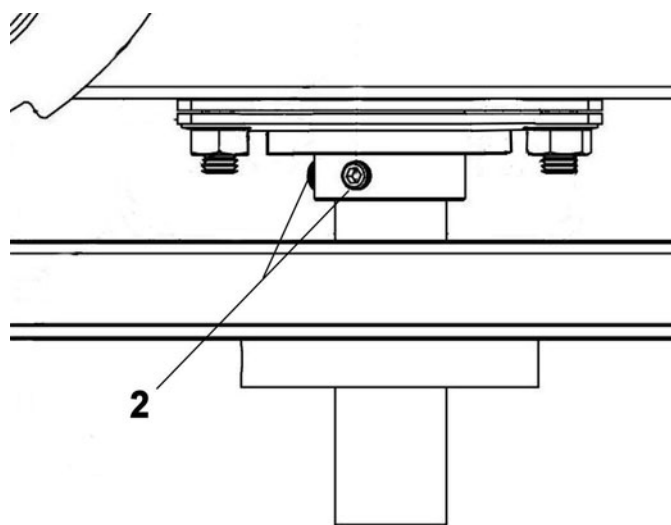
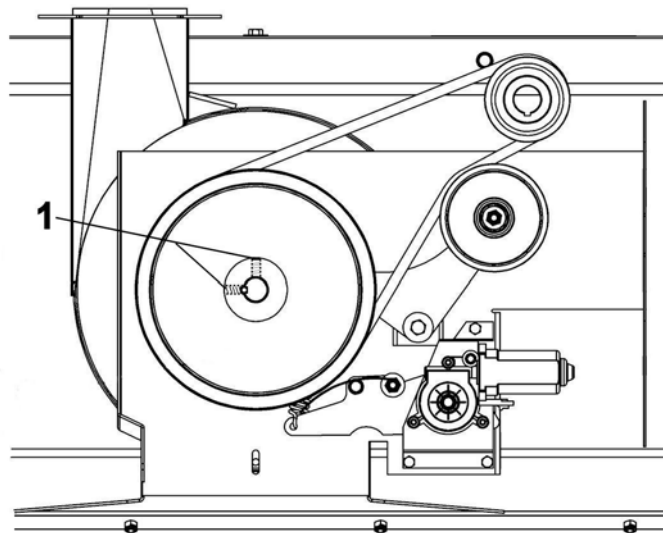

DISMOUNTING & STORAGE

DISMOUNTING

- a. Select a level surface, set parking brake, stop the engine, and remove the ignition key to prevent accidental starting.
- b. Lower the accessory to the ground
- c. Unhook the turnbuckles from the front of the vehicle, (Tip: slacken one of the turnbuckles in order to keep the adjustment), the hook from the winch and the hitch from the rear of the vehicle.
- d. Remove the control box (item 1) from the support (item 2). Disconnect the wires (item 3) and place the box on the accessory.
- e. Remove the vehicle.

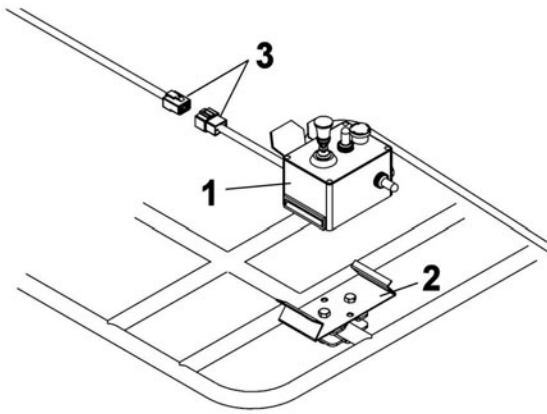

STORAGE

- a) Clean snowblower and subframe thoroughly and repaint all parts from which paint has worn.
- b) List the replacement parts that will be needed to be replaced before the next season.
- c) Follow the instructions in the Lubrication section.
- d) Concerning the snowblower engine, follow the instructions in the engine owner's manual.
- e) Store the snowblower and the subframe in a dry place.

TROUBLESHOOTING

(For identification, see the parts breakdown)

PROBLEM	POSSIBLE CAUSES	CORRECTIVE ACTION
Snowblower vibrates or is abnormally noisy.	Damaged pulley.	Replace pulley.
	Damaged bearing.	Replace bearing.
	Damaged fan or sections of auger.	Dismount & repair or replace fan.
Auger stopped turning.	Shear bolt broken.	Replace shear bolt. Also see "Maintenance" section.
	Chain broken or connecting link unlocked.	Remove chain guard. Inspect and repair if needed.
Snowblower stopped turning.	The belts are damaged or snapped.	Check & replace damaged belts.
Belt is worn at a specific point.	Snowblower was engaged when already plugged.	Make sure auger & fan are not plugged or frozen before engaging snowblower.
	Lack of tension on the belt.	Replace the tension spring if it has lost its efficiency.
Belt showing premature wear.	Spring stretched.	Check spring. Replace if stretched.
	Engine and pulleys are misaligned	Realign the engine and pulleys.
Chute rotation is difficult.	Dirt or ice may be underneath chute.	Clean the base of chute & the rotation ring. Lubricate chute inside & out and the rotation worm.
The chute plugs easily.	Snowblower engine is turning too slowly.	Always have engine at full R.P.M. when using the snowblower.
	Advancing too quickly with vehicle.	Reduce speed. Allow snowblower to ingest snow at its own speed.
Snowblower digs into ground.	Ground is not frozen or too soft.	Adjust skid shoes lower so they may better support the snowblower.
Snowblower does not raise evenly.	Tire pressure uneven from one side to another.	Verify and adjust tire pressure: 50 p.s.i.
The engine does not start	The emergency button is pushed down.	The emergency button must be pulled up to start the engine of the snowblower.
	Other reasons	See the engine's owner's manual.
Electric motor does not work	Motor overheating.	These motors are equipped with an internal protector. Wait 10 minutes before using.

PARTS BREAKDOWN ROTATION SYSTEM WITH CHUTE

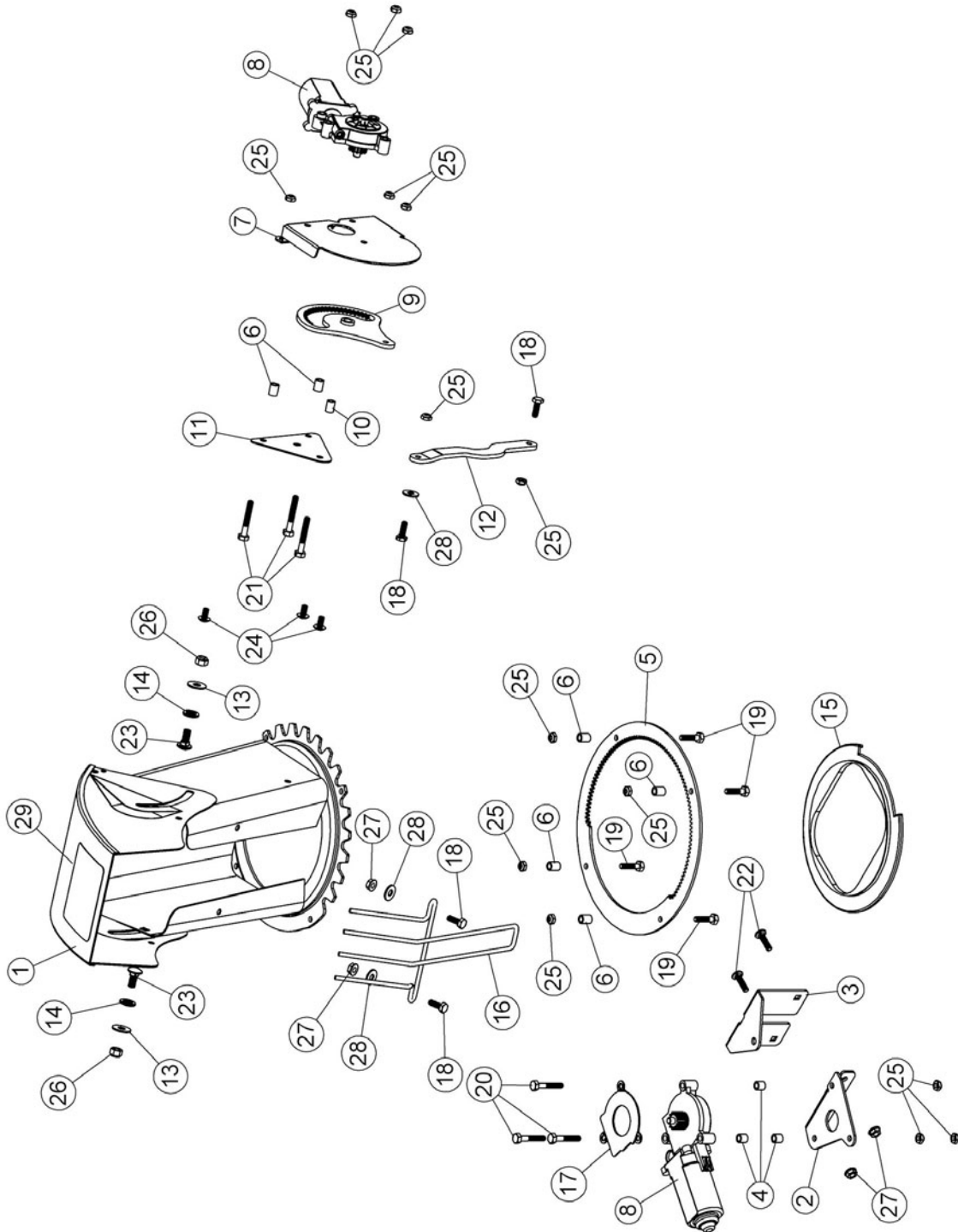

PARTS LIST ROTATION SYSTEM WITH CHUTE

Ref. Réf.	English description	Description française	Qty. Qté.	Part # Pièce #
1	Chute	Goulotte	1	103936
2	Bracket	Support	1	103971
3	Reinforcement plate	Plaque de renforcement	1	103972
4	Spacer	Espaceur	3	103368
5	Rotation ring	Anneau de rotation	1	103974
6	Spacer	Espaceur	6	103361
7	Bracket	Support	1	103375
8	Electric motor	Moteur électrique	2	103378
9	Lever	Levier	1	103365
10	Oil lite bushing	Coussinet imprégné d'huile	1	103362
11	Plate	Plaque	1	103363
12	Arm	Bras	1	103364
13	Nylon flat washer 11/32"	Rondelle plate de nylon 11/32"	2	102009
14	Nylon flat washer 7/16"	Rondelle plate de nylon 7/16"	2	102011
15	Rotation ring	Anneau de rotation	1	103943
16	Hand guard	Fourche protectrice	1	102012
17	Protective plate	Plaque protectrice	1	105404
18	Hex. bolt 1/4" n.c. x 3/4"	Boulon hex. 1/4" n.c. x 3/4"	4	O/L
19	Hex. bolt 1/4" n.c. x 1"	Boulon hex. 1/4" n.c. x 1"	4	O/L
20	Hex. bolt 1/4" n.c. x 1 1/2"	Boulon hex. 1/4" n.c. x 1 1/2"	3	O/L
21	Hex. bolt 1/4" n.c. x 1 3/4"	Boulon hex. 1/4" n.c. x 1 3/4"	3	O/L
22	Carriage bolt 1/4" n.c. x 1"	Boulon à carrosserie 1/4" n.c. x 1"	2	O/L
23	Carriage bolt 5/16" n.c. x 3/4"	Boulon à carrosserie 5/16" n.c. x 3/4"	2	O/L
24	Machine screw T.H. 1/4" n.c. x 1/2"	Vis mécanique T.H. 1/4" n.c. x 1/2"	3	O/L
25	Nylon insert lock nut 1/4" n.c. (thin)	Écrou à garniture de nylon 1/4" n.c.(mince)	15	O/L
26	Nylon insert lock nut 5/16" n.c.	Écrou à garniture de nylon 5/16" n.c.	2	O/L
27	Flange nut 1/4" n.c.	Écrou à bride 1/4" n.c.	4	O/L
28	Flat washer 5/16" hole	Rondelle plate 5/16" trou	3	O/L
29	Danger decal chute	Décalque danger goulotte	1	105127

O/L = Obtain Locally

PARTS BREAKDOWN SUBFRAME

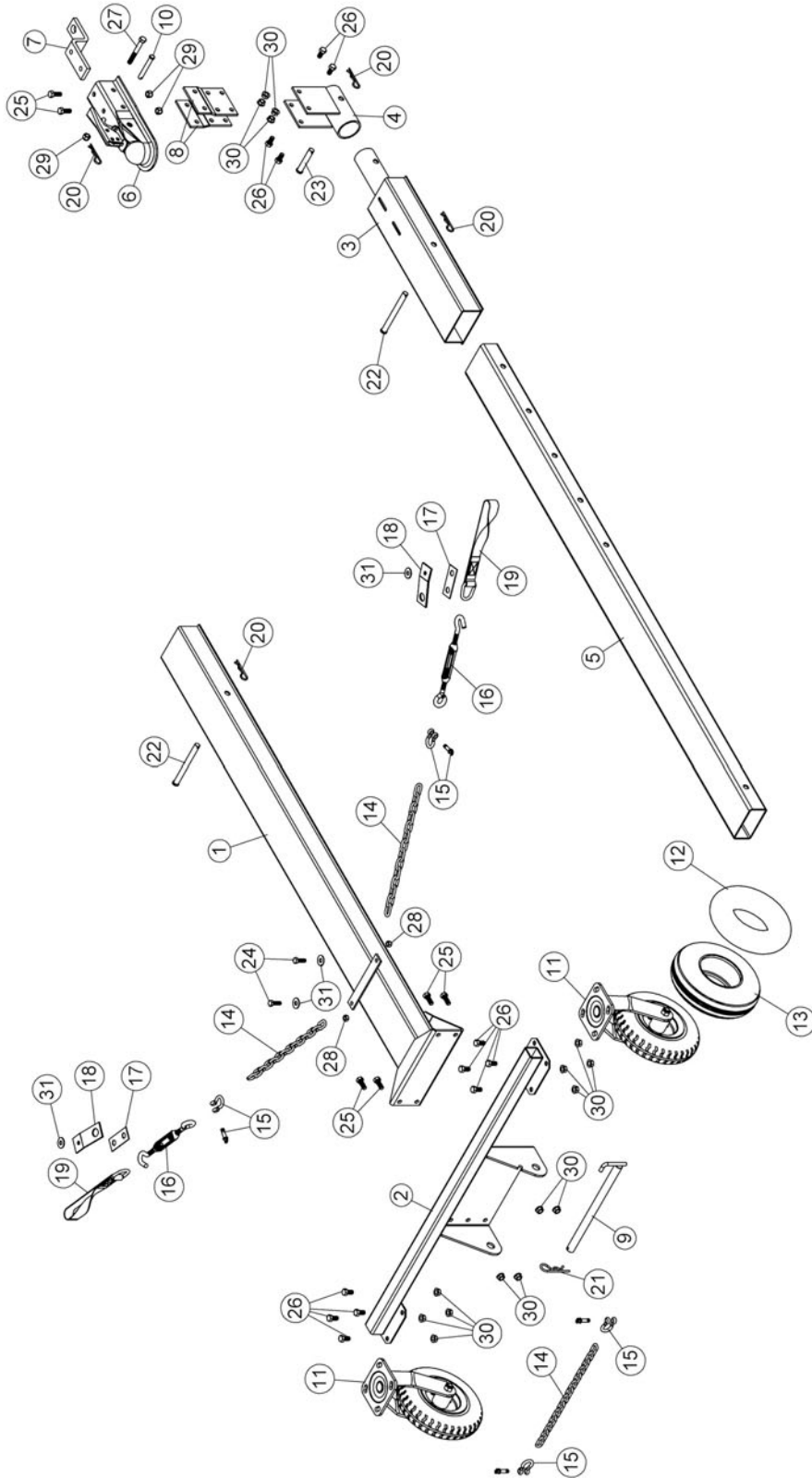

PARTS LIST SUBFRAME

Ref. Réf.	English description	Description française	Qty. Qté.	Part # Pièce #
1	Subframe	Sous-châssis	1	104957
2	Wheel support	Support de roue	1	104770
3	Rear bracket	Fixation arrière	1	104956
4	Hitch support	Support d'attache	1	104958
5	Adjustment tube	Tube d'ajustement	1	104959
6	Hitch	Attache	1	104639
7	Hitch ball support	Support de boule d'attelage	1	104640
8	Hitch support plate	Plaque de support d'attache	2	104641
9	Pin	Goupille	1	104759
10	Pin	Goupille	1	104642
11	Caster wheel assembly	Roue pivotante assemblée	2	104779
12	Inner tube 250-4	Chambre à air 250-4	1	102675
13	Tire 280/250-4	Pneu 280/250-4	1	102674
14	Chain	Chaîne	3	104633
15	Shackle Ptd Z	Clevis Pqé Z	4	102343
16	Turnbuckle	Tendeur	2	104634
17	Bracket	Fixation	2	104632
18	Bracket	Fixation	2	105194
19	Lift strap	Sangle de relevage	2	103613
20	Hair pin 3mm	Goupille à ressort 3mm	4	102617
21	Hair pin 4mm	Goupille à ressort 4mm	1	102054
22	Pin	Goupille	2	104961
23	Pin	Goupille	1	104999
24	Hex. bolt 5/16" n.c. x 1"	Boulon hex. 5/16" n.c. x 1"	2	O/L
25	Hex. bolt 3/8" n.c. x 1"	Boulon hex. 3/8" n.c. x 1"	6	O/L
26	Hex. bolt 3/8" n.c. x 3/4"	Boulon hex. 3/8" n.c. x 3/4"	12	O/L
27	Hex. bolt 3/8" n.c. x 3"	Boulon hex. 3/8" n.c. x 3"	1	O/L
28	Nylon insert lock nut 5/16" n.c.	Écrou à garniture de nylon 5/16" n.c.	2	O/L
29	Nylon insert lock nut 3/8" n.c.	Écrou à garniture de nylon 3/8" n.c.	3	O/L
30	Flange nut 3/8" n.c.	Écrou à bride 3/8" n.c.	16	O/L
31	Flat washer 3/8" hole	Rondelle plate 3/8" trou	4	O/L

O/L = Obtain Locally

PARTS BREAKDOWN SNOWBLOWER

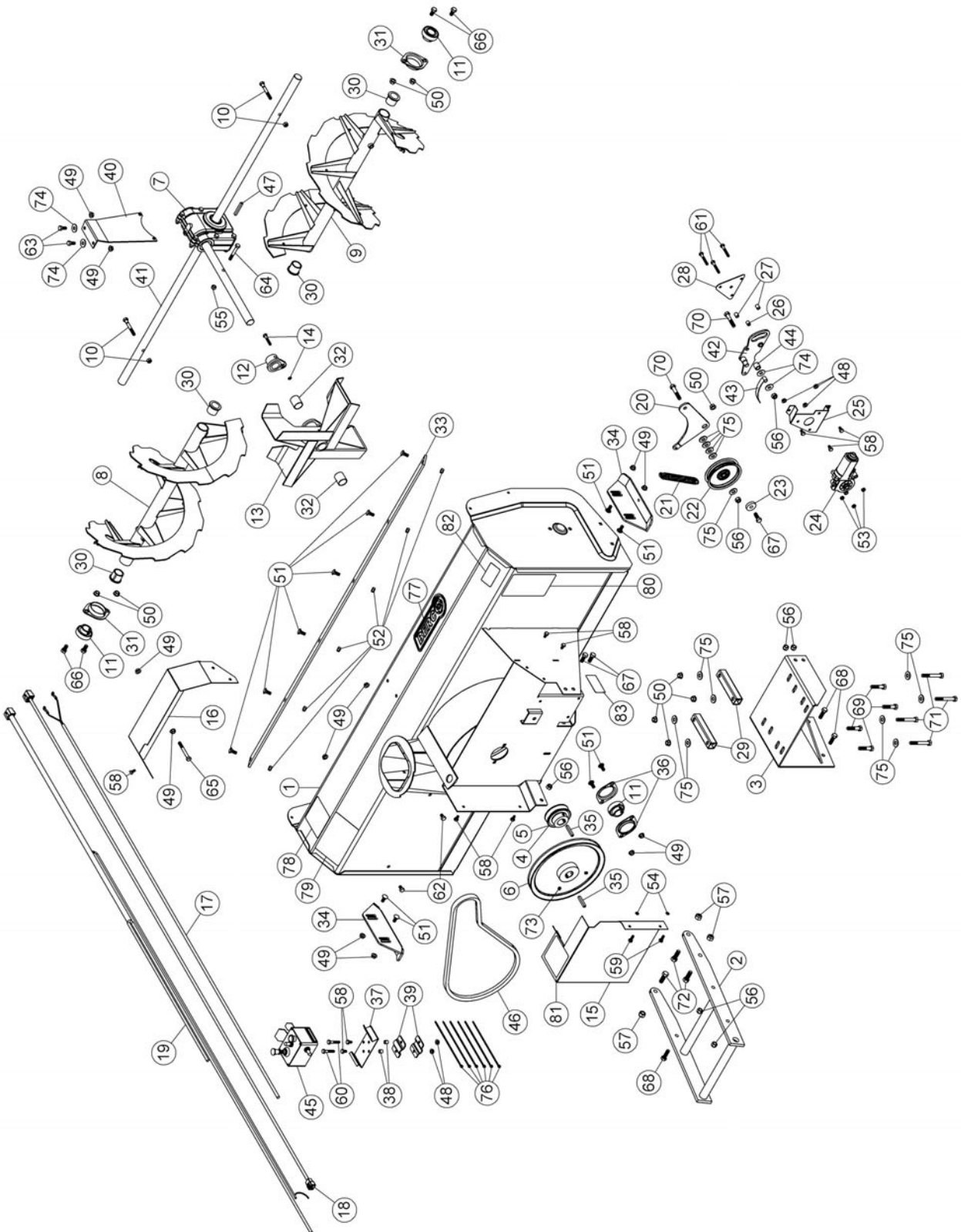

PARTS LIST SNOWBLOWER

Ref. Réf.	English description	Description française	Qty. Qté.	Part # Pièce #
1	Frame 54"	Châssis 54"	1	104780
2	Hitch	Attache	1	104781
3	Engine support	Support-moteur	1	104782
4	Pulley 3.15" with set screw	Poulie 3.15" avec vis pression	1	104833
5	Pulley 3.55" with set screw	Poulie 3.55" avec vis pression	1	104839
6	V pulley	Poulie en V	1	104774
7	Gear box left rotation	Boîte d'engrenage rotation gauche	1	104718
8	Auger 54" left	Vis 54" gauche	1	104747
9	Auger 54" right	Vis 54" droite	1	104748
10	Shear bolt / N.I.L.N. (auger) pkg-10	Boulon de séc. / É.G.N. (vis) pqt-10	2	104000
11	Bearing with set screw	Roulement à billes avec vis à pression	3	102755
12	Shear plate	Plaque de cisaillement	1	103933
13	Fan	Éventail	1	103932
14	Shear bolt / N.I.L.N. (fan) pkg-10	Boulon de séc./ É.G.N. (éven.) pqt-10	1	103999
15	Guard	Garde	1	104788
16	Belt guard	Garde-courroie	1	104789
17	Battery wire	Fil de la batterie	1	105390
18	Wire control box extension	Extension du fil de la boîte de contrôle	1	105400
19	Wire control box	Fil de la boîte de contrôle	1	105296
20	Bender	Tendeur	1	104785
21	Spring	Ressort	1	102592
22	Flat pulley	Poulie plate	1	102300
23	Flange washer	Rondelle à bride	1	102081
24	Electric motor	Moteur électrique	1	103378
25	Bracket	Fixation	1	104786
26	Oil lite bushing	Coussinet imprégné d'huile	1	103362
27	Spacer	Espaceur	2	103361

O/L = Obtain Locally

PARTS LIST SNOWBLOWER

Ref. Réf.	English description	Description française	Qty. Qté.	Part # Pièce #
28	Plate	Plaque	1	103363
29	Shim	Cale	2	104787
30	Rotation bushing	Coussinet de rotation	4	103946
31	Flangette	Flangette	2	102680
32	Oil lite bushing	Coussinet imprégné d'huile	2	102784
33	Cutting edge 54"	Racloir 54"	1	104427
34	Skid shoe	Patin	2	103188
35	Key 1/4" x 1/4" x 1 3/4"	Clé 1/4" x 1/4" x 1 3/4"	2	102327
36	Flangette	Flangette	2	102213
37	Box support	Support de la boîte	1	104756
38	Spacer	Espaceur	2	103368
39	Support bracket	Fixation du support	2	103068
40	Gear box support	Support de boîte d'engrenage	1	104746
41	Shaft 54"	Arbre 54"	1	104722
42	Lever	Levier	1	105401
43	Flat spring	Ressort plat	1	105402
44	Sleeve	Douille	1	105403
45	Control box	Boîtier de contrôle	1	105295
46	V-belt, BX-47	Courroie en V, BX-47	1	104790
47	Key 1/4" x 1/4" x 2"	Clé 1/4" x 1/4" x 2"	1	102922
48	Flange nut 1/4" n.c.	Écrou à bride 1/4" n.c.	5	O/L
49	Flange nut 5/16" n.c.	Écrou à bride 5/16" n.c.	12	O/L
50	Flange nut 3/8" n.c.	Écrou à bride 3/8" n.c.	9	O/L
51	Carriage bolt 5/16" n.c. x 3/4"	Boulon à carrosserie 5/16" n.c. x 3/4"	12	O/L
52	Stover lock nut 5/16" n.c.	Écrou de blocage 5/16" n.c.	6	O/L
53	Nylon insert lock nut 1/4" n.c. (thin)	Écrou à garniture de nylon 1/4" n.c.(mince)	3	O/L
54	Nylon insert lock nut 1/4" n.c.	Écrou a garniture de nylon 1/4" n.c.	2	O/L

O/L = Obtain Locally

PARTS LIST SNOWBLOWER

Ref. Réf.	English description	Description française	Qty. Qté.	Part # Pièce #
55	Nylon insert lock nut 5/16" n.c.	Écrou à garniture de nylon 5/16" n.c.	1	O/L
56	Nylon insert lock nut 3/8" n.c.	Écrou à garniture de nylon 3/8" n.c.	7	O/L
57	Nylon insert lock nut 7/16" n.c.	Écrou à garniture de nylon 7/16" n.c.	3	O/L
58	Hex. bolt 1/4" n.c. x 1/2"	Boulon hex. 1/4" n.c. x 1/2"	10	O/L
59	Hex. bolt 1/4" n.c. x 3/4"	Boulon hex. 1/4" n.c. x 3/4"	2	O/L
60	Hex. bolt 1/4" n.c. x 1 1/2"	Boulon hex. 1/4" n.c. x 1 1/2"	2	O/L
61	Hex. bolt 1/4" n.c. x 1 3/4"	Boulon hex. 1/4" n.c. x 1 3/4"	3	O/L
62	Hex. bolt 5/16" n.c. x 1/2"	Boulon hex. 5/16" n.c. x 1/2"	2	O/L
63	Hex. bolt 5/16" n.c. x 3/4"	Boulon hex. 5/16" n.c. x 3/4"	2	O/L
64	Hex. bolt 5/16" n.c. x 2 1/4" GR8	Boulon hex. 5/16" n.c. x 2 1/4" GR8	1	O/L
65	Hex. bolt 5/16" n.c. x 2 3/4"	Boulon hex. 5/16" n.c. x 2 3/4"	1	O/L
66	Hex. bolt 3/8" n.c. x 3/4"	Boulon hex. 3/8" n.c. x 3/4"	4	O/L
67	Hex. bolt 3/8" n.c. x 1"	Boulon hex. 3/8" n.c. x 1"	3	O/L
68	Hex. bolt 3/8" n.c. x 1 1/4"	Boulon hex. 3/8" n.c. x 1 1/4"	3	O/L
69	Hex. bolt 3/8" n.c. x 1 3/4"	Boulon hex. 3/8" n.c. x 1 3/4"	4	O/L
70	Hex. bolt 3/8" n.c. x 2"	Boulon hex. 3/8" n.c. x 2"	2	O/L
71	Hex. bolt 3/8" n.c. x 2 3/4"	Boulon hex. 3/8" n.c. x 2 3/4"	4	O/L
72	Hex. bolt 7/16" n.c. x 1 1/4"	Boulon hex. 7/16" n.c. x 1 1/4"	3	O/L
73	Hex. socket set screw 5/16" n.c. x 5/16"	Vis à pression hex. 5/16" n.c. x 5/16"	2	O/L
74	Flat washer 3/8" hole	Rondelle plate 3/8" trou	4	O/L
75	Flat washer 7/16" hole	Rondelle plate 7/16" trou	13	O/L
76	Tie wrap 8"	Attache de nylon 8"	6	O/L
77	Berco decal	Décalque Berco	1	102471
78	Decal danger auger	Decalque danger vis	1	105126
79	Decal warning safety	Decalque avertissement sécurité	1	105131
80	Decal read instructions	Decalque lire instructions	1	105130
81	Decal danger belts	Decalque danger courroies	1	105128
82	Specifications decal	Décalque spécifications	1	REF
83	Serial number	Numéro de série	1	REF

O/L = Obtain Locally

TORQUE SPECIFICATION TABLE

GENERAL TORQUE SPECIFICATION TABLE USE THE FOLLOWING TORQUES WHEN SPECIAL TORQUES ARE NOT GIVEN

NOTE: These values apply to fasteners as received from supplier, dry or when lubricated with normal oil. They do not apply if special graphited or moly disulphide greases or other extreme pressure lubricants are used. This applies to both UNF and UNC threads.

* Thick nuts must be used with grade 8 bolts

SEE Grade No.		2				5				8 *			
BOLT HEAD IDENTIFICATION MARKS AS PER GRADE NOTE MANUFACTURING MARKS WILL VARY		TORQUE				TORQUE				TORQUE			
BOLT SIZE		FOOT POUNDS		NEW TON-METERS		FOOT POUNDS		NEW TON-METERS		FOOT POUNDS		NEW TON-METERS	
Inches	Millimetre	Min.	Max.	Min.	Max.	Min.	Max.	Min.	Max.	Min.	Max.	Min.	Max.
1/4"	6.35	5	6	6.8	8.13	9	11	12.2	14.9	12	15	16.3	30.3
5/16"	7.94	10	12	13.6	16.3	17	20.5	23.1	27.8	24	29	32.5	39.3
3/8"	9.53	20	23	27.1	31.2	35	42	47.5	57	45	54	61	73.2
7/16"	11.11	30	35	40.7	47.4	54	64	73.2	86.8	70	84	94.9	113.9
1/2"	12.7	45	52	61	70.5	80	96	108.5	130.2	110	132	149.2	179
9/16"	14.29	65	75	88.1	101.6	110	132	149.2	179	160	192	217	260.4
5/8"	15.88	95	105	128.7	142.3	150	180	203.4	244.1	220	264	298.3	358
3/4"	19.05	150	185	203.3	250.7	270	324	366.1	439.3	380	456	515.3	618.3
7/8"	22.23	160	200	216.8	271	400	480	542.4	650.9	600	720	813.6	976.3
1"	25.4	250	300	338.8	406.5	580	696	786.5	943.8	900	1080	1220.4	1464.5

METRIC BOLT TORQUE SPECIFICATIONS							
		COARSE THREAD			FINE THREAD		
Size Screw	Grade No.	Pitch (mm)	Foot Pounds	Newton-Meters	Pitch (mm)	Foot Pounds	Newton-Meters
M6	4T	1.00	3.6 - 5.8	4.9 - 7.9	-	-	-
	7T		5.8 - 9.4	7.9 - 12.7		-	-
	8T		7.2 - 10	9.8 - 13.6		-	-
M8	4T	1.25	7.2 - 14	9.8 - 19	1.00	12 - 17	16.3 - 23
	7T		17 - 22	23 - 29.8		19 - 27	25.7 - 36.6
	8T		20 - 26	27.1 - 35.2		22 - 31	29.8 - 42
M10	4T	1.50	20 - 25	27.1 - 33.9	1.25	20 - 29	27.1 - 39.3
	7T		34 - 40	46.1 - 54.2		35 - 47	47.4 - 63.7
	8T		38 - 46	51.5 - 62.3		40 - 52	54.2 - 70.5
M12	4T	1.75	28 - 34	37.9 - 46.1	1.25	31 - 41	42 - 55.6
	7T		51 - 59	69.1 - 79.9		56 - 68	75.9 - 92.1
	8T		57 - 66	77.2 - 89.4		62 - 75	84 - 101.6
M14	4T	2.00	49 - 56	66.4 - 75.9	1.50	52 - 64	70.5 - 86.7
	7T		81 - 93	109.8 - 126		90 - 106	122 - 143.6
	8T		96 - 109	130.1 - 147.7		107 - 124	145 - 168
M16	4T	2.00	67 - 77	90.8 - 104.3	1.50	69 - 83	93.5 - 112.5
	7T		116 - 130	157.2 - 176.2		120 - 138	162.6 - 187
	8T		129 - 145	174.8 - 196.5		140 - 158	189.7 - 214.1
M18	4T	2.00	88 - 100	119.2 - 136	1.50	100 - 117	136 - 158.5
	7T		150 - 168	203.3 - 227.6		177 - 199	239.8 - 269.6
	8T		175 - 194	237.1 - 262.9		202 - 231	273.7 - 313
M20	4T	2.50	108 - 130	146.3 - 176.2	1.50	132 - 150	178.9 - 203.3
	7T		186 - 205	252 - 277.8		206 - 242	279.1 - 327.9
	8T		213 - 249	288.6 - 337.4		246 - 289	333.3 - 391.6

OPTIONS & ACCESSORIES

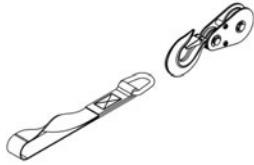

#700269
LIFT CONNECTION KIT
 Reduces the effort and the speed required by the winch to lift the accessory .



#700260
SNOW DRIFT CUTTER
 Slices through high snow drifts to facilitate and increase snow intake. Package of 2.

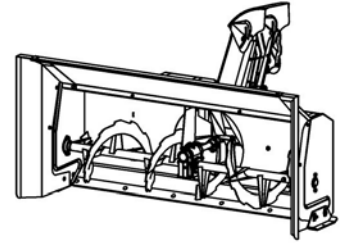

#700461
EXTENSION AND SIDE WIDENING ANGLES KIT
 Widens the snowblower to 60"

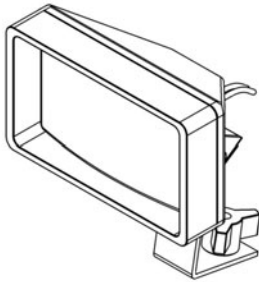

#700456
LIGHT KIT
 Better visibility for night time use

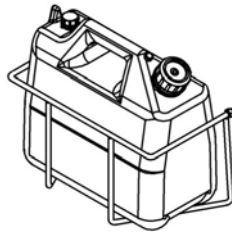

#700462
GAS TANK KIT
 Handy for easy re-fuelling

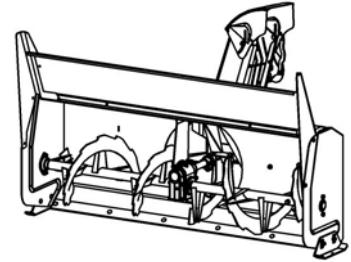

#700473
EXTENSION
 Adds 8" to the height of the snowblower
REQUIRES #700260

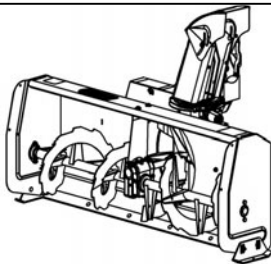

#700480
48" VERSATILE SNOWBLOWER
 For ATV

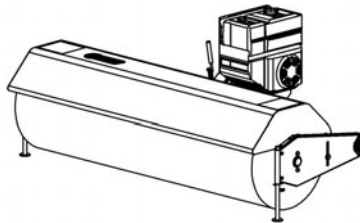

#700448
60" ROTARY BROOM
 For ATV or UV

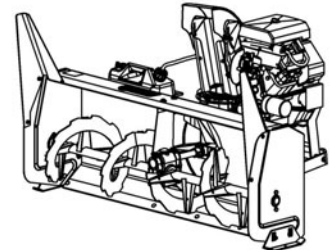

#700360
54" PRESTIGE SNOWBLOWER
 For ATV

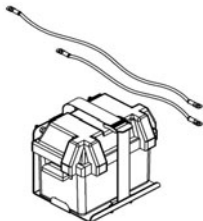

#700524
SUPPORT FOR BATTERY
(BATTERY NOT INCLUDED)
 For ATV or UV

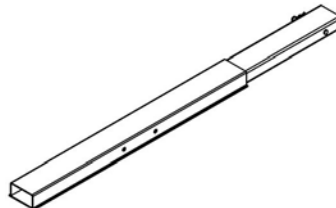

SUBFRAME EXTENSION
#700485
 For bigger vehicle



***WHEN PERFORMANCE
& DEPENDABILITY
ARE NON NEGOTIABLE!***

Bercomac Limitée
92, Fortin North, Adstock, Quebec, Canada, G0N 1S0

WWW.BERCOMAC.COM

PRINTED IN CANADA

(ORIGINAL NOTICE)