

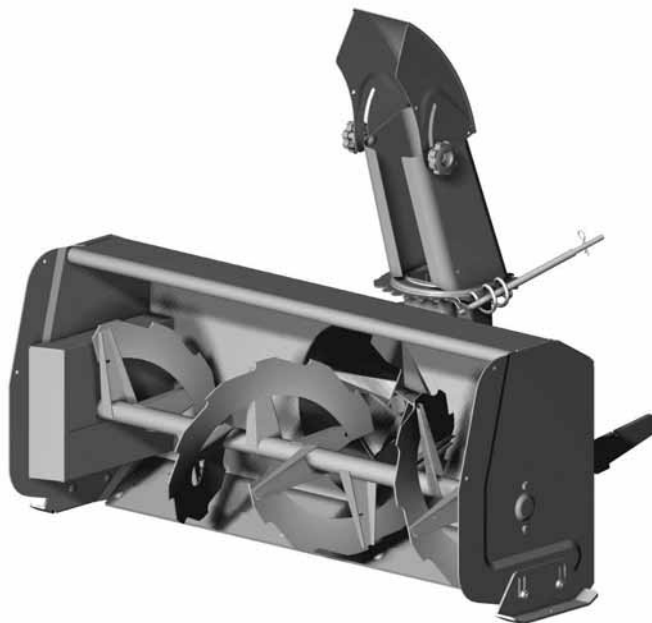

OWNER'S MANUAL
Model Number
700465-3



Berco
Compact Two Stage 40" Snowblower
for electric lift
FITS ON LAWN AND YARD TRACTORS

- * ASSEMBLY
- * OPERATION

- * REPAIR PARTS
- * MAINTENANCE

WARNING:
READ & FOLLOW ALL SAFETY RULES & INSTRUCTIONS BEFORE
OPERATING YOUR EQUIPMENT



LIMITED WARRANTY

Conditions and Products Covered:

BERCOMAC guarantees any part of the product or accessory manufactured by BERCOMAC and found in the reasonable judgment of BERCOMAC to be defective in material and or workmanship will be repaired or replaced by an authorized dealer without charge up to our maximum labor rates and pre-established times. For replacement parts only standard ground freight services are covered. This warranty extends to the original retail purchaser only and is not transferable to any subsequent purchasers. This warranty applies to the products bought and used in North America.

Warranty Period

(from date of the original retail purchase)

- Residential use: 1 year
- Semi-commercial, professional or rental use: 90 days

Exceptions Noted Below; the following items are guaranteed by the original manufacturer and have their own warranty, conditions and limited time:

- Tire Chains: 90 days
- Engines: Will vary as per the manufacturer
Please refer to the engine manufacturer's warranty statement included with the unit. BERCOMAC is not authorized to handle warranty adjustments on engines.

Items and Conditions NOT Covered:

This warranty does not cover the following:

- Pick-up or delivery charges or in-home services fees.
- Any damage or deterioration of the unit, parts and or finish of these due to normal use, wear and tear, or exposure.
- Cost of regular use or maintenance service or parts, such as gas, oil, lubricants, tune-up parts, and adjustments.
- Any part or accessory which has been altered, modified, misused, neglected, accidentally damaged or not properly installed, maintained, stored or repaired not in accordance with the instructions in the owner's manual.
- Repair due to normal wear and or any wear items such as shear pins, bolts, belts, etc.
- Expedited freight fee services for replacement parts.
- Shear bolts and shear pins are to be considered as a preventive measure not as an assured protection, any damages resulting from the lack of shear bolts breakage are not covered.
- Damages due to product being installed on a vehicle other than stipulated in owner's manual.

NOTE: All warranty work must be performed by an authorized dealer using original (manufacturer) replacement parts.

NOTE: Bercomac reserves the right to change or improve the design of any part or accessory without assuming any obligation to modify any product previously manufactured.

Instructions for Obtaining Warranty Services:

Contact dealer where equipment was purchased or any other BERCO service dealer to arrange service at their dealership. Requests for warranty claims must be carried out through the same distribution network used to purchase the product. Don't forget to bring your proof of purchase (sales receipt) to the BERCOMAC dealer.

Owner's Responsibilities:

BERCOMAC's defective equipment or part must be returned to an authorized dealer within the warranty period for repairs. In the event that defective merchandise must be returned to manufacturer for repairs, freight fees are prepaid and a written authorization from BERCOMAC must be obtained by dealer prior to the shipment. This warranty extends only to equipment operated under normal conditions. To validate a warranty claim, it is the user's responsibility to maintain and service the unit as specified in the owner's manual or to have the unit serviced at their dealer at their expense.

General Conditions:

The sole liability of BERCOMAC with respect to this warranty shall be strictly and exclusively repair and replacement as mentioned herein. BERCOMAC shall not have any liability for any other costs, loss or damage, including but not limited to, any incidental or consequential loss or damage. Taking advantage of the warranty does not in any way extend the length or renewal of the warranty.

In particular, without being limited to, BERCOMAC shall have no liability or responsibility for:

- Travel time, overtime, after hours time or other extraordinary repair charges or relating to repairs and or replacements outside of normal business hours.
- Rental of like or similar replacement equipment during the period of any, repair or replacement work.
- Any communicating or travel charges.
- Loss or damage to person or property other than that covered by the terms of this warranty.
- Any claims for lost revenue, lost profit or any similar costs as a result of damage or repair.
- Attorney's fees.

BERCOMAC's responsibility in respect to claims is limited to making the required repairs or replacement without charge up to our maximum labor rates and pre-established times and no claim of breach of warranty shall be cause for cancellation or rescission of the contract of sale of any product or accessory. In no event recovery of any kind be greater than the amount of the purchase price of the product sold.

This warranty gives you specific legal rights. You may also have other rights, which vary from state to state.

TABLE OF CONTENTS

	PAGE
INTRODUCTION	2
SAFETY PRECAUTIONS	3
SAFETY DECALS	5
ASSEMBLY	
Tools Required	6
Step 1: Snowblower preparation	6
Step 2: Subframe preparation	8
Step 3: Snowblower Installation	9
OPERATION	
Snowblower Operation	11
Controls	11
MAINTENANCE	
Adjustments	12
Lubrication	12
Cutting Edge Maintenance	12
Clearing a Clogged Discharge Chute	12
Shear Bolt & Shear Pin Replacement	12
Belt Installation, Adjustment and Replacement	13
DISMOUNTING & STORAGE	
Snowblower Dismounting	14
Storage	14
TROUBLESHOOTING	15
TORQUE SPECIFICATION TABLE	20
PARTS BREAKDOWN AND PARTS LIST	
Chute with rotation system	21
Snowblower	23
OPTIONS & ATTACHMENTS	27

INTRODUCTION

TO THE PURCHASER

This new accessory was carefully designed to give years of dependable service. This manual has been provided to assist in the safe operation and servicing of your attachment.

NOTE: All photographs and illustrations in the manual may not necessarily depict the actual models or attachment, but are intended for reference only and are based on the latest product information available at the time of publication.

Familiarize yourself fully with the safety recommendations and operating procedures before putting the machine to use. Carefully read, understand and follow these recommendations and insist that they be followed by those who will use this attachment.



THIS SAFETY ALERT SYMBOL IDENTIFIES AN IMPORTANT SAFETY MESSAGE IN THIS MANUAL THAT HELPS YOU AND OTHERS AVOID PERSONAL INJURY OR EVEN DEATH. DANGER, WARNING, AND CAUTION ARE SIGNAL WORDS USED TO IDENTIFY THE LEVEL OF HAZARD. HOWEVER, REGARDLESS OF THE HAZARD, BE EXTREMELY CAREFUL.

DANGER: Signals an extreme hazard that will cause serious injury or death if recommended precautions are not followed.

WARNING: Signals a hazard that may cause serious injury or death if the recommended precautions are not followed.

CAUTION: Signals a hazard that may cause minor or moderate injury if the recommended precautions are not followed.

Record your attachment serial number and purchase date in the section reserved below (there is no serial number on the subframe). Your dealer requires this information to give you prompt, efficient service when ordering replacement parts. Use only genuine parts when replacements are required.

If warranty repairs are required please present this registration booklet and original sales invoice to your selling dealer for warranty service.

This manual should be kept for future reference.

Please check if you have received all the parts for your kit with the list of the bag and the list of the box.

SERIAL NUMBER : _____
(IF APPLICABLE)

MODEL NUMBER: _____

PURCHASE DATE : _____



SAFETY PRECAUTIONS



Careful operation is your best insurance against an accident. Read this section carefully before operating the vehicle and accessory. This accessory is capable of amputating hands and feet and throwing objects. Failure to observe the following safety instructions could result in serious injury. All operators, no matter how experienced they may be, should read this and other manuals related to the vehicle and accessory before operating. It is the owner's legal obligation to instruct all operators in safe operation of the accessory.

GLOSSARY:

In this manual, right and left sides are determined by sitting on the seat of the vehicle facing forward.

In this manual, "accessories" means attachments (snowblower, rotary broom, blade etc.) that you install on the vehicle (lawn tractors, A.T.V. s etc).

TRAINING:



This symbol, "Safety Alert Symbol", is used throughout this manual and on the accessory's safety labels to warn of the possibility of serious injury. Please take special care in reading and understanding the safety precautions before operating the vehicle and accessory.

1. Read this owner's manual carefully. Be thoroughly familiar with the controls and proper use of the vehicle and accessory. Know how to stop the unit and disengage the controls quickly.
2. Never allow children to operate the vehicle nor the accessory. Never allow adults to operate the vehicle nor the accessory without proper instructions.
3. No one should operate the vehicle nor the accessory while intoxicated or while taking medication that impairs the senses or reactions.
4. Keep the area of operation clear of all people, particularly small children and pets.
5. Never start or operate the accessories except from the operator's station on the power unit except if this is impossible.
4. Handle fuel with care, it is highly flammable.
 - a) Use approved fuel container.
 - b) Never add fuel to a running engine or hot engine.
 - c) Fill fuel tank outdoors with extreme care. Never fill fuel tank indoors.
 - d) Never fill containers inside a vehicle, or on a truck or a trailer bed with a plastic liner. Always place containers on the ground, away from your vehicle, before filling.
 - e) When practical, remove gas-powered equipment from the truck or trailer and refuel it on the ground. If this is not possible, then refuel such equipment on a trailer with a portable container, rather than from a gasoline dispenser nozzle.
 - f) Keep the nozzle in contact with the rim of the fuel tank or container opening at all times, until refueling is complete. Do not use a nozzle lock-open device.
 - g) Replace fuel cap securely and wipe up spilled fuel.
 - h) If fuel is spilled on clothing, change clothing immediately.
5. Never attempt to make any adjustments while the engine (motor) is running (except when specifically recommended by manufacturer).
6. Let the vehicle and accessory adjust to outdoor temperatures before using.
7. Never use an accessory without proper guards, plates, or other safety protective devices in place
8. Always make sure to wear the appropriate safety equipment required (glasses, muffs, mask...) for each type of product. See operation section.
9. Always make sure of having safe traction on the vehicle by using the recommended accessories (chains, A.T.V. tracks, counterweights...). See operation section.
10. Always make sure all components are correctly installed. (driveline securely attached and locked at both ends, belts properly installed...)
11. If applicable, always handle the winch cable with thick leather gloves.
12. **Never modify the accessory or any part without the written consent from the manufacturer.**

PREPARATION:

1. Thoroughly inspect the area where the accessory is to be used and remove door mats, all foreign objects and the like.
2. For motorized accessories, disengage all clutches and shift into neutral before starting engine.
3. Do not operate the accessory without wearing adequate winter outer garments. Avoid loose fitting clothing that can get caught in moving parts. Wear footwear that will improve footing on slippery surfaces.



SAFETY PRECAUTIONS



OPERATION:

1. Do not put hands or feet near, under or inside rotating parts.
2. Exercise extreme caution when operating on or crossing gravel drives, walks or roads. Stay alert for hidden hazards or traffic. Do not carry passengers.
3. After striking a foreign object, stop the engine (motor), disconnect the wire from the spark plug(s) and keep wire away to prevent accidental starting. Thoroughly inspect the accessory for any damage and repair damage before restarting and using the accessory.
4. If the unit should start to vibrate abnormally, stop the engine (motor) and check immediately for the cause. Vibration is generally a warning of trouble.
5. Take all possible precautions when leaving the vehicle unattended. Disengage the power take-off, lower the attachment, place the transmission into neutral, set the parking brake, stop the engine and remove the ignition key.
6. Do not run the engine indoors, except when starting the engine and for transporting in or out of the building. Do not operate or let motor run in a storage area without ventilation because gas contains carbon monoxide which is odorless, colorless and can cause death.
7. Never use the accessories across the face of slopes, go from top to bottom. Exercise extreme caution when using equipment on slopes. Do not attempt to clear a steep slope.
8. Never tolerate bystanders in the working zone. Never use an accessory in the direction of bystanders, it might throw gravel or debris that can hurt people or damage property.
9. Never operate the accessory at high transport speeds on slippery surfaces. Use care when backing up.
10. Do not carry passengers.
11. Disengage power to the accessory when it is transported or not in use.
12. Never operate the accessory without good visibility or light.
13. Keep the accessory away from heat sources or flames.
14. If applicable, never handle the winch cable or hook while in tension.

MAINTENANCE AND STORAGE

1. When cleaning, repairing or inspecting the vehicle and accessory: stop the engine, set brake, remove ignition key, and wait that all moving parts have stopped. For gasoline engine, disconnect wire from the spark plug(s) and keep wire away to prevent accidental starting.
2. Check all the bolts and components at frequent intervals to make sure that they are properly tightened.
3. Never store a motorized accessory with fuel in the fuel tank inside a building where ignition sources are present such as hot water and space heaters, clothes dryers, and the like. Allow the engine to cool before storing in any enclosure.
4. Always refer to the owner's manual when you store the accessory and vehicle for a prolonged or an unspecified length of time.
5. Maintain or replace safety and instruction labels, as necessary.
6. For winter accessories, (if applicable), let the engine run for a few minutes after clearing snow in order to prevent the rotary parts from freezing.
7. Inspect the vehicle's and accessory's air filter (if applicable) every day. Clean it or replace it as necessary. Change the oil more often when working in dusty conditions. See the vehicle's and accessory's owner's manual.

TRANSPORT

1. Review Transport Safety instructions in vehicle manual before moving.
2. Check with local authorities regarding transport on public roads. Obey all applicable laws and regulations.
3. Make sure all lights and reflectors that are required by the local highway and transport authorities (example : SMV (Slow Moving Vehicle)) are in place, are clean, and can be seen clearly by all overtaking and oncoming traffic.
4. Never have the equipment in operation during transport.
5. Always travel at a safe speed.



SAFETY DECALS



**REPLACE IF DECALS ARE DAMAGED
SEE PARTS BREAKDOWN FOR DECAL LOCATION**

DECAL #105126



To avoid serious injury:
Keep hands, feet & clothing away from rotating auger while engine is running.

DECAL #105127



To avoid serious injury:
Keep hands out of this discharge chute while engine is running.

DECAL #105128



To avoid injury from drive belt:
Keep hands, feet & clothing away.
Do not attempt to install or remove drive belt without reading owner's manual.

DECAL #105130

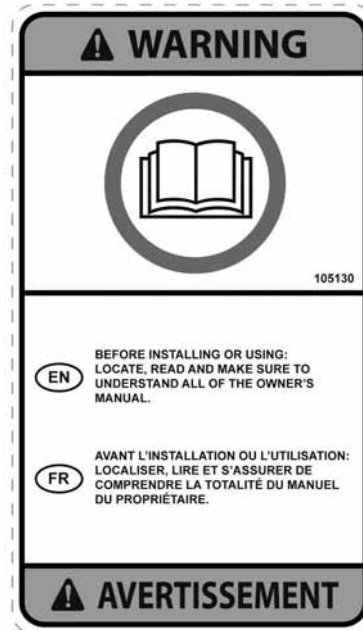

Before installing or using:
Locate, read and make sure to understand all of the owner's manual.

DECAL #105131

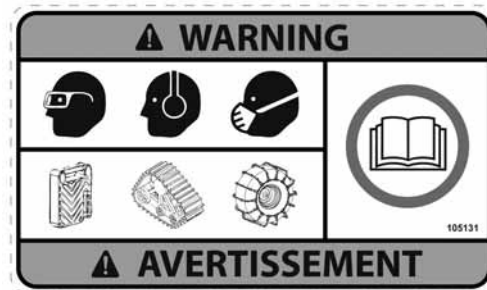

Refer to owner's manual about wearing safety glasses, ear muffs and mask.
Refer to owner's manual for use of counter weights, cat tracks and tire chains.

ASSEMBLY

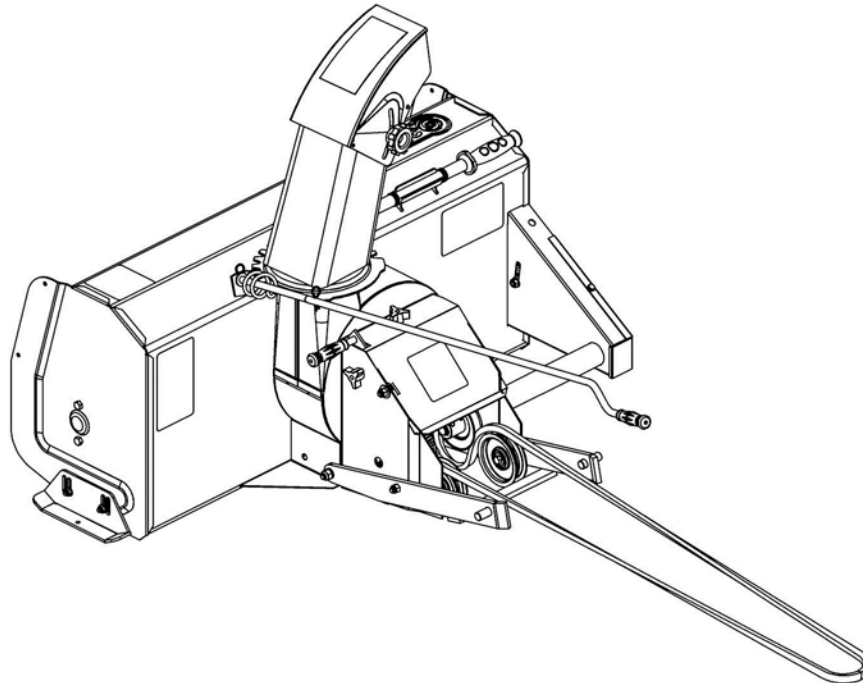

Overall view

TOOLS REQUIRED:

No tools are required.

STEP 1

SNOWBLOWER PREPARATION:

Refer to parts breakdown section for parts identification.

Install the chute (item 2).		
Item #	Description	Action
1	Rotation ring	Install over opening.
2	Chute	Place as shown, turn to lock into place.

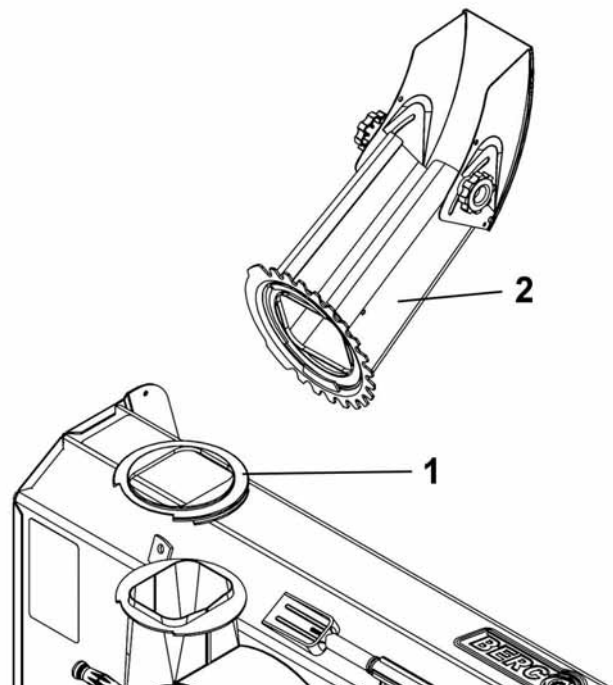

Install chute

ASSEMBLY

Install rotation worm (item 2).

Item #	Description	Action
1	Flat washer 7/16", (2)	Install on each side of rotation support.
2	Rotation worm	Install in rotation support.
3	2.5mm hair pin	Secure rotation worm shaft in support.

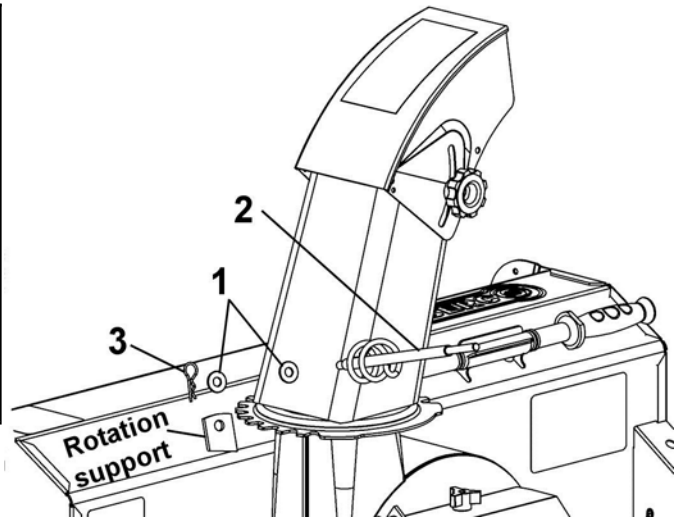

Install rotation worm

Prepare handle (item 3).

Item #	Description	Action
1	Hand grip	Install on handle.
2	Hair pin	Install on handle.
Store these parts safely until you install the snowblower.		

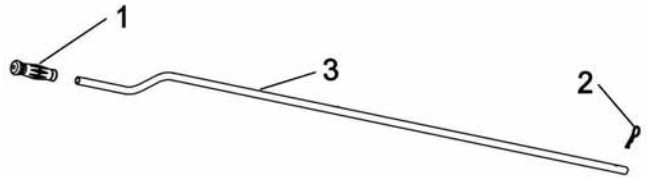

Prepare handle

ASSEMBLY

STEP 2

SUBFRAME PREPARATION:

You must install the subframe and the drive mechanism before continuing the installation of the snowblower.

Installation of the hitch plate :

This step is not necessary if the subframe is already equipped with a hitch plate.

Step A :

Remove the bolts and nuts holding the winch to the female hitch assembly. (item 1)

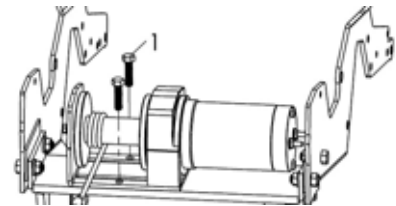

Step B :

Install the winch on the female hitch using the bolts 5/16" x 1-1/4" GR8 as illustrated (1).

Install the hitch plate as illustrated (2).

Insert the nylon lock nuts 5/16" as illustrated (3), tighten firmly.

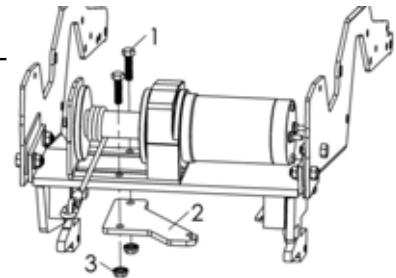

Installation of the pulley :

Step A:

Pass the cable (1) through the pulley assembly (2) as illustrated.

Attach the chain link of the cable (1) to the attaching plate (3) and secure it with the hair pin (4) as illustrated.

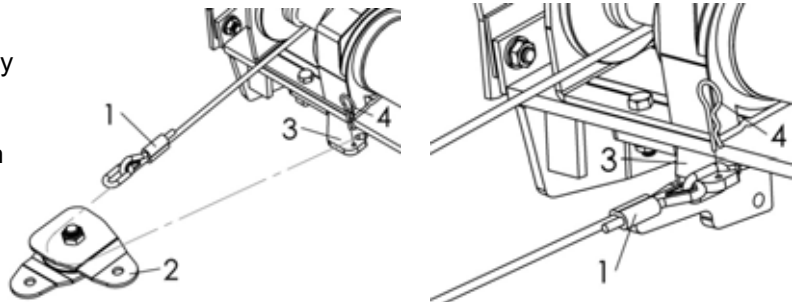

Step B:

Close the pulley assembly (1) around the cable using the shackle (2).

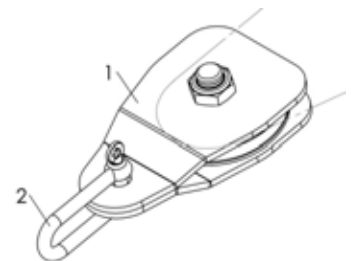

INSTALLATION

STEP 3 SNOWBLOWER INSTALLATION:

You must install the subframe and drive mechanism before continuing to install the snowblower.



DANGER



TO PREVENT INJURIES:

Stop the motor.

Apply parking brake.

Remove the ignition key.

Disconnect the wire from the spark plug(s) and keep away from spark plug(s) to prevent accidental starting.

Attach the snowblower to the subframe as shown.

Make sure the snowblower is pushed in until locked into place by the lock (item 1).

Install belts.

NOTE: See the belt installation instructions in the Maintenance section.

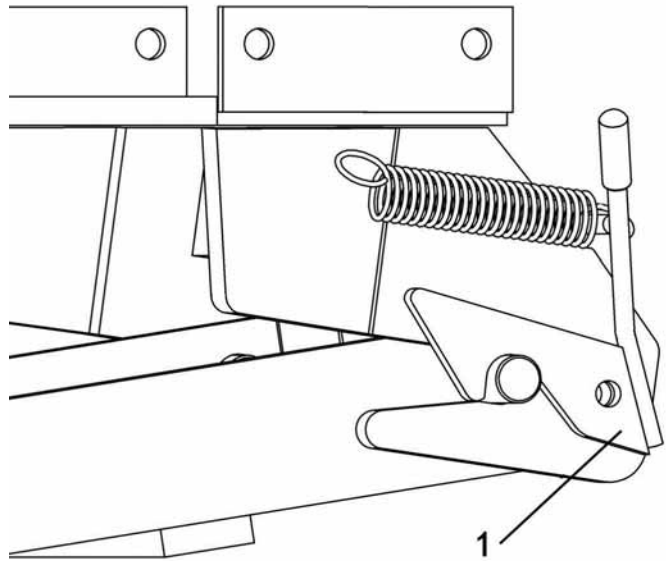

Insert the snowblower in the lock.



CAUTION



The belt tension arm & needs to be held firmly while displacing to prevent injury.



CAUTION



Never use the snowblower without the belt guard.

Lift cable installation:

After installing the belt, hook the shackle (item 1) to the hook (position A) and secure with a 2.5mm hair pin (item 2).

NOTE: Make sure the head of the shackle pin is down to prevent any contact with the pulley.

NOTE: For your information, it is possible to attach the winch hook in position B by removing the pulley.

Familiarize yourself with the winch control and make sure the cable stays wrapped from the bottom of the drum of the winch. See picture of the winch in the subframe's owner manual.

Lift and lower the snowblower using the switch.

When lowering the accessory, release the switch of the winch control as soon as the accessory touches the ground.

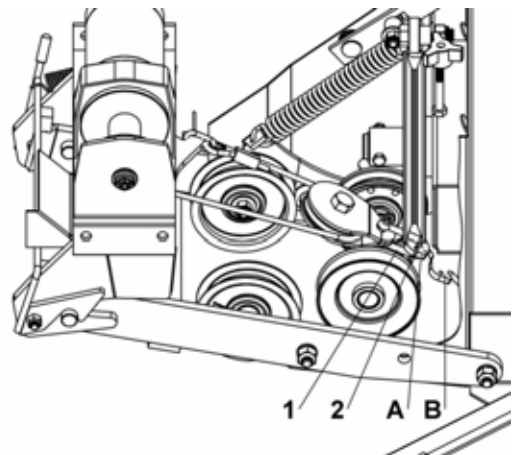

Install the cable

INSTALLATION

Install handle (item 2).		
Item #	Description	Action
1	Hair pin	Remove from handle.
2	Handle	Insert in handle support.
3	Rotation worm	Insert in handle and secure with hair pin.

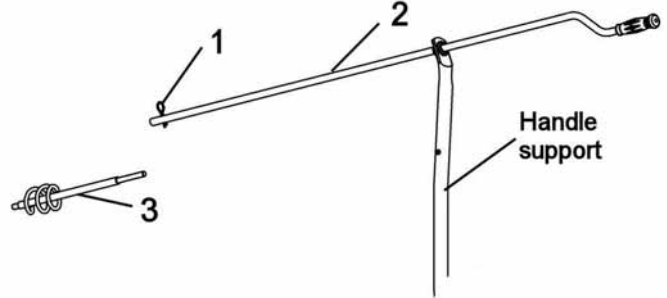

Install handle

OPERATION



WARNING



Read the tractor Owner's Manual carefully. Be thoroughly familiar with the controls & proper use of the attachment. Know how to stop the attachment quickly.

SNOWBLOWER OPERATION

- Make sure the snowblower is clear of snow before engaging the snowblower.
- Make sure that the auger and impeller operate freely.
- Start the tractor engine.
- Before engaging the snowblower drive, always have the engine running at medium R.P.M.
- When removing snow, do not use the snowblower as a dozer blade to push snow. Allow snowblower to ingest snow at its own speed. If the speed of your tractor is too fast, the snowblower may become overloaded and plug.

IMPORTANT: USE FULL ENGINE R.P.M. WHEN REMOVING WET OR STICKY SNOW. LOW R.P.M. WILL TEND TO PLUG THE CHUTE.

CLEARING A CLOGGED DISCHARGE CHUTE:



DANGER



Hand contact with the rotating impeller inside the discharge chute is the most common cause of injury associated with snowblowers. Never use your hand to clean out the discharge chute.

-Do not attempt to clear plugged chute, auger or fan of snow while the snowblower's engine is running.

-Disengage snowblower.

-Lower snowblower to the ground and set parking brake.

-SHUT THE ENGINE OFF & REMOVE KEY!

-Wait 10 seconds to be sure that all moving parts such as the impeller blades have stopped moving.

-Disconnect wire from the spark plug(s) and keep wire away to prevent accidental starting.

Always use the clean-out tool (chute shovel) supplied with this snowblower, NOT YOUR HANDS

VERIFY TIRE PRESSURE:

Tire pressure must be even on both sides of tractor according to the owner's manual of the vehicle.



WARNING



TO PREVENT INJURIES AND FOR MORE TRACTION WHEN USING AN ATTACHMENT:

-Rear counterweight of 100 lbs. minimum is required to counterbalance the attachment's weight.

-Manufacturer approved tire chains are required.

-Do not operate on a slope greater than 10°.

-When dismounting the attachment remove rear counterweights.

-Ear muffs and safety glasses are recommended.

CONTROLS

CHUTE ROTATION

The chute rotation handle is located to the left of steering wheel. Turning the handle in a clockwise direction, the discharge chute will turn in a clockwise direction or vice versa.

CHUTE DEFLECTOR

Set the angle of the deflector according to the distance the snow must be thrown. To change the deflector angle, loosen the two deflector knobs & adjust the deflector to the appropriate angle.

SNOW REMOVAL

When removing snow, do not use the snowblower as a dozer blade to push snow. Allow snowblower to ingest snow at its own speed. If the speed of your tractor is too fast, the snowblower may become overloaded and plug. For best results, raise the snowblower and remove a top layer of snow. A second pass with the snowblower will remove the remaining snow.

MAINTENANCE

Refer to parts breakdown section for parts identification.



WARNING



TO PREVENT INJURIES:

Stop the motor.
Apply parking brake.
Remove the ignition key.
Disconnect the wire from the spark plug(s) and keep away from spark plug(s) to prevent accidental starting.



CAUTION



TO PREVENT INJURIES:

- Check mounting bolts at frequent intervals for proper tightness in order to prevent costly repairs.
- Make sure your snowblower is in safe working condition.
- Provide adequate blocking before working under snowblower when in raised position.

ADJUSTMENTS

SKID SHOE ADJUSTMENT:

LEVEL PAVED SURFACE: Adjust skid shoes to allow 3/16" to 1/4" or 5mm to 7mm clearance (A) between cutting edge and surface.

UNEVEN OR GRAVEL SURFACE: Adjust skid shoes to allow 1/2" to 5/8" or 13mm to 16mm clearance (A) between cutting edge and surface.

CHAIN ADJUSTMENT:

Auger drive chain: Set chain tension leaving 1/2" deflection in chain span. Retighten hex bolt securely.

LUBRICATION

Apply oil at all pivot points.

Drive Chains: Lubricate with chain saw chain lubricant every eight hours of operation.

Chute Rotation System: Oil chute base, rotation worm every eight hours of operation.

IMPORTANT: When aligning or replacing the snowblower pulley (item 4), You must clean the parts and apply some "Loctite" 2760 on the key of the pulley and the set screws of the bearing and pulley. Tighten firmly.

CUTTING EDGE MAINTENANCE

Verify from time to time the wear on the cutting edge to make sure you do not wear out the base of the snowblower's frame. This cutting edge is reversible.

SHEAR BOLT & SHEAR PIN REPLACEMENT

Shear bolts and shear pins are to be considered a preventive measure and not an assured protection. Operator vigilance is required. Thoroughly inspect the areas where the snowblower is to be used and remove all foreign objects.

Fan Shear Bolt Replacement:

The fan is protected by a special shear bolt with two grooves. If you hit a foreign object or ice, the shear bolt is designed to break in two upon absorbing impact. The fan will stop turning. This is to avoid damage to the fan or to the snowblower. Replace only with original parts.

Auger Shear Pin Replacement:

The auger is protected by a special nylon shear pin. If you hit a foreign object or ice, the shear pin is designed to break in two upon absorbing impact. The auger will stop turning. This is to avoid damage to the auger or the snowblower. Replace only with original parts.

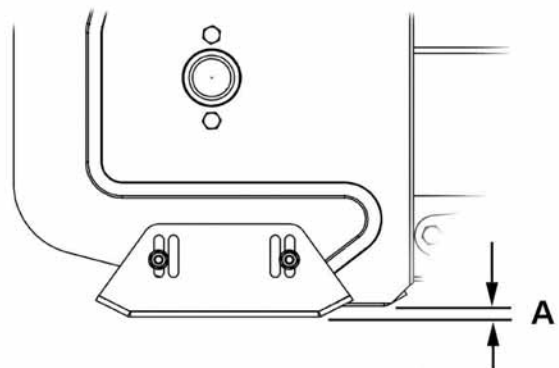
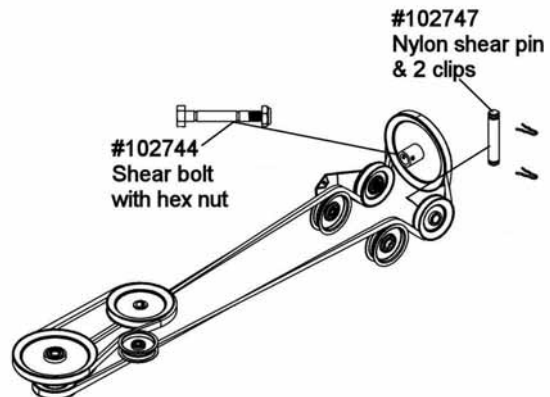

Adjust skid shoes

MAINTENANCE

BELT INSTALLATION, ADJUSTMENT, AND REPLACEMENT:



WARNING



The belt tension arm is spring loaded & needs to be held firmly while displacing to prevent injury.

SNOWBLOWER BELT:

- a) Lower the snowblower to the ground.
- b) Remove the belt guard.
- c) Remove tension on the belt by lowering the tension arm (item 1)
- d) Loosen the knob (item 2) on the bracket that holds the bearing (item 3).
- e) Install the belt as shown.
- f) Adjust the bracket by pushing on the bearing (item 3) to apply a slight pressure on the back of the belt (just enough to hold the belt in place). It is normal that the bearing is off centre (towards the vehicle) on the pulley. Just make sure that it does not come into contact with the wall of the pulley.
- g) Tighten firmly with the knob.
- h) Apply tension on the belt by pulling up the tension arm (item 1). To obtain the proper tension, the distance between the coils of the spring (item 6) should be .25" (1/4") approx.
If not, remove the bolt, sleeve and the spring from the original hole and reinstall them in the second hole (item 5). This will apply more tension on the belt helping to prevent it from slipping in the pulleys.
- i) Engage the snowblower for a few seconds under supervision. Stop the engine. Inspect the belt to make sure it does not interfere with any parts; that it is well inserted in the pulleys and that it has not flipped on it's side while still on the pulleys. The V of the belt **must be in** the V of the pulleys. The back of the belt **must rest on** the flat pulleys (D) as shown.
- j) Reinstall the belt guard.
- k) Use genuine belts only, they are specifically fabricated for this application.

NOTE: There must be a good tension on the belt at all times. If spring is damaged or stretched, you must replace it.

DRIVE MECHANISM BELT:

See subframe manual for belt replacement instructions.

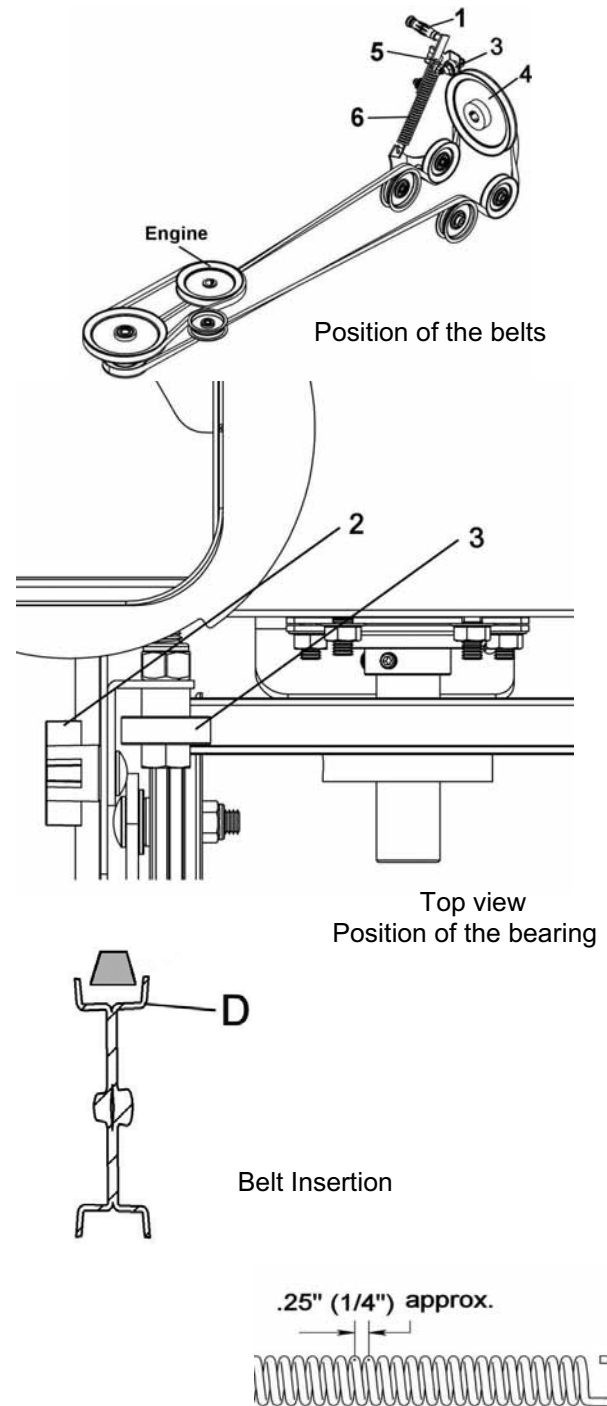

DISMOUNTING & STORAGE

SNOWBLOWER DISMOUNTING



CAUTION



The belt tension is spring loaded & needs to be held firmly while displacing to prevent injury.

- a) Remove the hair pin and the handle from the chute rotation.
- b) Remove the belt guard.
- c) Unhook the winch cable from the snowblower.
- d) Release the tension on the belt by displacing the tension arm backwards. Remove the belt from the engine pulley under the tractor.
- e) Remove the snowblower by activating the latch of the female hitch.
- f) Reinstall the belt guard.

STORAGE

- a) Clean snowblower thoroughly and repaint all parts from which paint has worn.
- b) List the replacement parts that will be needed to be replaced before the next season.
- c) Follow the instructions in the Lubrication section.
- d) Store the snowblower in a dry place.



CAUTION



Never use the snowblower without the belt guard.

TROUBLESHOOTING

* Please refer to parts breakdown section for parts identification.

PROBLEM	POSSIBLE CAUSES	CORRECTIVE ACTION
Auger stops turning.	Nylon shear pin is probably broken.	Replace shear pin.
	The reduction chain is broken or the connecting link is unlocked.	Remove both chain guards. Inspect & repair chain if needed.
Fan stops turning.	Shear bolt is probably broken.	Replace shear bolt.
Snowblower stops turning.	One of the two belts is probably damaged or broken.	Check both belts and replace damaged belt(s).
Belt snapping, shredding or burning or worn in a specific place.	Lack of tension on belt.	Adjust manual clutch cable or replace springs if stretched.
	Snowblower engaged when plugged.	Make sure the auger & the fan are not frozen or plugged before engaging.
	Not original belts.	Always use original belts.
	Worn belt. Belt may be worn causing a slack.	Inspect the belt. Replace if required.
	Not original shear bolts.	Use original shear bolts
	Imperfections in pulleys.	Verify if the pulleys are damaged. Verify that pulleys are smooth, without rust spots. Sand down the pulleys or replace them.
	Interference.	Make sure that belt does not come into contact with any other part, bolts, guides etc... when engaged.
	Belt has flipped on its side.	When installing new belt, have snowblower run between 20 to 40 seconds. Turn everything off and verify that belt has not turned on its side. If so, remove belt and re-install in opposite fashion to rectify the bad twist the belt has taken.
Belt comes off pulley or flips off	Bearing which acts as a belt guide is not well positioned.	Guides must be in proper position to guide the belt into the pulleys properly. See belt adjustment section.
	Defective pulley.	Replace the pulley
Chute plugs easily.	Tractor engine turning too slowly.	Run engine at full throttle during snowblowing operation.
	Advancing too quickly with tractor.	Allow snowblower to ingest snow at its own speed.
Chute rotation is difficult.	Dirt or ice may be underneath chute.	Dismount chute by removing the rotation worm. Turn the chute completely towards the rear and it will disconnect from base. Clean the base of chute and the rotation ring. Lubricate & re-install.

TROUBLESHOOTING

* Please refer to parts breakdown section for parts identification.

PROBLEM	POSSIBLE CAUSES	CORRECTIVE ACTION
Snowblower digs into ground.	Ground is not frozen or too soft.	Adjust skid shoes lower so they may better support the snowblower. If problem persists, change skid shoes for heavy duty skid shoes (option #700243) which cover more surface and prevents snowblower from digging.
Snowblower does not raise evenly.	Tire pressure uneven from one side to another.	Verify and adjust tire pressure:
Snowblower vibrates or is abnormally noisy.	Damaged pulley.	Replace pulley.
	Damaged bearing.	Replace bearing.
	Damaged fan.	Dismount & repair or replace fan.
	Damaged auger.	Replace auger.

TROUBLESHOOTING

* Please refer to parts breakdown section in subframe manual for parts identification.

PROBLEM	POSSIBLE CAUSES	CORRECTIVE ACTION
Winch runs backwards.	Winch wires reversed.	Recheck wiring.
	Switch wires reversed.	Recheck wiring.
	Switch installed incorrectly.	Check switch installation.
	Battery wires reversed.	Recheck wiring.
	Winch cable is not winded up from the bottom of spool.	Wind winch cable from underneath.
Winch will not operate or runs in one direction only.	Vehicle's ignition switch is at OFF position.	Turn vehicle's ignition switch at ON position.
	Broken wires or bad connection.	Check for poor connections.
	Control switch is inoperative.	Replace control switch.
	Relay or breaker is damaged.	Replace the relay or breaker.
	Limit switch is damaged.	Replace limit switch.
	Winch is damaged.	Replace or repair winch.
Winch runs but with insufficient power or line speed.	Weak battery.	Recharge or replace battery. Check charging system
	Poor battery connection.	Check battery terminals for corrosion. Clean when required.
	Winch is damaged.	Replace or repair winch.

TROUBLESHOOTING

* Please refer to parts breakdown section in subframe manual for parts identification.

PROBLEM	POSSIBLE CAUSES	CORRECTIVE ACTION
The shackle between the accessory and the lifting pulley is broken or the back of the snowblower is deformed.	Excessive repeated impacts.	Replace shackle and / or straighten the back of the snowblower. After repairs, drive slowly crossing obstacles, to avoid putting excessive tension on the shackle.
	Excessive high lifting overload. Lifting too high when snowblower is covered in snow.	Replace shackle and / or straighten the back of the snowblower. After repairs, take care to lift the snowblower when it is free to move (not covered in ice, ...), and not covered with snow.
The shackle between the accessory and the pulley lift is slightly distorted.	Impacts	Use shackle as it is, if you need to replace the cable or remove the pulley, remove the bolt from the pulley. Drive slowly over obstacles.
	Lifting when overloaded with snow.	Use shackle as it is, if you need to replace the cable or remove the pulley, remove the bolt from the pulley. Be sure to lift the snowblower when it is free to move (not covered in ice, ...) and not covered with snow.
	Limit switch broken	Use shackle as it is, if you need to replace the cable or remove the pulley, remove the bolt from the pulley. See the troubleshooting section for this problem on the next page.
	Cable wound up in reverse, therefore the limit switch did not stop the winch when lifting procedure was complete.	Use shackle as it is, if you need to replace the cable or remove the pulley, remove the bolt from the pulley. See the troubleshooting section for this problem on the next page.

TROUBLESHOOTING

* Please refer to parts breakdown section in subframe manual for parts identification.

HOW TO KNOW	POINTS TO CHECK
Poor connections.	Recheck wiring with the owner's manual
HI/LOW voltage tester does not work.	Connect it on battery posts (+ and -) of a functional battery. If there is no light, the tester is damaged.
The control switch inoperative.	Test both connectors with HI/LOW voltage tester. If light comes ON or the relay is clicking in both positions (UP & DOWN), the control switch is operative.
Relay is damaged	If there is voltage on battery wire posts 1 & 2 on the relay and no voltage on posts 3 & 4 when control switch is activated and relay is clicking in both directions, the relay is defective. (see relay assembly section in owner's manual for relay post identification). Check connections with HI/LOW voltage tester.
Winch is damaged	The ultimate test is to connect the winch directly to the battery and reverse the wires to test both directions. If the winch doesn't work, it is damaged.
The limit switch is damaged.	When the limit switch is pushed or stuck inside, the winch can't raise the accessory, only lower it. If not working properly replace it.
The breaker is damaged.	Place clip of the HI / LOW voltage tester on negative (-) post of the battery. Check the voltage with the tip of the tester on both terminals of the breaker. If voltage only on 1 terminal replace the breaker. (sometimes it could take a few minutes for the breaker to automatically reset itself)

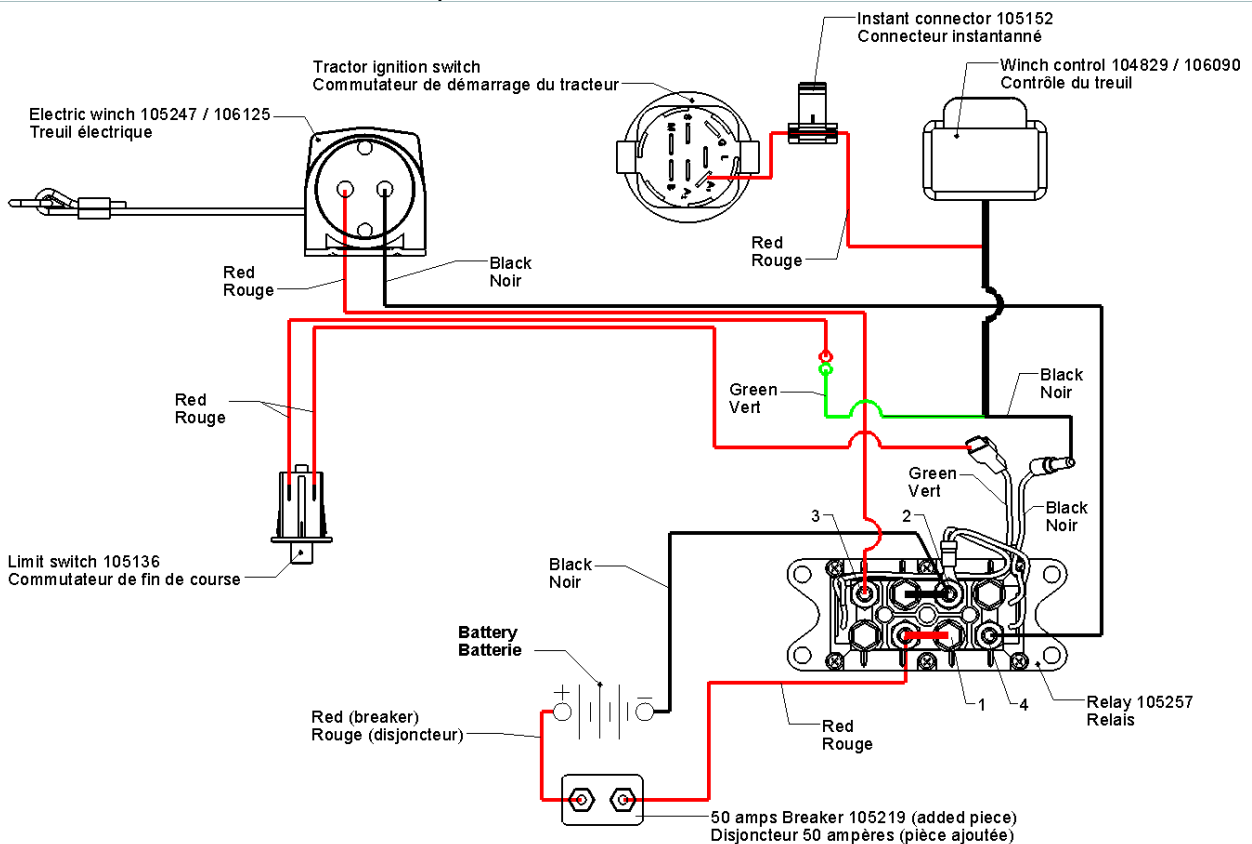

TORQUE SPECIFICATION TABLE

GENERAL TORQUE SPECIFICATION TABLE USE THE FOLLOWING TORQUES WHEN SPECIAL TORQUES ARE NOT GIVEN

NOTE: These values apply to fasteners as received from supplier, dry or when lubricated with normal oil. They do not apply if special graphited or moly disulphide greases or other extreme pressure lubricants are used. This applies to both UNF and UNC threads.

* Thick nuts must be used with grade 8 bolts

SEE Grade No.		2				5				8 *			
BOLT HEAD IDENTIFICATION MARKS AS PER GRADE NOTE MANUFACTURING MARKS WILL VARY		TORQUE				TORQUE				TORQUE			
BOLT SIZE		FOOT POUNDS		NEW TON-METERS		FOOT POUNDS		NEW TON-METERS		FOOT POUNDS		NEW TON-METERS	
Inches	Millimetre	Min.	Max.	Min.	Max.	Min.	Max.	Min.	Max.	Min.	Max.	Min.	Max.
1/4"	6.35	5	6	6.8	8.13	9	11	12.2	14.9	12	15	16.3	30.3
5/16"	7.94	10	12	13.6	16.3	17	20.5	23.1	27.8	24	29	32.5	39.3
3/8"	9.53	20	23	27.1	31.2	35	42	47.5	57	45	54	61	73.2
7/16"	11.11	30	35	40.7	47.4	54	64	73.2	86.8	70	84	94.9	113.9
1/2"	12.7	45	52	61	70.5	80	96	108.5	130.2	110	132	149.2	179
9/16"	14.29	65	75	88.1	101.6	110	132	149.2	179	160	192	217	260.4
5/8"	15.88	95	105	128.7	142.3	150	180	203.4	244.1	220	264	298.3	358
3/4"	19.05	150	185	203.3	250.7	270	324	366.1	439.3	380	456	515.3	618.3
7/8"	22.23	160	200	216.8	271	400	480	542.4	650.9	600	720	813.6	976.3
1"	25.4	250	300	338.8	406.5	580	696	786.5	943.8	900	1080	1220.4	1464.5

METRIC BOLT TORQUE SPECIFICATIONS							
		COARSE THREAD			FINE THREAD		
Size Screw	Grade No.	Pitch (mm)	Foot Pounds	Newton-Meters	Pitch (mm)	Foot Pounds	Newton-Meters
M6	4T	1.00	3.6 - 5.8	4.9 - 7.9	-	-	-
	7T		5.8 - 9.4	7.9 - 12.7		-	-
	8T		7.2 - 10	9.8 - 13.6		-	-
M8	4T	1.25	7.2 - 14	9.8 - 19	1.00	12 - 17	16.3 - 23
	7T		17 - 22	23 - 29.8		19 - 27	25.7 - 36.6
	8T		20 - 26	27.1 - 35.2		22 - 31	29.8 - 42
M10	4T	1.50	20 - 25	27.1 - 33.9	1.25	20 - 29	27.1 - 39.3
	7T		34 - 40	46.1 - 54.2		35 - 47	47.4 - 63.7
	8T		38 - 46	51.5 - 62.3		40 - 52	54.2 - 70.5
M12	4T	1.75	28 - 34	37.9 - 46.1	1.25	31 - 41	42 - 55.6
	7T		51 - 59	69.1 - 79.9		56 - 68	75.9 - 92.1
	8T		57 - 66	77.2 - 89.4		62 - 75	84 - 101.6
M14	4T	2.00	49 - 56	66.4 - 75.9	1.50	52 - 64	70.5 - 86.7
	7T		81 - 93	109.8 - 126		90 - 106	122 - 143.6
	8T		96 - 109	130.1 - 147.7		107 - 124	145 - 168
M16	4T	2.00	67 - 77	90.8 - 104.3	1.50	69 - 83	93.5 - 112.5
	7T		116 - 130	157.2 - 176.2		120 - 138	162.6 - 187
	8T		129 - 145	174.8 - 196.5		140 - 158	189.7 - 214.1
M18	4T	2.00	88 - 100	119.2 - 136	1.50	100 - 117	136 - 158.5
	7T		150 - 168	203.3 - 227.6		177 - 199	239.8 - 269.6
	8T		175 - 194	237.1 - 262.9		202 - 231	273.7 - 313
M20	4T	2.50	108 - 130	146.3 - 176.2	1.50	132 - 150	178.9 - 203.3
	7T		186 - 205	252 - 277.8		206 - 242	279.1 - 327.9
	8T		213 - 249	288.6 - 337.4		246 - 289	333.3 - 391.6

PARTS BREAKDOWN CHUTE WITH ROTATION SYSTEM

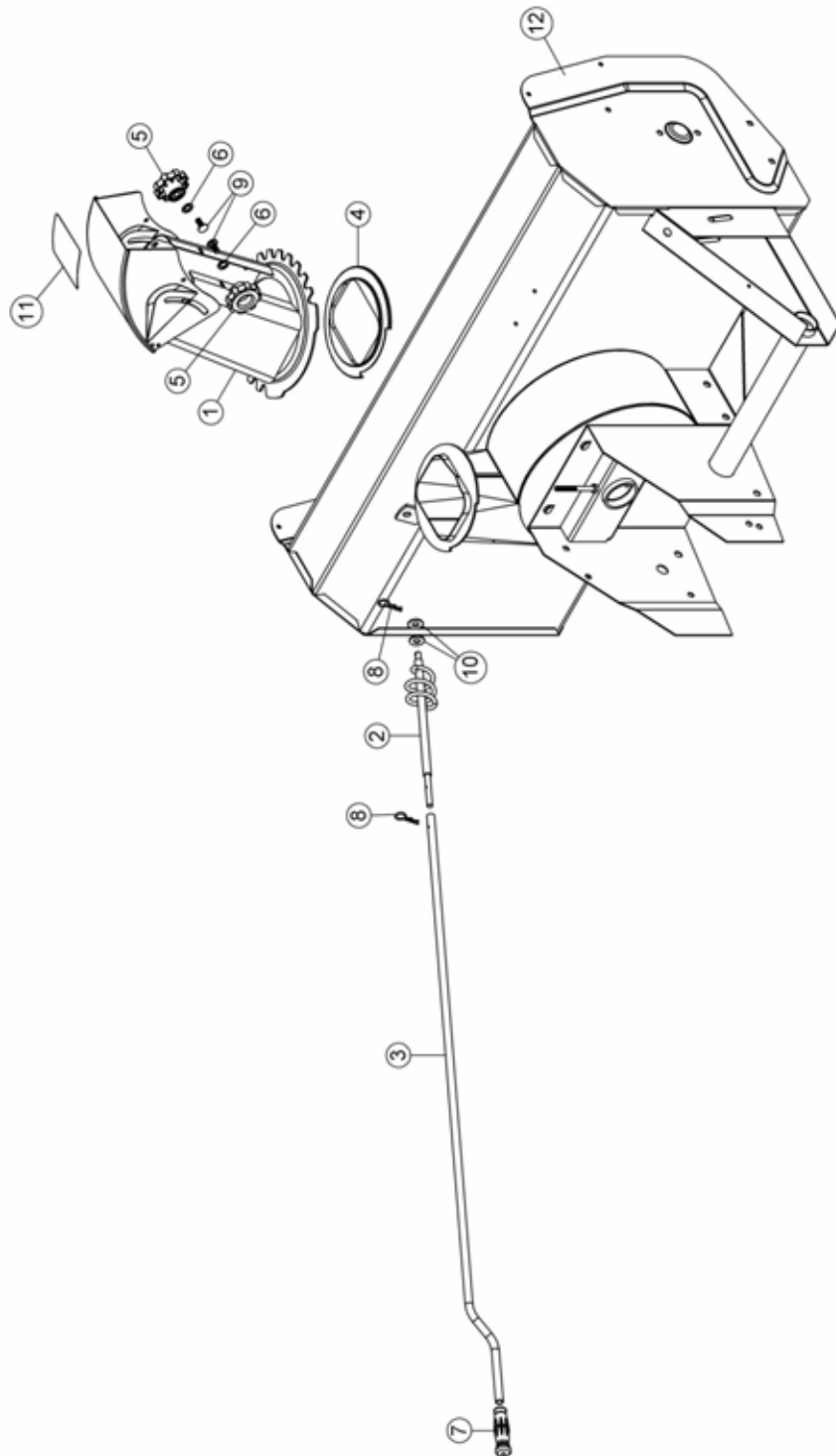

PARTS LIST

CHUTE WITH ROTATION SYSTEM

Ref. Réf.	English description	Description française	Qty. Qté.	Part # Pièce #
1	Chute	Goulotte	1	102748
2	Rotation worm	Spirale de rotation	1	102695
3	Handle	Manivelle	1	102061
4	Rotation ring	Coussinet de rotation	1	102756
5	Knob	Bouton	2	102020
6	Nylon flat washer 7/16"	Rondelle plate de nylon 7/16"	2	102011
7	Handgrip	Poignée	1	102062
8	Hair pin 2.5mm	Goupille à ressort 2.5mm	2	102013
9	Carriage bolt 5/16" n.c. x 3/4"	Boulon à carrosserie 5/16" n.c. x 3/4"	2	O/L
10	Flat washer 7/16" hole	Rondelle plate 7/16" trou	2	O/L
11	Danger decal chute	Décalque danger goulotte	1	105127
12	Frame	Châssis	1	REF

O/L = Obtain Locally

PARTS BREAKDOWN SNOWBLOWER 700465-3

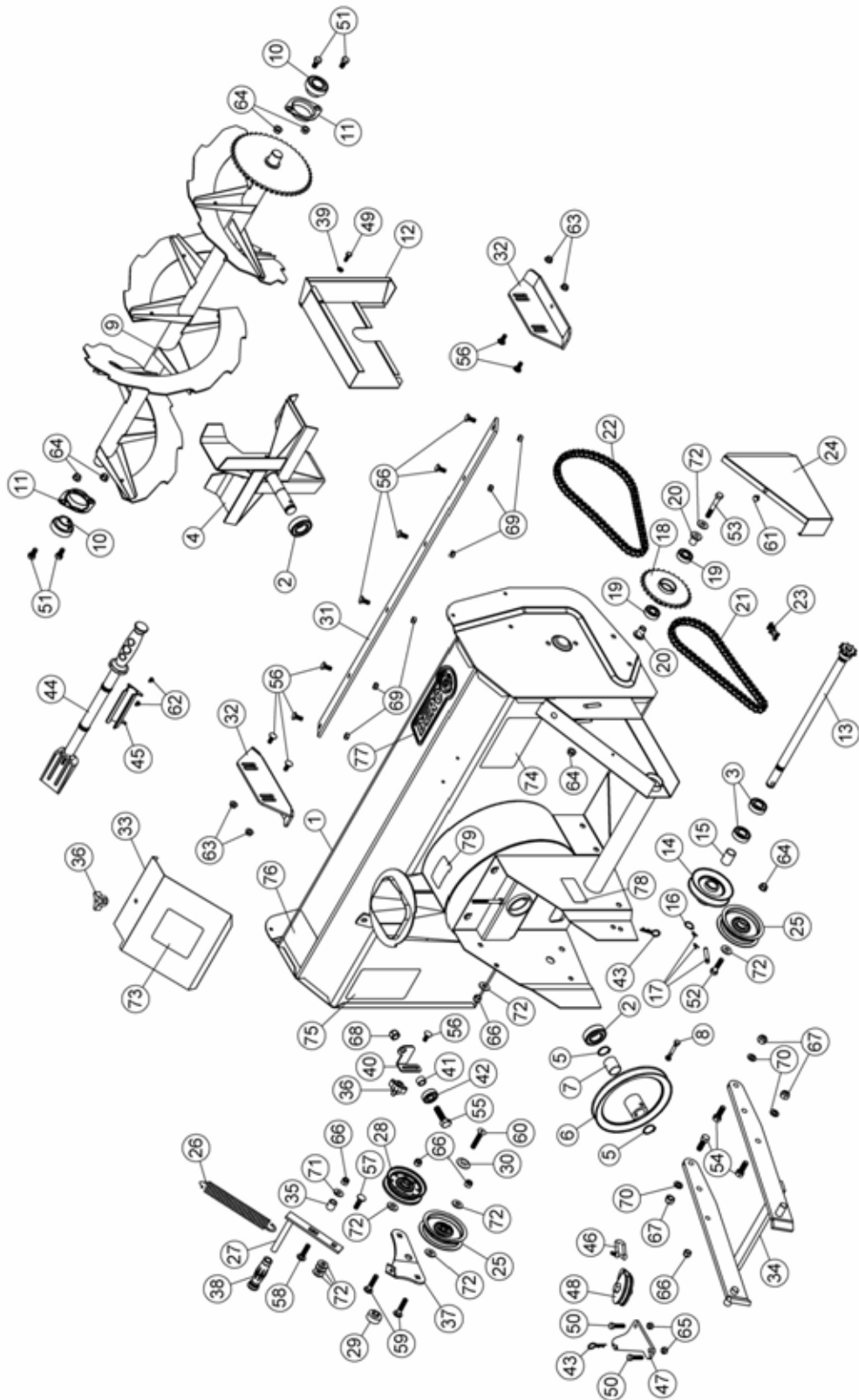

PARTS LIST SNOWBLOWER 700465-3

Ref. Réf.	English description	Description française	Qty. Qté.	Part # Pièce #
1	Frame	Châssis	1	104808
2	Bearing	Roulement à billes	2	102757
3	Bearing	Roulement à billes	2	102758
4	Fan	Éventail	1	102743
5	Retaining ring	Bague de retenue	2	102760
6	Main drive pulley inc. 102784	Poulie d'entraîn. princ. inc. 102784	1	102691
7	Oil lite bushing	Coussinet imprégné d'huile	1	102784
8	Shear bolt /N.I.L.N.T. pkg-10	Boulon de séc. /É.G.N.M. pqt-10	1	102744
9	Auger 40"	Vis 40"	1	102000
10	Bearing with set screw	Roulement à billes avec vis à pression	2	102755
11	Flangette	Flangette	2	102680
12	Chain guard	Garde-chaîne	1	102698
13	Drive shaft	Arbre de commande	1	102696
14	Auger drive pulley inc. 102783	Poulie d'entraîn. de la vis inc. 102783	1	102690
15	Oil-lite bushing	Coussinet imprégné d'huile	1	102783
16	Retaining ring	Bague de retenue	1	102761
17	Nylon shear pin w/2 clips pkg-10	Goupille de sécurité nylon a/2 clips pqt-10	1	102747
18	Double sprocket inc. 102759 & 102683	Pignon double inc. 102759 & 102683	1	102684
19	Bearing	Roulement à billes	2	102759
20	Flange sleeve	Douille à bride	2	102683
21	Roller chain #40 x 54 /w connecting link	Chaîne #40 x 54 mailles /a maille d'accoup.	1	102767
22	Roller chain #40 x 64 /w connecting link	Chaîne #40 x 64 mailles /a maille d'accoup.	1	102768
23	Connecting Link #40	Maille d'accouplement #40	1	102040
24	Chain guard	Garde-chaîne	1	102745
25	Flat pulley	Poulie plate	2	102765
26	Spring	Ressort	1	102861
27	Tension arm	Bras de tension	1	103026
28	Idler	Poulie	1	103044
29	Flange washer	Rondelle à bride	1	103025
30	Special washer	Rondelle plate spécial	1	103042

O/L = Obtain Locally

PARTS LIST SNOWBLOWER 700465-3

Ref. Réf.	English description	Description française	Qty. Qté.	Part # Pièce #
31	Cutting edge 40"	Racloir 40"	1	102047
32	Skid shoe	Patin	2	103188
33	Belt guard	Garde courroie	1	104811
34	Male Hitch	Attache mâle	1	104809
35	Sleeve	Douille	1	103028
36	Knob	Bouton	2	103027
37	Tension lever	Levier de tension	1	104810
38	Handgrip	Poignée	1	102062
39	Spring Washer	Rondelle à ressort	1	104352
40	Bracket	Fixation	1	104737
41	Bushing	Coussinet	1	102225
42	Bearing	Roulement à billes	1	104624
43	Hair pin 2.5mm	Goupille à ressort 2.5mm	2	102013
44	Chute shovel	Pelle à goulotte	1	105700
45	Chute shovel support	Support de pelle à goulotte	1	105701
46	Shackle	Clévis	1	107153
47	Hitch plate	Plaque d'attache	1	107154
48	Pulley assembly	Poulie assemblée	1	107157
49	Hex. bolt 1/4" n.c. x 3/4"	Boulon hex. 1/4" n.c. x 3/4"	1	O/L
50	Hex. bolt 5/16" n.c. x 1 1/4" GR8	Boulon hex. 5/16" n.c. x 1 1/4" GR8	2	O/L
51	Hex. bolt 3/8" n.c. x 3/4"	Boulon hex. 3/8" n.c. x 3/4"	4	O/L
52	Hex. bolt 3/8" n.c. x 1 1/2"	Boulon hex. 3/8" n.c. x 1 1/2"	1	O/L
53	Hex. bolt 3/8" n.c. x 2 1/2"	Boulon hex 3/8" n.c. x 2 1/2"	1	O/L
54	Hex. bolt 7/16" n.c. x 1 1/4"	Boulon hex. 7/16" n.c. x 1 1/4"	3	O/L
55	Hex. bolt 1/2" n.c. x 1 3/4"	Boulon hex. 1/2" n.c. x 1 3/4"	1	O/L
56	Carriage bolt 5/16" n.c. x 3/4"	Boulon à carrosserie 5/16" n.c. x 3/4"	11	O/L
57	Carriage bolt 3/8" n.c. x 1 1/4"	Boulon à carrosserie 3/8" n.c. x 1 1/4"	1	O/L
58	Carriage bolt 3/8" n.c. x 1-1/2"	Boulon à carrosserie 3/8" n.c. x 1 1/2"	1	O/L
59	Carriage bolt 3/8" n.c. x 1 3/4"	Boulon à carrosserie 3/8" n.c. x 1 3/4"	2	O/L
60	Hex socket f.h. cap screw 3/8" n.c. x 2"	Vis a pression hex. t.p. 3/8" n.c. x 2"	1	O/L

PARTS LIST SNOWBLOWER 700465-3

Ref. Réf.	English description	Description française	Qty. Qté.	Part # Pièce #
61	Tapping screw 1/4"-14 x 1/2"	Vis taraudeuse 1/4"-14 x 1/2"	1	O/L
62	Socket Head Cap Screw M5 x 0.80 x 10	Vis six PC tête ronde M5 x 0.80 x 10	2	O/L
63	Flange nut 5/16" n.c.	Écrou à bride 5/16" n.c.	4	O/L
64	Flange nut 3/8" n.c.	Écrou à bride 3/8" n.c.	6	O/L
65	Nylon Insert lock Nut 5/16" n.c. GR5	Écrou à garniture de nylon 5/16" n.c. GR5	2	O/L
66	Nylon insert lock nut 3/8" n.c.	Écrou à garniture de nylon 3/8" n.c.	5	O/L
67	Nylon insert lock nut 7/16" n.c.	Écrou à garniture de nylon 7/16" n.c.	3	O/L
68	Nylon Insert lock Nut 1/2" n.c.	Écrou à garniture de nylon 1/2" n.c.	1	O/L
69	Stover lock nut 5/16" n.c.	Écrou de blocage 5/16" n.c.	6	O/L
70	Lock washer 7/16"	Rondelle de blocage 7/16"	3	O/L
71	Flat washer 3/8" hole	Rondelle plate 3/8" trou	1	O/L
72	Flat washer 7/16" hole	Rondelle plate 7/16" trou	9	O/L
73	Decal danger belts	Decalque danger courroies	1	105128
74	Decal warning safety	Decalque avertissement sécurité	1	105131
75	Decal read instructions	Decalque lire instructions	1	105130
76	Decal danger auger	Decalque danger vis	1	105126
77	Berco decal	Décalque Berco	1	102471
78	Serial number	Numéro de série	1	REF
79	Made in Canada decal	Décalque Fabriqué au Canada	1	REF

O/L = Obtain Locally

OPTIONS & ATTACHMENTS

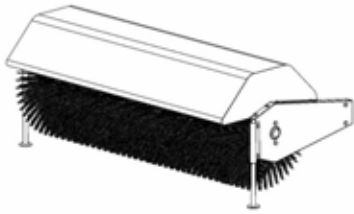

ROTARY BROOM
#700380 with nylon brush
/#700381 with polypropylene brush.

Fits on same subframe as snowblower or utility blade.
Requires an adaptor.

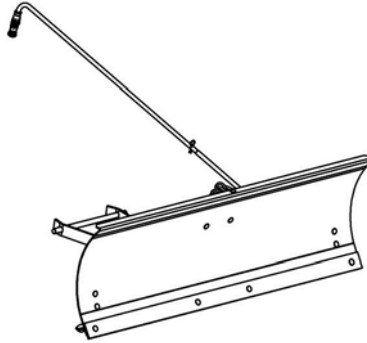

SNOWBLADE #700463
Mounts on the same subframe as the snowblower & rotary broom.

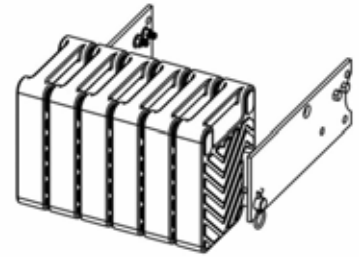

COUNTERWEIGHT
Model # as per tractor.
Required for safety and traction.
Counter-balances weight of attachment.

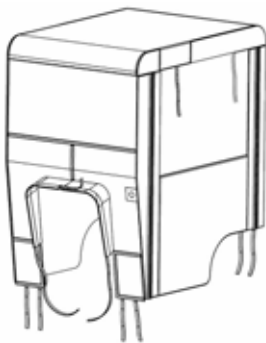

TRACTOR WINTER CAB
#700271
#700423
Universal type fits on a wide variety of lawn and garden tractors.

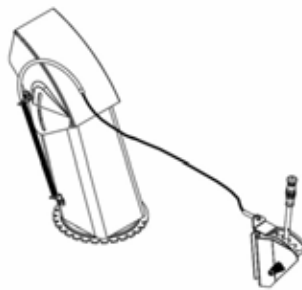

DEFLECTOR ADJUSTMENT KIT
#700239

Adjusts height at which snow is thrown from the driver's seat.

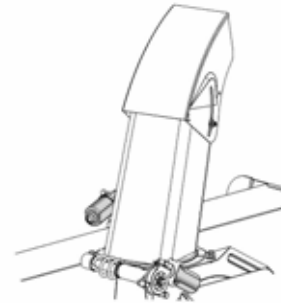

ELECTRIC CHUTE & DEFLECTOR
#700522
ELECTRIC DEFLECTOR KIT #700526
Allows to turn chute and adjust deflector electrically from driver's seat.



SNOW DRIFT CUTTER
#700260 for Compact & Northeast snowblowers.
Facilitates and increases snow intake.
Pkg. of 2

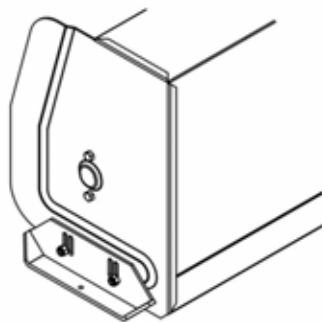

HEAVY DUTY SKID SHOES
#700243

For gravel driveways.
Pkg. of 2

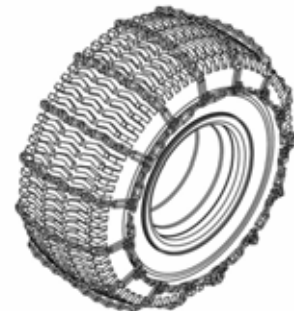

TIRE CHAINS

Two link spacing. Required for traction and safety.
Pkg. of 2

NOTES

NOTES



***WHEN PERFORMANCE
& DEPENDABILITY
ARE NON NEGOTIABLE!***

**Bercomac Limitée
92, Fortin North, Adstock, Quebec, Canada, G0N 1S0**

WWW.BERCOMAC.COM

PRINTED IN CANADA

(ORIGINAL NOTICE)