



OWNER'S MANUAL

Model Number

700469 Subframe with Winch

700470 Compact Drive Mechanism

700471 Northeast Drive Mechanism



BERCO

Subframe with Electric Lift & Drive Mechanism

for

JOHN DEERE TRACTORS LA SERIES

- * ASSEMBLY
- * OPERATION

- * REPAIR PARTS
- * MAINTENANCE

CAUTION:
READ & FOLLOW ALL SAFETY RULES & INSTRUCTIONS BEFORE
OPERATING YOUR EQUIPMENT



LIMITED WARRANTY

Conditions and Products Covered:

BERCOMAC guarantees any part of the product or accessory manufactured by BERCOMAC and found in the reasonable judgment of BERCOMAC to be defective in material and or workmanship will be repaired or replaced by an authorized dealer without charge up to our maximum labor rates and pre-established times. For replacement parts only standard ground freight services are covered. This warranty extends to the original retail purchaser only and is not transferable to any subsequent purchasers.

Warranty Period

(from date of the original retail purchase):

- Residential use: 1 year
- Commercial or rental use: 90 days

Exceptions Noted Below; the following items are guaranteed by the original manufacturer and have their own warranty, conditions and limited time:

- Tire Chains: 90 days
- Engines (installed in factory on BERCO equipment): 2 years
- Engines (sold separately): Validate with the dealer. Please refer to the engine manufacturer's warranty statement included with the unit. BERCOMAC is not authorized to handle warranty adjustments on engines.

Items and Conditions NOT Covered:

This warranty does not cover the following:

- Pick-up or delivery charges or in-home services fees.
- Any damage or deterioration of the unit, parts and or finish of these due to normal use, wear and tear, or exposure.
- Cost of regular use or maintenance service or parts, such as gas, oil, lubricants, tune-up parts, and adjustments.
- Any part or accessory which has been altered, modified, misused, neglected, accidentally damaged or not properly installed, maintained, stored or repaired not in accordance with the instructions in the owner's manual.
- Repair due to normal wear and or any wear items such as shear pins, bolts, belts, etc.
- Expedited freight fee services for replacement parts.
- Shear bolts and shear pins are to be considered as a preventive measure not as an assured protection, any damages resulting from the lack of shear bolts breakage are not covered.

NOTE: All warranty work must be performed by an authorized dealer using original (manufacturer) replacement parts.

NOTE: Bercomac reserves the right to change or improve the design of any part or accessory without assuming any obligation to modify any product previously manufactured.

Instructions for Obtaining Warranty Services:

Contact dealer where equipment was purchased or any other BERCOMAC service dealer to arrange service at their dealership. To locate a dealer convenient to you, access our website at www.bercomac.com. Don't forget to bring the product and your proof of purchase (sales receipt) to the BERCOMAC dealer.

Owner's Responsibilities:

BERCOMAC's defective equipment or part must be returned to an authorized dealer within the warranty period for repairs. In the event that defective merchandise must be returned to manufacturer for repairs, freight fees are prepaid and a written authorization from BERCOMAC must be obtained by dealer prior to the shipment. This warranty extends only to equipment operated under normal conditions. To validate a warranty claim, it is the user's responsibility to maintain and service the unit as specified in the owner's manual or to have the unit serviced at their dealer at their expense.

General Conditions:

The sole liability of BERCOMAC with respect to this warranty shall be strictly and exclusively repair and replacement as mentioned herein. BERCOMAC shall not have any liability for any other costs, loss or damage, including but not limited to, any incidental or consequential loss or damage.

In particular, without being limited to, BERCOMAC shall have no liability or responsibility for:

- Travel time, overtime, after hours time or other extraordinary repair charges or relating to repairs and or replacements outside of normal business hours.
- Rental of like or similar replacement equipment during the period of any, repair or replacement work.
- Any communicating or travel charges.
- Loss or damage to person or property other than that covered by the terms of this warranty.
- Any claims for lost revenue, lost profit or any similar costs as a result of damage or repair.
- Attorney's fees.

BERCOMAC's responsibility in respect to claims is limited to making the required repairs or replacement without charge up to our maximum labor rates and pre-established times and no claim of breach of warranty shall be cause for cancellation or rescission of the contract of sale of any product or accessory.

This warranty gives you specific legal rights. You may also have other rights, which vary from state to state.

TABLE OF CONTENTS

	PAGE
INTRODUCTION	2
SAFETY PRECAUTIONS	3
SAFETY DECALS	5
ASSEMBLY	
Tools Required	6
Step 1: Subframe Installation	6
Step 2: Installation the Control Assembly	8
Step 3: Drive Mechanism Installation	11
OPERATION & MAINTENANCE	
Controls	14
Maintenance	14
Belt Replacement	14
Verify Tire Pressure	14
DISMOUNTING & STORAGE	
Dismounting	15
Storage	15
PARTS BREAKDOWN AND PARTS LIST	
Compact Drive Mechanism 700470	16
Northeast Drive Mechanism 700471	18
Subframe 700469	20
TORQUE SPECIFICATION TABLE	23
ATTACHMENTS	24

INTRODUCTION

TO THE PURCHASER

This new accessory was carefully designed to give years of dependable service. This manual has been provided to assist in the safe operation and servicing of your attachment.

NOTE: All photographs and illustrations in the manual may not necessarily depict the actual models or attachment, but are intended for reference only and are based on the latest product information available at the time of publication.

Familiarize yourself fully with the safety recommendations and operating procedures before putting the machine to use. Carefully read, understand and follow these recommendations and insist that they be followed by those who will use this attachment.



THIS SAFETY ALERT SYMBOL IDENTIFIES AN IMPORTANT SAFETY MESSAGE IN THIS MANUAL THAT HELPS YOU AND OTHERS AVOID PERSONAL INJURY OR EVEN DEATH. DANGER, WARNING, AND CAUTION ARE SIGNAL WORDS USED TO IDENTIFY THE LEVEL OF HAZARD. HOWEVER, REGARDLESS OF THE HAZARD, BE EXTREMELY CAREFUL.

DANGER: Signals an extreme hazard that will cause serious injury or death if recommended precautions are not followed.

WARNING: Signals a hazard that may cause serious injury or death if the recommended precautions are not followed.

CAUTION: Signals a hazard that may cause minor or moderate injury if the recommended precautions are not followed.

Record your attachment serial number and purchase date in the section reserved below (there is no serial number on the subframe). Your dealer requires this information to give you prompt, efficient service when ordering replacement parts. Use only genuine parts when replacements are required.

If warranty repairs are required please present this registration booklet and original sales invoice to your selling dealer for warranty service.

**This manual should be kept for future reference.
Please check if you have received all the parts for your kit with the list of the bag and the list of the box.**

SERIAL NUMBER : (IF APPLICABLE)	
MODEL NUMBER:	
PURCHASE DATE :	



SAFETY PRECAUTIONS



Careful operation is your best insurance against an accident. Read this section carefully before operating the vehicle and accessory. This accessory is capable of amputating hands and feet and throwing objects. Failure to observe the following safety instructions could result in serious injury. All operators, no matter how experienced they may be, should read this and other manuals related to the vehicle and accessory before operating. It is the owner's legal obligation to instruct all operators in safe operation of the accessory.

GLOSSARY:

In this manual, right and left sides are determined by sitting on the seat of the vehicle facing forward.

In this manual, "accessories" means attachments (snowblower, rotary broom, blade etc.) that you install on the vehicle (lawn tractors, A.T.V. s etc).

TRAINING:



This symbol, "Safety Alert Symbol", is used throughout this manual and on the accessory's safety labels to warn of the possibility of serious injury. Please take special care in reading and understanding the safety precautions before operating the vehicle and accessory.

1. Read this owner's manual carefully. Be thoroughly familiar with the controls and proper use of the vehicle and accessory. Know how to stop the unit and disengage the controls quickly.
2. Never allow children to operate the vehicle nor the accessory. Never allow adults to operate the vehicle nor the accessory without proper instructions.
3. No one should operate the vehicle nor the accessory while intoxicated or while taking medication that impairs the senses or reactions.
4. Keep the area of operation clear of all people, particularly small children and pets.

PREPARATION:

1. Thoroughly inspect the area where the accessory is to be used and remove door mats, all foreign objects and the like.
2. For motorized accessories, disengage all clutches and shift into neutral before starting engine.
3. Do not operate the accessory without wearing adequate winter outer garments. Avoid loose fitting clothing that can get caught in moving parts. Wear footwear that will improve footing on slippery surfaces.

4. Handle fuel with care, it is highly flammable.

- a) Use approved fuel container.
 - b) Never add fuel to a running engine or hot engine.
 - c) Fill fuel tank outdoors with extreme care. Never fill fuel tank indoors.
 - d) Never fill containers inside a vehicle, or on a truck or a trailer bed with a plastic liner. Always place containers on the ground, away from your vehicle, before filling.
 - e) When practical, remove gas-powered equipment from the truck or trailer and refuel it on the ground. If this is not possible, then refuel such equipment on a trailer with a portable container, rather than from a gasoline dispenser nozzle.
 - f) Keep the nozzle in contact with the rim of the fuel tank or container opening at all times, until refueling is complete. Do not use a nozzle lock-open device.
 - g) Replace fuel cap securely and wipe up spilled fuel.
 - h) If fuel is spilled on clothing, change clothing immediately.
5. Never attempt to make any adjustments while the engine (motor) is running (except when specifically recommended by manufacturer).
 6. Let the vehicle and accessory adjust to outdoor temperatures before starting to clear snow.
 7. Never use an accessory without proper guards, plates, or other safety protective devices in place
 8. Always make sure to wear the appropriate safety equipment required (glasses, muffs, mask...) for each type of product. See operation section.
 9. Always make sure of having safe traction on the vehicle by using the recommended accessories (chains, A.T.V. tracks, counterweights...). See operation section.
 10. **Never modify the accessory or any part without the written consent from the manufacturer.**



SAFETY PRECAUTIONS



OPERATION:

1. Do not put hands or feet near, under or inside rotating parts.
2. Exercise extreme caution when operating on or crossing gravel drives, walks or roads. Stay alert for hidden hazards or traffic. Do not carry passengers.
3. After striking a foreign object, stop the engine (motor), disconnect the wire from the spark plug(s) and keep wire away to prevent accidental starting. Thoroughly inspect the accessory for any damage and repair damage before restarting and using the accessory.
4. If the unit should start to vibrate abnormally, stop the engine (motor) and check immediately for the cause. Vibration is generally a warning of trouble.
5. Take all possible precautions when leaving the vehicle unattended. Disengage the power take-off, lower the attachment, place the transmission into neutral, set the parking brake, stop the engine and remove the contact key.
6. Do not run the engine indoors, except when starting the engine and for transporting in or out of the building. Do not operate or let motor run in a storage area without ventilation because gas contains carbon monoxide which is odorless, colorless and can cause death.
7. Never clean across the face of slopes, go from top to bottom. Exercise extreme caution when using equipment on slopes. Do not attempt to clear a steep slope.
8. Never tolerate bystanders in the working zone. Never use an accessory in the direction of bystanders, it might throw gravel or debris that can hurt people or damage property.
9. Never operate the accessory at high transport speeds on slippery surfaces. Use care when backing up.
10. Do not carry passengers.
11. Disengage power to the accessory when it is transported or not in use.
12. Never operate the accessory without good visibility or light.

14. Keep the accessory away from heat sources or flames.

MAINTENANCE AND STORAGE

1. When cleaning, repairing or inspecting the vehicle and accessory, make certain that all moving parts have stopped. Disconnect wire from the spark plug(s) and keep wire away to prevent accidental starting.
2. Check all the bolts at frequent intervals to make sure that they are properly tightened.
3. Never store a motorized accessory with fuel in the fuel tank inside a building where ignition sources are present such as hot water and space heaters, clothes dryers, and the like. Allow the engine to cool before storing in any enclosure.
4. Always refer to the owner's manual when you store the accessory and vehicle for a prolonged or an unspecified length of time.
5. Maintain or replace safety and instruction labels, as necessary.
6. For winter accessories, (if applicable), let the engine run for a few minutes after clean snow in order to prevent the rotary parts from freezing.
7. Inspect the vehicle's and accessory's air filter every day. Clean it or replace it as necessary. Change the oil more often when working in dusty conditions. See the vehicle's and accessory's owner's manual.



**THIS SYMBOL MEANS
DANGER !
BECOME ALERT !
YOUR SAFETY IS INVOLVED !**



SAFETY DECALS



REPLACE IF DECALS ARE DAMAGED
SEE PARTS BREAKDOWN FOR DECAL LOCATION

DECAL #105133



To avoid serious injuries:
Keep hands away from the hot surface.

ASSEMBLY

IMPORTANT: TORQUE ALL BOLTS ACCORDING TO TORQUE SPECIFICATION TABLE WHEN STATED: TIGHTEN FIRMLY.

THE WINCH KIT IS TO BE USED ONLY TO LIFT BERCO ACCESSORIES, ANY OTHER USE MAY CAUSE DAMAGE TO THE VEHICLE.

This subframe may be used to install different attachments (see attachments page). Once installed, it may remain permanently on your vehicle.

NOTE:It is not necessary to remove mower deck at this step.

STEP 1 **SUBFRAME INSTALLATION:**

Refer to parts breakdown section for parts identification.

Install the supports (item 3) on each side of the vehicle.		
Item #	Description	Action
1	Carriage bolt, 3/8 x 1" (qty 6)	Insert as shown.
2	Flat washer 1/2", (qty 7)	See
3	Support (qty 2)	Install on the bolts as shown
4	Flange nut 3/8", (qty 6)	Do not tighten now.
*If necessary, use the flat washers to keep the supports flat on the vehicle's frame.		

TOOLS REQUIRED:

- Wrenches: 5/16, 7/16, 9/16, 1/2, 10mm
- Ratchet
- Sockets: 9/16, 1/2
- Pliers
- Square head screwdriver: #2
- 1 wrench (for the nuts on the battery posts of the vehicle)

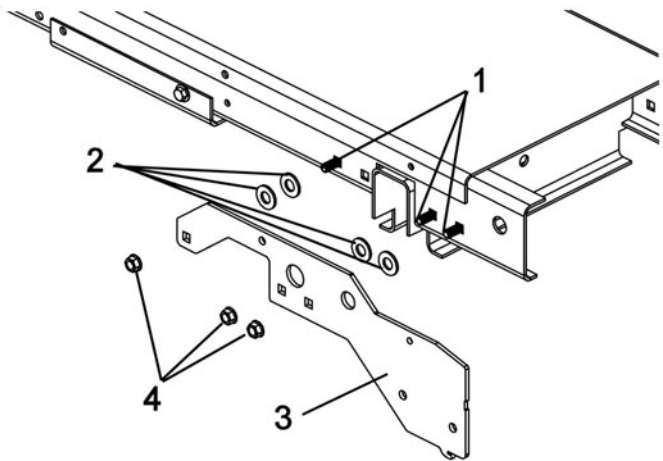

Install the supports

Install the female hitch (item 1).		
# Item	Description	Action
1	Female hitch	Install between the two supports.
2	Hex bolt 3/8 x 1" (qty 4)	Insert as shown.
3	Flange nut 3/8" (qty 4)	Tighten the all the nuts firmly.

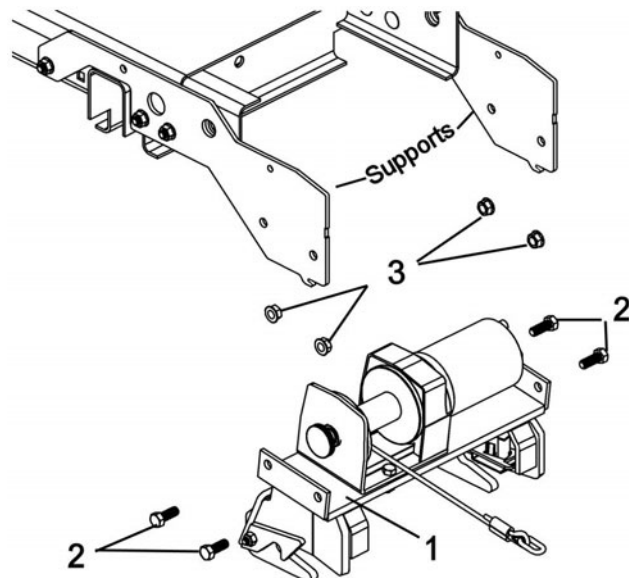

Install the female hitch between the two supports

ASSEMBLY

Install the spring (item 1)

# Item	Description	Action
1	Spring	Install the spring on the frame as shown.

NOTE: The latch must move freely.

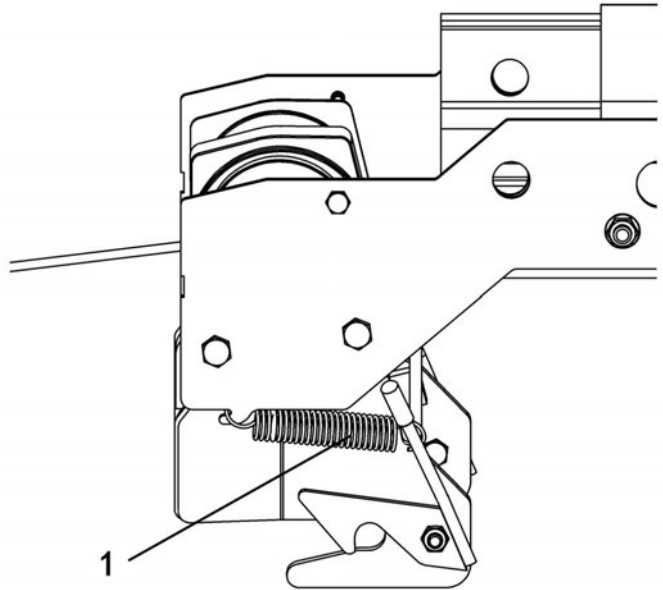

Install the spring as shown

Install the handle support (item 3) on the left side.

# Item	Description	Action
1	Tractor bolt	Remove if tractor has a cable for manual clutch.
2	Tractor bolts (qty 2)	Remove from tractor.
3	Handle support	Install as shown using the tractor bolts (items 1 & 2). Tighten firmly.
4	Square head set screw 5/16 x 1/2"	Insert in the hole of the handle.
5	Plastic grommet	Insert as shown.

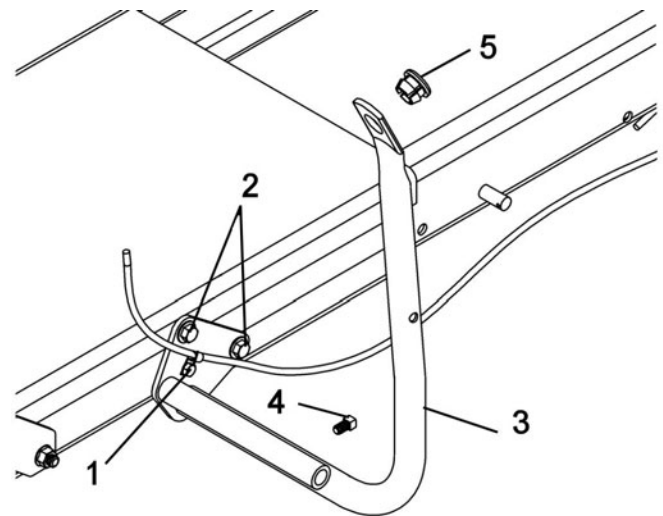
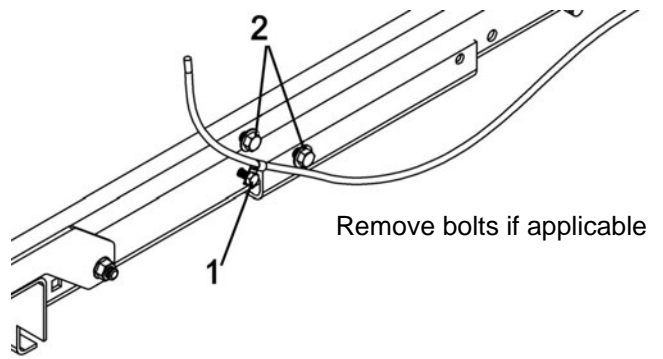

Install handle support

ASSEMBLY

Install the cab support (item 2) on the right side.

# Item	Description	Action
1	Tractor bolt	Remove to install cab support.
2	Cab support	Install as shown with tractor bolt.
3	Square head set screw 5/16 x 1/2"	Insert in the hole of the handle.

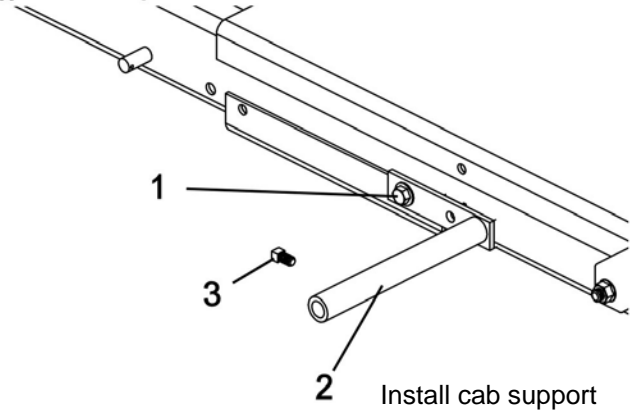

STEP 2: **INSTALLATION OF THE CONTROL ASSEMBLY**

Install the breaker (item 1).

# Item	Description	Action
1	Breaker	Install in an appropriate area.
2	Metal screw #12 x 3/4" (qty 4)	Secure breaker in place.
*3	Nylon tie wrap 8" (qty 4)	See *

* If necessary use the nylon tie wraps to secure the breaker in place.

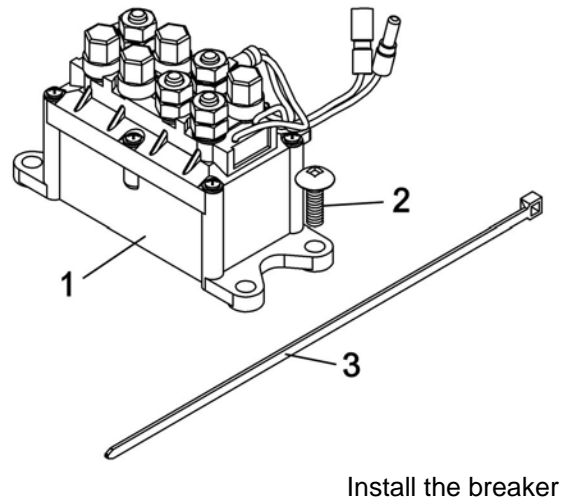

Install the control support (item 1)

# Item	Description	Action
1	Control support	Install in an appropriate area.
2	Metal screw #8 x 1/2" (qty 2)	Secure the support in place.
3	Control box for winch	Insert in the support.

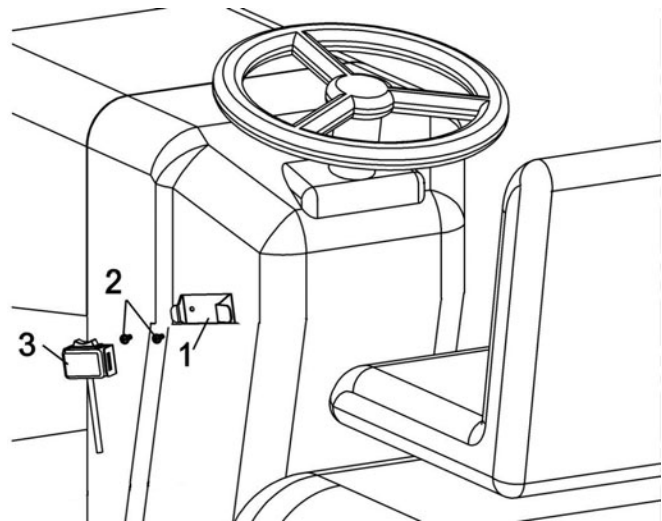

Install the support and control box for the winch

ASSEMBLY

CONNECTING THE WIRES

NOTE:The posts on the breaker are identified by numbers. (1-2-3-4).

Install the wires from the winch on the posts of the breaker.

Red wire (+) on post #3.
Black wire (-) on post #4.

Connect the green wire from the winch (snap mount switch) with the green wire from the breaker.

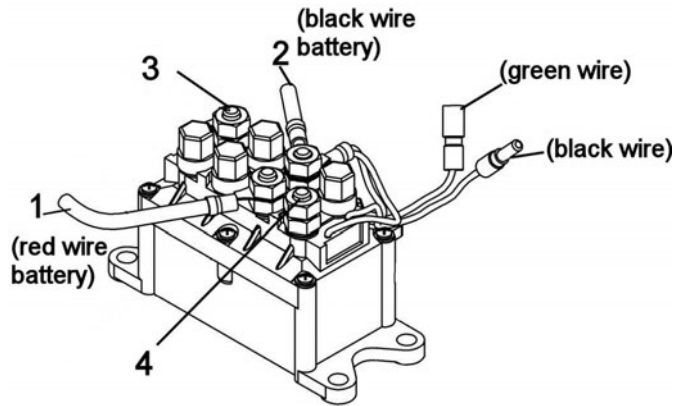

Connect the wires

IDENTIFY THE IGNITION WIRE:

Place the clip of the Hi / Low tester on the negative post (-) on the battery or a metal surface with out any paint.

Turn the ignition key to the position, accessory.

Insert the tip of the tester in a hole at the back of the starter (switch) make sure to touch the metal part of the wire.

If the tester's light turns on , turn the ignition key to the position, Off. The light must turn off. You have identified the ignition wire, if not repeat the operation on another wire.

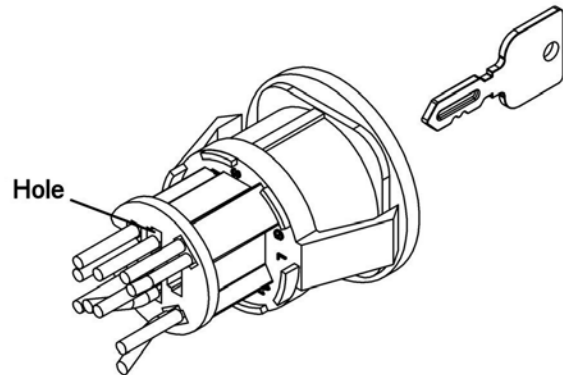

INSTALL THE CONTROL WIRE:

Join the ignition wire and the red wire from the control (item 1) with the instant connector (item 2).

Connect the black wire of the control to the black wire on the breaker.

Connect the green wire of the control with the green wire of the winch (snap mount switch).

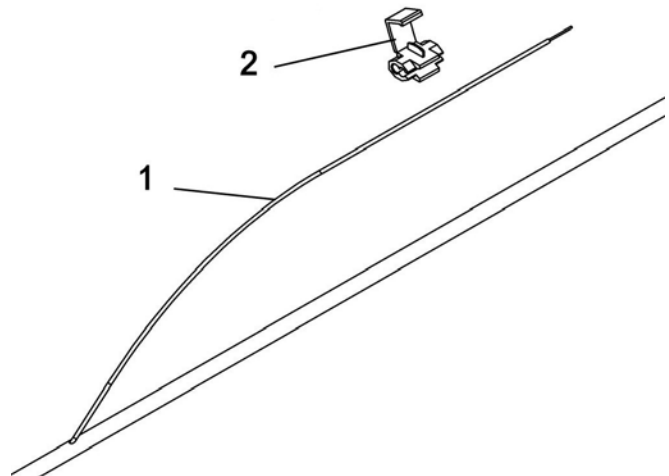

Connect the ignition wire

ASSEMBLY



CAUTION



FOR YOUR SECURITY:

Read and follow the safety precautions for the battery in the vehicle's manual.

CONNECT THE WIRES ON THE BATTERY:

Connect the wires from the breaker to the vehicle's battery.

The red wire (+) on the positive post of the battery (item 1).

The black wire (-) on the negative post of the battery (item 2).

Make sure to tighten the nuts on the posts.

TIE ALL THE WIRES:

NOTE: Make sure the wires from the control assembly do not interfere with anything on the tractor nor come into contact with any heating, electrical or removable elements of the tractor.

Tie the wires with four nylon tie wraps included in the kit.

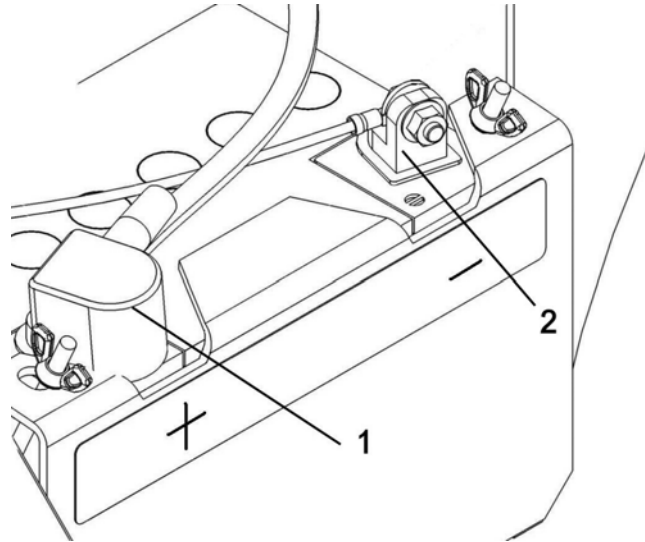

Connect the break wires to the battery

Install the heat shield (item 1).		
# Item	Description	Action
1	Heat shield	Install as shown.
2	Hex bolts 1/4 x 1/2" (qty 2)	Tighten firmly.

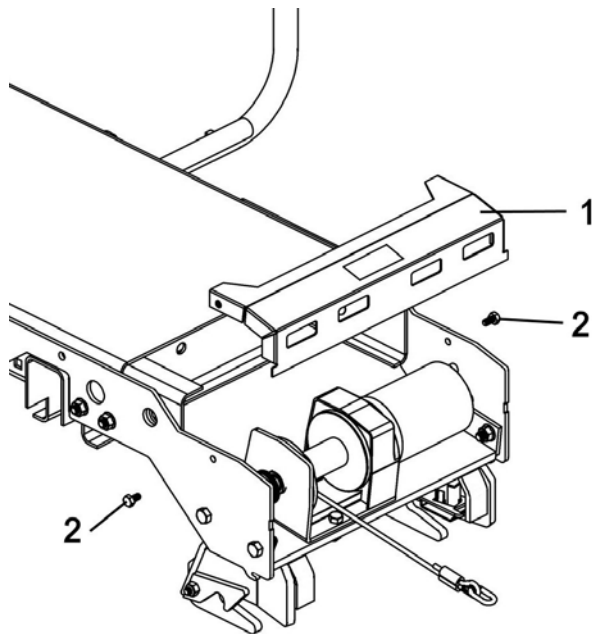

Install the heat shield

ASSEMBLY

STEP 3: DRIVE MECHANISM INSTALLATION:



WARNING



TO PREVENT INJURIES:

Stop the motor.
Apply parking brake.
Remove the ignition key.
Disconnect the wire from the spark plug(s) and keep away from spark plug(s) to prevent accidental starting.

NOTE: You must remove mower deck to install the drive mechanism.

Install the sleeve (item 1) on each side.

# Item	Description	Action
1	Sleeve (qty 2)	Install as shown.
2	Hex bolt 3/8 x 1 1/4" (qty 2)	Insert in the sleeve.
3	Flange nut 3/8" (qty 2)	Tighten firmly.



WARNING



TO PREVENT INJURIES:

It is the person who installs the drive mechanism responsibility to make sure that when the clutch is disengaged that all moving parts stop.

For more information, do not hesitate to contact the technical support.

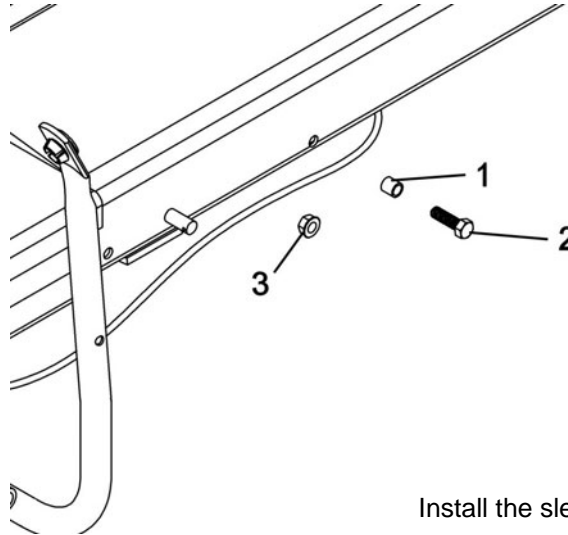

Install the drive mechanism (item 1).

# Item	Description	Action
1	The front end of drive mechanism	Hook on the pins.
2	Latch	Lift to open.
3	The back end of drive mechanism	Install on the sleeves. Release latch to lock into place.
4	Flat washer	See
5	Hair pin	See

*Reinstall the flat washers & hair pins that were on the pins from the mower deck supports.

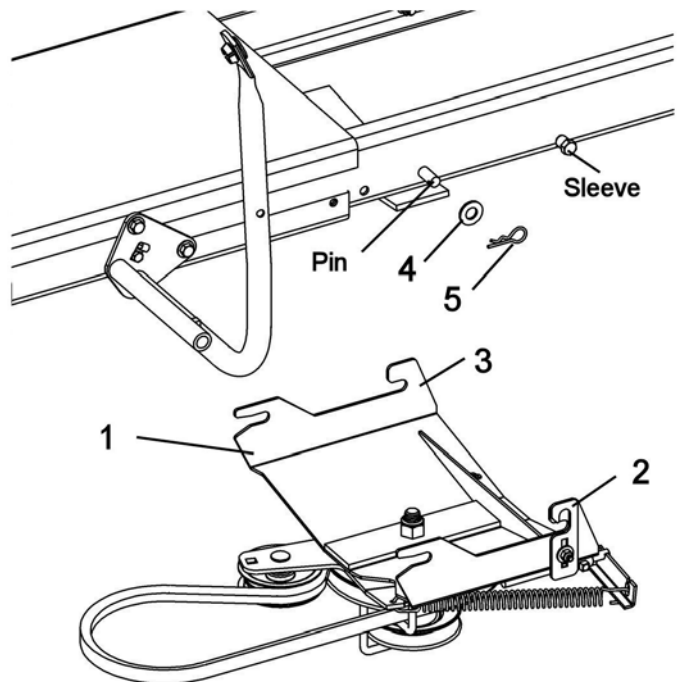

Install the drive mechanism

ASSEMBLY

For tractors with Electric Clutch:

Install the belt on the engine pulley of the vehicle.

Check the tension on the spring (item 1).

If necessary, adjust the tension by moving the adjustment rod (item 2) and tighten the set screw (item 3).

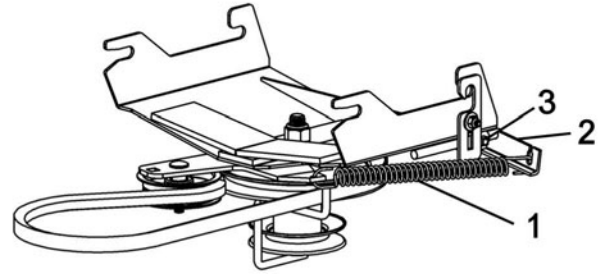

No modifications to be done

For tractors with Manual Clutch activated by a cable:

Install the tractor's manual clutch cable . * Remove the spring.		
# Item	Description	Action
1	Spring from the clutch cable	Install as shown in the hole on the idler arm.
2	Clutch cable	Insert in the slot on the adjustment rod.
3	Hair pin 2mm	Secure the cable.
4	Adjustment rod	Slide towards the back to apply enough tension on the spring.
5	Square head set screw 5/16 x 1/2"	Secure the adjustment rod.

Install the belt on the engine pulley of the vehicle.
Check the tension on the spring.
If necessary, adjust the tension by moving the adjustment rod and tighten the set screw.

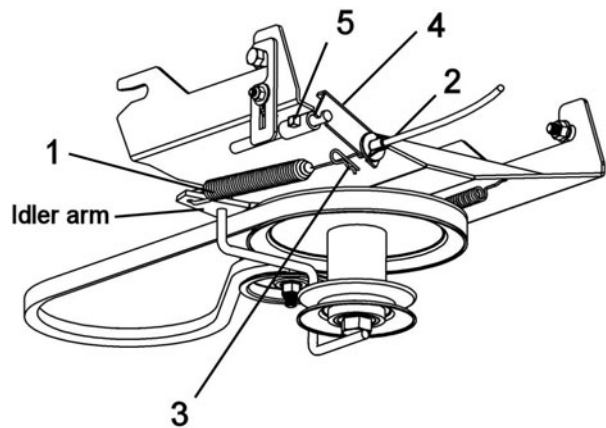

Install the manual clutch cable

ASSEMBLY

VERIFICATION OF THE BELT AND PULLEY ALIGNMENT:



WARNING



TO PREVENT INJURIES:
do this verification when the engine of the vehicle
is not running.

If applicable, you can remove or add a flat washer (item 1) on the tension pulley (item 2) for a better adjustment.

Engage and disengage the clutch a few times and make sure the belt does not touch the belt guide in any place when the drive mechanism is engaged.

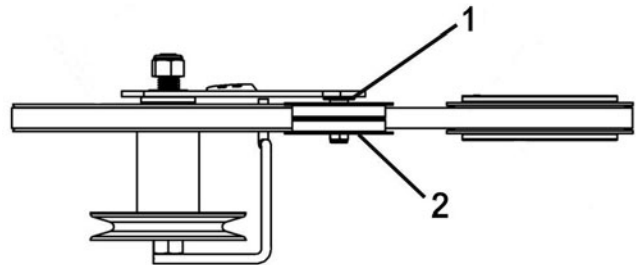

Adjust the pulleys



WARNING



TO PREVENT INJURIES:
It is the person who installs the drive mechanism
responsibility to make sure that when the clutch
is disengaged that all moving parts stop.

For more information, do not hesitate to contact
the technical support.

OPERATION & MAINTENANCE



CAUTION



Read the vehicle Owner's Manual carefully. Be thoroughly familiar with the controls & proper use of the attachment. Know how to stop the attachment quickly.

IMPORTANT:
THE WINCH KIT IS TO BE USED ONLY TO LIFT BERCO ACCESSORIES, ANY OTHER USE MAY CAUSE DAMAGE TO THE VEHICLE.

CONTROLS

IMPORTANT:
In order to avoid damage to the battery of the vehicle, always start the engine before using the winch.

THE SWITCH OF THE WINCH

Press on the switch of the winch to lift or lower the accessory to the ground.
There is a stopper that limits the lifting or the lowering of the accessory.

MAINTENANCE

- a) Check mounting bolts at frequent intervals for proper tightness to be sure equipment is in safe working condition.
- b) Apply oil at all pivot points.
- c) To prolong the life span of the winch, make sure the snap mount switch works well.

BELT REPLACEMENT

Belt for the accessories:
SEE ATTACHMENT OWNER'S MANUAL (SNOWBLOWER AND BROOM) FOR REPLACING INSTRUCTIONS.

Drive Mechanism Belt:

- a) Dismount the drive mechanism.
- b) Remove the bolt which retains the tension pulley.
- c) Replace the belt and re-install the tension pulley. Before tightening make sure the belt guide does not touch the belt at any time.
- d) Re-install the drive mechanism.
- e) Check the alignment of the belt that joins the drive mechanism to the engine pulley.

VERIFY TIRE PRESSURE:

Check and adjust tractor tire pressure as follows:

Front tires:	14-15 psi
Back tires:	7-8 psi

Tire pressure must be even on both sides of the tractor.

DISMOUNTING & STORAGE

DISMOUNTING

SEE ATTACHMENT OWNER'S MANUAL (SNOWBLOWER, BROOM AND BLADE) FOR DISMOUNTING INSTRUCTIONS.

- a) Dismount the attachment.
- b) Remove the rear counterweight when you remove the front attachment (if applicable).
- c) Remove the belt from the engine pulley.
- d) Dismount the drive mechanism by supporting it in hand and removing the two hair pins and the pins. Carefully lower to the ground. Remove the V-belt from engine pulley.

Manual clutch activated by cable:

Unhook cable shield by removing the hair pin. Unhook spring. Pull out drive mechanism from underneath tractor.

- e) You may leave the subframe on tractor all year long or remove it if preferred.
- f) Reinstall mower if needed.

STORAGE

- a) Clean and paint all parts from which paint has worn.
- b) Apply oil at all pivot points.
- c) Inspect and replace all defective parts before using again.

PARTS BREAKDOWN

COMPACT DRIVE MECHANISM 700470

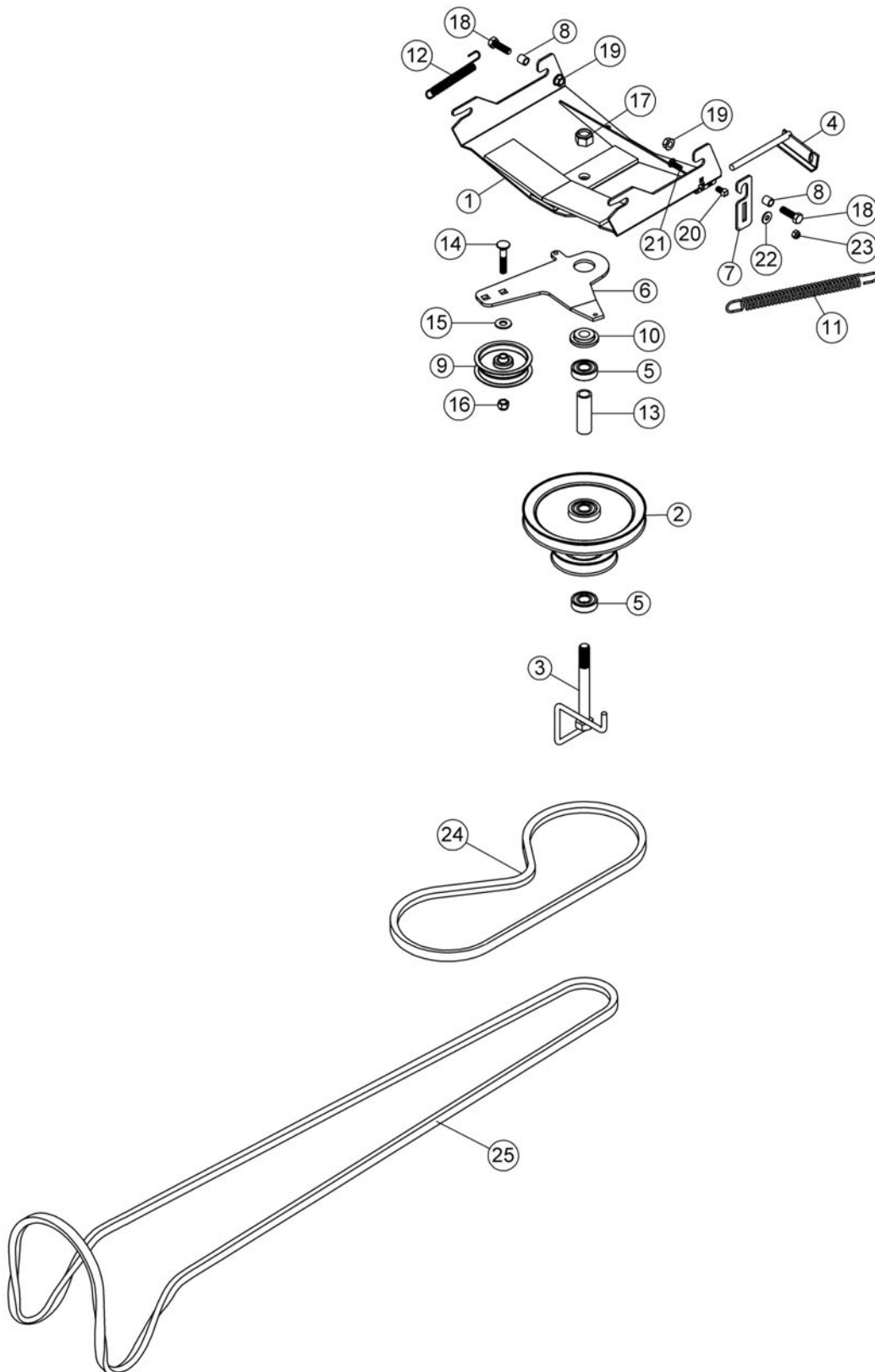

PARTS LIST

COMPACT DRIVE MECHANISM 700470

Ref. Réf.	English description	Description française	Qty. Qté.	Part # Pièce #
1	Drive frame	Châssis d'entraînement	1	104884
2	Double pulley inc. 102736 & 102782	Poulie double inc. 102736 & 102782	1	102692
3	Belt guide	Guide-courroie	1	104095
4	Adjustment rod	Tige d'ajustement	1	104841
5	Ball bearing	Roulement à billes	2	102736
6	Idler arm	Bras de tension	1	104883
7	Latch	Loquet	1	104885
8	Sleeve	Douille	2	104886
9	Flat pulley	Poulie plate	1	102839
10	Flange washer	Rondelle à bride	1	102969
11	Spring	Ressort	1	102304
12	Spring 1/2"	Ressort 1/2"	1	102003
13	Sleeve	Douille	1	102782
14	Carriage bolt 3/8" n.c. x 2"	Boulon à carrosserie 3/8" n.c. x 2"	1	O/L
15	Flat washer 7/16" hole	Rondelle plate 7/16" trou	1	O/L
16	Nylon insert lock nut 3/8" n.c.	Écrou à garniture de nylon 3/8" n.c.	1	O/L
17	Nylon insert lock nut 5/8" n.c.	Écrou à garniture de nylon 5/8" n.c.	1	O/L
18	Hex. bolt 3/8" n.c. x 1 1/4"	Boulon hex. 3/8" n.c. x 1 1/4"	2	O/L
19	Flange nut 3/8" n.c.	Écrou à bride 3/8" n.c.	2	O/L
20	Square head set screw 5/16" n.c. x 1/2"	Vis à pression à tête carrée 5/16" n.c. x 1/2"	1	O/L
21	Carriage bolt 1/4" n.c. x 3/4"	Boulon à carrosserie 1/4" n.c. x 3/4"	1	O/L
22	Flat washer 5/16" hole	Rondelle plate 5/16" trou	1	O/L
23	Nylon insert lock nut 1/4" n.c.	Écrou a garniture de nylon 1/4" n.c.	1	O/L
24	V-Belt , A-61	Courroie en V , A-61	1	104523
25	V-Belt , B-130	Courroie en V , B-130	1	104887

O/L = Obtain Locally

PARTS BREAKDOWN

NORTHEAST DRIVE MECHANISM 700471

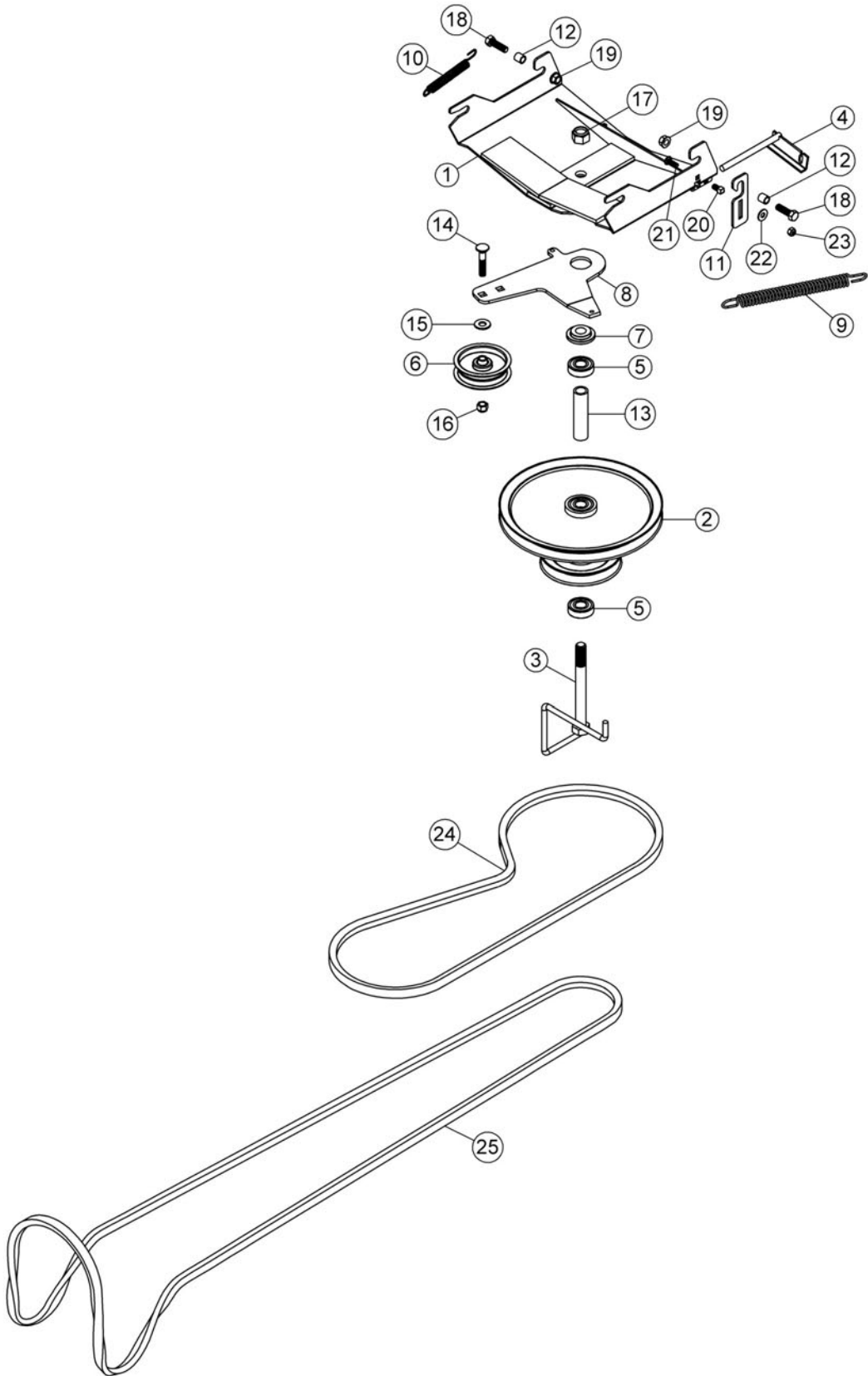

PARTS LIST

NORTHEAST DRIVE MECHANISM 700471

Ref. Réf.	English description	Description française	Qty. Qté.	Part # Pièce #
1	Drive frame	Châssis d'entraînement	1	104884
2	Double pulley inc. 102736 & 103035	Poulie double inc. 102736 & 103035	1	103040
3	Belt guide	Guide-courroie	1	104043
4	Adjustment rod	Tige d'ajustement	1	104841
5	Ball bearing	Roulement à billes	2	102736
6	Flat pulley	Poulie plate	1	102839
7	Flange washer	Rondelle à bride	1	102969
8	Idler arm	Bras de tension	1	104883
9	Spring	Ressort	1	102304
10	Spring 1/2"	Ressort 1/2"	1	102003
11	Latch	Loquet	1	104885
12	Sleeve	Douille	2	104886
13	Sleeve	Douille	1	103035
14	Carriage bolt 3/8" n.c. x 2"	Boulon à carrosserie 3/8" n.c. x 2"	1	O/L
15	Flat washer 7/16" hole	Rondelle plate 7/16" trou	1	O/L
16	Nylon insert lock nut 3/8" n.c.	Écrou à garniture de nylon 3/8" n.c.	1	O/L
17	Nylon insert lock nut 5/8" n.c.	Écrou à garniture de nylon 5/8" n.c.	1	O/L
18	Hex. bolt 3/8" n.c. x 1 1/4"	Boulon hex. 3/8" n.c. x 1 1/4"	2	O/L
19	Flange nut 3/8" n.c.	Écrou à bride 3/8" n.c.	2	O/L
20	Square head set screw 5/16" n.c. x 1/2"	Vis à pression à tête carrée 5/16" n.c. x 1/2"	1	O/L
21	Carriage bolt 1/4" n.c. x 3/4"	Boulon à carrosserie 1/4" n.c. x 3/4"	1	O/L
22	Flat washer 5/16" hole	Rondelle plate 5/16" trou	1	O/L
23	Nylon insert lock nut 1/4" n.c.	Écrou a garniture de nylon 1/4" n.c.	1	O/L
24	V-Belt , A-65	Courroie en V , A-65	1	104888
25	V-Belt , B-136	Courroie en V , B-136	1	104889

O/L = Obtain Locally

PARTS BREAKDOWN SUBFRAME 700469

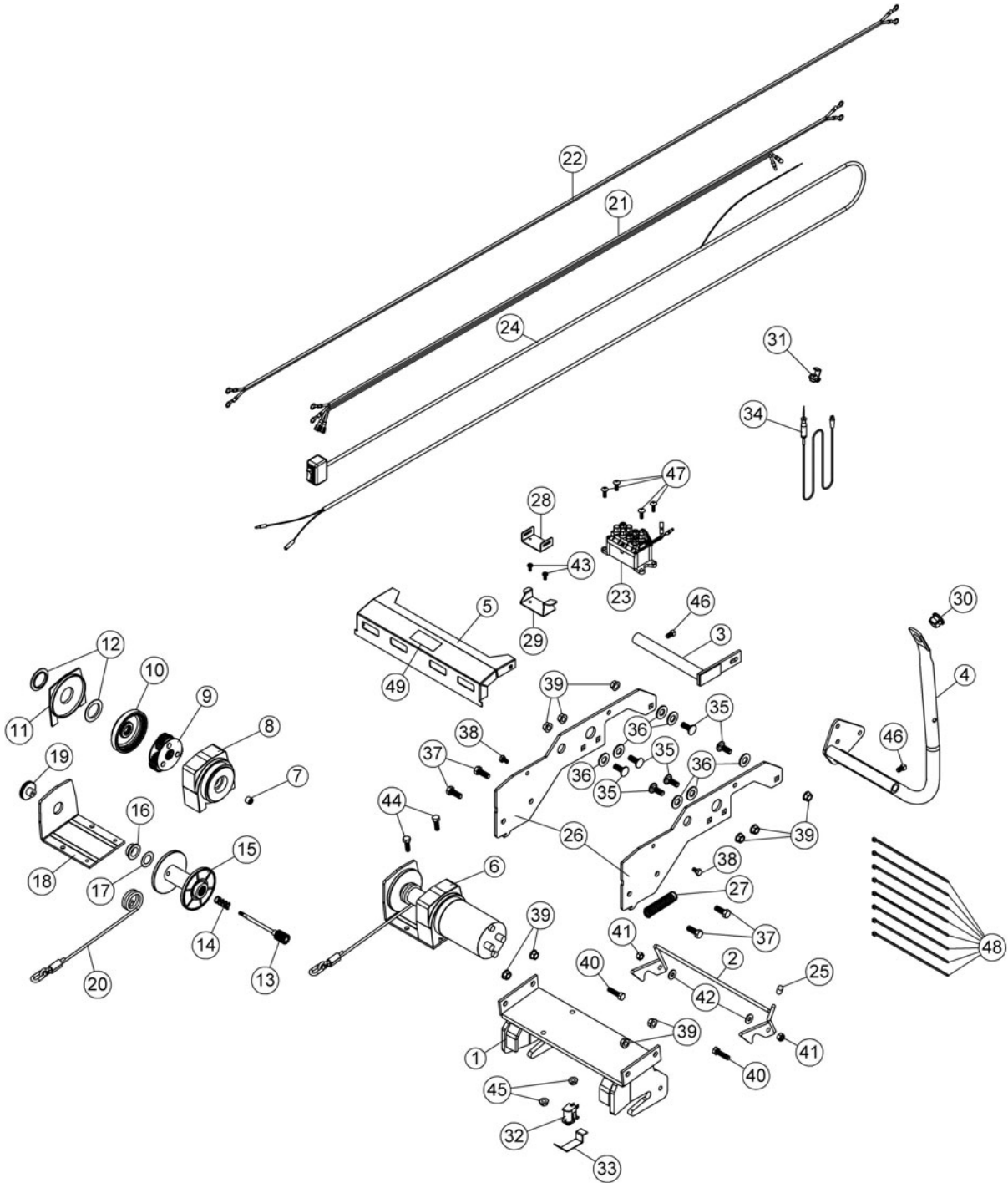

PARTS LIST SUBFRAME 700469

Ref. Réf.	English description	Description française	Qty. Qté.	Part # Pièce #
1	Female hitch	Attache femelle	1	104875
2	Latch	Loquet	1	104818
3	Cab support	Support de cabine	1	104878
4	Handle support	Support de manivelle	1	104879
5	Heat shield	Pare-chaleur	1	104880
6	Winch assembly	Treuil assemblé	1	104823
7	Roller bearing	Roulement à rouleaux	1	105137
8	Reduction box	Boîte de réduction	1	105138
9	Planetary gear	Engrenage planétaire	1	105139
10	Inner gear	Engrenage intérieur	1	105140
11	Drum support plate	Plaque de support du tambour	1	105141
12	Drum support bushing	Coussinet du support de tambour	2	105142
13	Spline shaft	Arbre à cannelures	1	105143
14	Spring	Ressort	1	105144
15	Drum	Tambour	1	105145
16	Bushing	Coussinet	1	105146
17	Adjusting washer	Rondelle ajustable	1	105147
18	Base plate assembly	Plaque de base assemblée	1	105148
19	Clutch handle	Poignée d'embrayage	1	105149
20	Winch cable	Cable du treuil	1	104827
21	Wire assembly	Fil assemblé	1	104830
22	Wire assembly	Fil assemblé	1	104831
23	Breaker	Fusible	1	104832
24	Winch control	Contrôle du Treuil	1	104829
25	Handgrip	Poignée	1	104825

O/L = Obtain Locally

PARTS LIST SUBFRAME 700469

Ref. Réf.	English description	Description française	Qty. Qté.	Part # Pièce #
26	Support	Support	2	104876
27	Spring	Ressort	1	103566
28	Control box	Base du contrôle	1	104820
29	Control support	Support du contrôle	1	104821
30	Plastic grommet	Oeillet de plastique	1	102063
31	Instant connector	Connecteur instantané	1	105152
32	Snap-mount switch	Commutateur à installation rapide	1	105136
33	Push plate	Plaque de poussée	1	105150
34	Hi/low voltage tester	Testeur de haute/basse tension	1	105151
35	Carriage bolt 3/8" n.c. x 1"	Boulon à carrosserie 3/8" n.c. x 1"	6	O/L
36	Flat washer 1/2" hole	Rondelle plate 1/2" trou	7	O/L
37	Hex. bolt 3/8" n.c. x 1"	Boulon hex. 3/8" n.c. x 1"	4	O/L
38	Hex. bolt 1/4" n.c. x 1/2"	Boulon hex. 1/4" n.c. x 1/2"	2	O/L
39	Flange nut 3/8" n.c.	Écrou à bride 3/8" n.c.	10	O/L
40	Hex. bolt 5/16" n.c. x 1 1/4"	Boulon hex. 5/16" n.c. x 1 1/4"	2	O/L
41	Nylon insert lock nut 5/16" n.c.	Écrou à garniture de nylon 5/16" n.c.	2	O/L
42	Flat washer 5/16" hole	Rondelle plate 5/16" trou	2	O/L
43	Metal screw pan head #8 x 1/2"	Vis à métal tête pan #8 x 1/2"	2	O/L
44	Hex. bolt 5/16" n.c. x 1"	Boulon hex. 5/16" n.c. x 1"	2	O/L
45	Flange nut 5/16" n.c.	Écrou à bride 5/16" n.c.	2	O/L
46	Square head set screw 5/16" n.c. x 1/2"	Vis à pression à tête carrée 5/16" n.c. x 1/2"	2	O/L
47	Metal screw T.H. #12 x 3/4"	Vis métallique T.H. #12 x 3/4"	4	O/L
48	Tie wrap 8"	Attache de nylon 8"	8	O/L
49	Decal caution hot surfaces	Décalque attention surfaces chaudes	1	105133

O/L = Obtain Locally

TORQUE SPECIFICATION TABLE

GENERAL TORQUE SPECIFICATION TABLE USE THE FOLLOWING TORQUES WHEN SPECIAL TORQUES ARE NOT GIVEN

NOTE: These values apply to fasteners as received from supplier, dry or when lubricated with normal oil. They do not apply if special graphited or moly disulphide greases or other extreme pressure lubricants are used. This applies to both UNF and UNC threads.

* Thick nuts must be used with grade 8 bolts

SEE Grade No.		2				5				8 *			
BOLT HEAD IDENTIFICATION MARKS AS PER GRADE NOTE MANUFACTURING MARKS WILL VARY		TORQUE				TORQUE				TORQUE			
BOLT SIZE		FOOT POUNDS		NEW TON-METERS		FOOT POUNDS		NEW TON-METERS		FOOT POUNDS		NEW TON-METERS	
Inches	Millimetre	Min.	Max.	Min.	Max.	Min.	Max.	Min.	Max.	Min.	Max.	Min.	Max.
1/4"	6.35	5	6	6.8	8.13	9	11	12.2	14.9	12	15	16.3	30.3
5/16"	7.94	10	12	13.6	16.3	17	20.5	23.1	27.8	24	29	32.5	39.3
3/8"	9.53	20	23	27.1	31.2	35	42	47.5	57	45	54	61	73.2
7/16"	11.11	30	35	40.7	47.4	54	64	73.2	86.8	70	84	94.9	113.9
1/2"	12.7	45	52	61	70.5	80	96	108.5	130.2	110	132	149.2	179
9/16"	14.29	65	75	88.1	101.6	110	132	149.2	179	160	192	217	260.4
5/8"	15.88	95	105	128.7	142.3	150	180	203.4	244.1	220	264	298.3	358
3/4"	19.05	150	185	203.3	250.7	270	324	366.1	439.3	380	456	515.3	618.3
7/8"	22.23	160	200	216.8	271	400	480	542.4	650.9	600	720	813.6	976.3
1"	25.4	250	300	338.8	406.5	580	696	786.5	943.8	900	1080	1220.4	1464.5

METRIC BOLT TORQUE SPECIFICATIONS							
		COARSE THREAD			FINE THREAD		
Size Screw	Grade No.	Pitch (mm)	Foot Pounds	Newton-Meters	Pitch (mm)	Foot Pounds	Newton-Meters
M6	4T	1.00	3.6 - 5.8	4.9 - 7.9	-	-	-
	7T		5.8 - 9.4	7.9 - 12.7		-	-
	8T		7.2 - 10	9.8 - 13.6		-	-
M8	4T	1.25	7.2 - 14	9.8 - 19	1.00	12 - 17	16.3 - 23
	7T		17 - 22	23 - 29.8		19 - 27	25.7 - 36.6
	8T		20 - 26	27.1 - 35.2		22 - 31	29.8 - 42
M10	4T	1.50	20 - 25	27.1 - 33.9	1.25	20 - 29	27.1 - 39.3
	7T		34 - 40	46.1 - 54.2		35 - 47	47.4 - 63.7
	8T		38 - 46	51.5 - 62.3		40 - 52	54.2 - 70.5
M12	4T	1.75	28 - 34	37.9 - 46.1	1.25	31 - 41	42 - 55.6
	7T		51 - 59	69.1 - 79.9		56 - 68	75.9 - 92.1
	8T		57 - 66	77.2 - 89.4		62 - 75	84 - 101.6
M14	4T	2.00	49 - 56	66.4 - 75.9	1.50	52 - 64	70.5 - 86.7
	7T		81 - 93	109.8 - 126		90 - 106	122 - 143.6
	8T		96 - 109	130.1 - 147.7		107 - 124	145 - 168
M16	4T	2.00	67 - 77	90.8 - 104.3	1.50	69 - 83	93.5 - 112.5
	7T		116 - 130	157.2 - 176.2		120 - 138	162.6 - 187
	8T		129 - 145	174.8 - 196.5		140 - 158	189.7 - 214.1
M18	4T	2.00	88 - 100	119.2 - 136	1.50	100 - 117	136 - 158.5
	7T		150 - 168	203.3 - 227.6		177 - 199	239.8 - 269.6
	8T		175 - 194	237.1 - 262.9		202 - 231	273.7 - 313
M20	4T	2.50	108 - 130	146.3 - 176.2	1.50	132 - 150	178.9 - 203.3
	7T		186 - 205	252 - 277.8		206 - 242	279.1 - 327.9
	8T		213 - 249	288.6 - 337.4		246 - 289	333.3 - 391.6

ATTACHMENTS

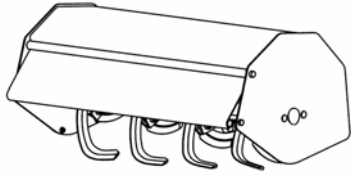

ROTARY TILLER #700312

Mounts to the rear of lawn, yard & garden tractors 14 to 25 HP. Comes complete with drive & manual lift mechanisms & mounting hardware

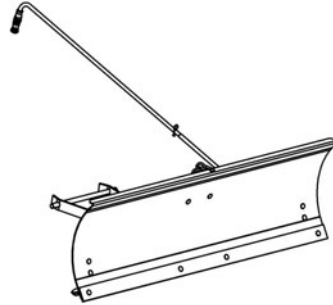

BLADE #700463

Mounts on the same subframe as the snowblower & rotary broom.

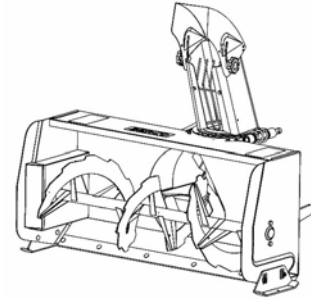

SOUFFLEUSE
700465 40"
700474 44"
700478 48"

Mounts on the same subframe as the blade & rotary broom.

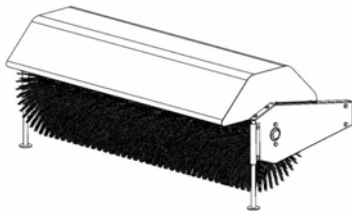

ROTARY BROOM
#700380 with nylon brush
#700381 with polypropylene brush.

Fits on same subframe as snowblower & utility blade. Requires an adaptor.

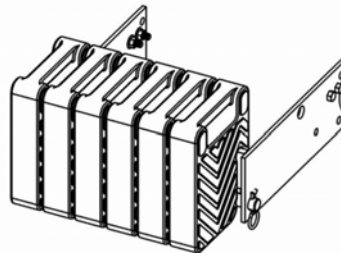

COUNTERWIEGHT

According to tractor model

Required for safety and traction. Counterbalances weight of attachment.

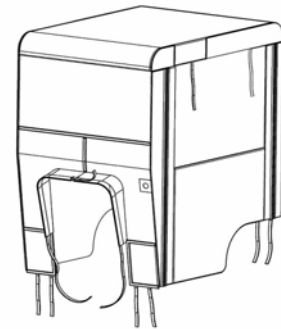

TRACTOR WINTER CAB
#700271 34"
#700423 40"

Universal type fits on a wide variety of lawn and garden tractors.

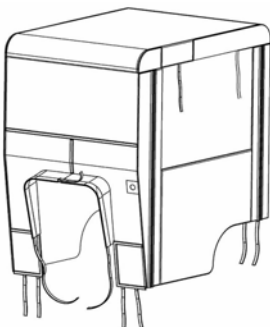

TRACTOR SCREEN CAB
700313 34"
#700424 40"

Universal type fits on a wide variety of lawn and garden tractors.

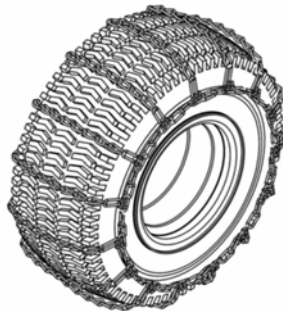

TIRE CHAINS

Two link spacing. Required for traction and safety.
Pkg. of 2

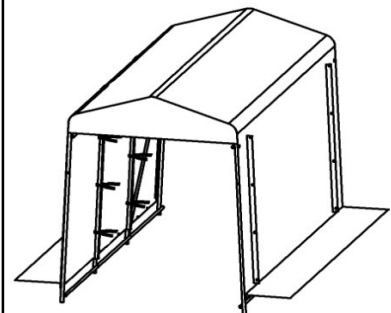

WINTER SHELTER #700438
Perfect to protect the tractors, A.T.Vs and snowmobiles from the weather.
Dimensions: 5'W x 12'L x 7' 8"H



***WHEN PERFORMANCE
& DEPENDABILITY
ARE NON NEGOTIABLE!***

Bercomac Limitée
92, Fortin North, Adstock, Quebec, Canada, G0N 1S0

WWW.BERCOMAC.COM

PRINTED IN CANADA