

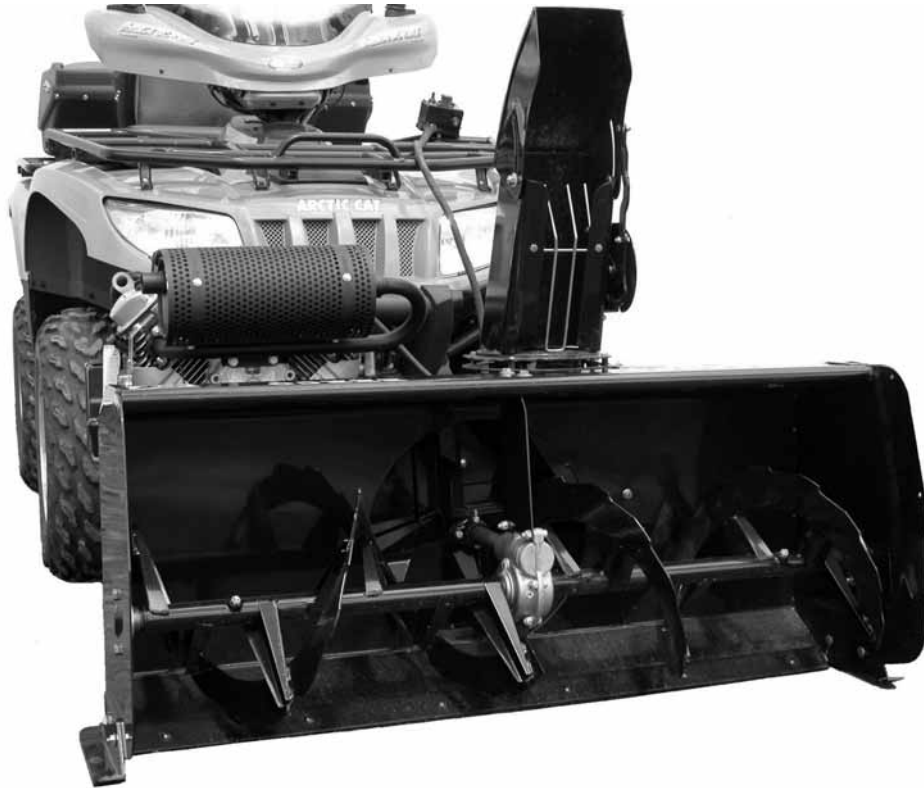

**OWNER'S MANUAL**  
***Model Number***  
***700480***



***BERCO VERSATILE***  
***Two Stage 48" Snowblower***  
***For***  
***ALL TERRAIN VEHICLES***

- \* ASSEMBLY
- \* OPERATION

- \* REPAIR PARTS
- \* MAINTENANCE

**CAUTION:**  
READ & FOLLOW ALL SAFETY RULES & INSTRUCTIONS BEFORE  
OPERATING YOUR EQUIPMENT

# LIMITED WARRANTY

## **Conditions and Products Covered:**

BERCOMAC guarantees any part of the product or accessory manufactured by BERCOMAC and found in the reasonable judgment of BERCOMAC to be defective in material and or workmanship will be repaired or replaced by an authorized dealer without charge up to our maximum labor rates and pre-established times. For replacement parts only standard ground freight services are covered. This warranty extends to the original retail purchaser only and is not transferable to any subsequent purchasers.

### **Warranty Period**

(from date of the original retail purchase):

- Residential use: 1 year
- Commercial or rental use: 90 days

**Exceptions Noted Below:** the following items are guaranteed by the original manufacturer and have their own warranty, conditions and limited time.

- Tire Chains: 90 days
- Engines (installed on BERCO equipment): 2 years
- Engines (sold separately): Validate with the dealer.

Please refer to the engine manufacturer's warranty statement included with the unit. Bercomac is not authorized to handle warranty adjustments on engines.

## **Items and Conditions NOT Covered:**

This warranty does not cover the following:

- Pick-up or delivery charges or in-home services fees.
- Any damage or deterioration of the unit, parts and or finish of these due to normal use, wear and tear, or exposure.
- Cost of regular use or maintenance service or parts, such as gas, oil, lubricants, tune-up parts, and adjustments.
- Any part or accessory which has been altered, modified, misused, neglected, accidentally damaged or not properly installed, maintained, stored or repaired not in accordance with the instructions in the owner's manual.
- Repair due to normal wear and or any wear items such as shear pins, bolts, belts, etc.
- Expedited freight fee services for replacement parts.
- Shear bolts and shear pins are to be considered as a preventive measure not as an assured protection, any damages resulting from the lack of shear bolts breakage are not covered.

NOTE: All warranty work must be performed by an authorized

**Note:** BERCOMAC reserves the right to change or improve the design of any part or accessory without assuming any obligation to modify any product previously manufactured.

## **Instructions for Obtaining Warranty Services:**

Contact dealer where equipment was purchased or any other Authorized Service Dealer to arrange service at their dealership. Bring the product and your proof of purchase (sales receipt). Requests for warranty claims must be carried out through the same distribution network used to purchase the product.

dealer using original (manufacturer) replacement parts.

## **Owner's Responsibilities:**

Any defective equipment or part must be returned to an authorized dealer within the warranty period for repairs. In the event that defective merchandise must be returned to manufacturer for repairs, the dealer must first obtain a written authorization from either KIMPEX or BERCOMAC, freight fees are prepaid prior to the shipment. This warranty extends only to equipment operated under normal conditions. To validate a warranty claim, it is the user's responsibility to maintain and service the unit as specified in the owner's manual or to have the unit serviced at their dealer at their expense.

## **General Conditions:**

The sole liability of BERCOMAC with respect to this warranty shall be strictly and exclusively repair and replacement as mentioned herein. BERCOMAC shall not have any liability for any other costs, loss or damage, including but not limited to, any incidental or consequential loss or damage.

In particular, without being limited to, BERCOMAC shall have no liability or responsibility for:

- Travel time, overtime, after hours time or other extraordinary repair charges or relating to repairs and or replacements outside of normal business hours.
- Rental of like or similar replacement equipment during the period of any, repair or replacement work.
- Any communicating or travel charges.
- Loss or damage to person or property other than that covered by the terms of this warranty.
- Any claims for lost revenue, lost profit or any similar costs as a result of damage or repair.
- Attorney's fees.

BERCOMAC'S responsibility in respect to claims is limited to making the required repairs or replacement without charge up to our maximum labor rates and pre-established times and no claim of breach of warranty shall be cause for cancellation or rescission of the contract of sale of any product or accessory.

This warranty gives you specific legal rights. You may also have other rights, which vary from state to state.

# TABLE OF CONTENTS

	PAGE
INTRODUCTION .....	2
SAFETY PRECAUTIONS .....	3
SAFETY DECALS .....	5
ASSEMBLY	
Step 1: Snowblower Preparation .....	6
Step 2: Engine Installation .....	8
Step 3: Subframe Preparation .....	11
Step 4: Vehicle Preparation .....	13
Step 5: Control Box Installation .....	14
Step 6: Final Adjustments .....	17
OPERATION	
Operating the Snowblower .....	19
Electrical Controls .....	19
Removing Snow .....	19
Clearing a Clogged Discharge Chute .....	19
MAINTENANCE & DISMOUNTING	
Maintenance .....	20
Adjustments .....	20
Lubrication .....	20
Cutting Edge Maintenance .....	20
Auger and Fan Shear Bolt Replacement .....	20
Dismounting .....	20
Storage .....	20
BELT REPLACEMENT .....	21
TROUBLESHOOTING .....	22
TORQUE SPECIFICATION TABLE .....	23
PARTS BREAKDOWN AND PARTS LIST	
Rotation System with Chute .....	24
Subframe .....	26
Snowblower .....	28
OPTIONS & ACCESSORIES .....	32

# INTRODUCTION

## TO THE PURCHASER

This new attachment was carefully designed to give years of dependable service. This manual has been provided to assist in the safe operation and servicing of your attachment.

**NOTE:** All photographs and illustrations in the manual may not necessarily depict the actual models or attachment, but are intended for reference only and are based on the latest product information available at the time of publication.

Familiarize yourself fully with the safety recommendations and operating procedures before putting the machine to use. Carefully read, understand and follow these recommendations and insist that they be followed by those who will use this attachment.



**THIS SAFETY ALERT SYMBOL IDENTIFIES AN IMPORTANT SAFETY MESSAGE IN THIS MANUAL THAT HELPS YOU AND OTHERS AVOID PERSONAL INJURY OR EVEN DEATH. DANGER, WARNING, AND CAUTION ARE SIGNAL WORDS USED TO IDENTIFY THE LEVEL OF HAZARD. HOWEVER, REGARDLESS OF THE HAZARD, BE EXTREMELY CAREFUL.**

**DANGER:** Signals an extreme hazard that will cause serious injury or death if recommended precautions are not followed.

**WARNING:** Signals a hazard that may cause serious injury or death if the recommended precautions are not followed.

**CAUTION:** Signals a hazard that may cause minor or moderate injury if the recommended precautions are not followed.

Record your attachment serial number and purchase date in the section reserved below (there is no serial number on the subframe). Your dealer requires this information to give you prompt, efficient service when ordering replacement parts. Use only genuine parts when replacements are required.

If warranty repairs are required please present this registration booklet and original sales invoice to your selling dealer for warranty service.

**This manual should be kept for future reference.**

**Please check if you have received all the parts for your kit with the list of the bag and the list of the box.**

**SERIAL NUMBER :** \_\_\_\_\_

**PURCHASE DATE :** \_\_\_\_\_

# SAFETY PRECAUTIONS

Careful operation is your best insurance against an accident. Read this section carefully before operating the vehicle and accessory. This accessory is capable of amputating hands and feet and throwing objects. Failure to observe the following safety instructions could result in serious injury. All operators, no matter how experienced they may be, should read this and other manuals related to the vehicle and accessory before operating. It is the owner's legal obligation to instruct all operators in safe operation of the accessory.

## **GLOSSARY:**

In this manual, right and left sides are determined by sitting on the seat of the vehicle facing forward.

In this manual, "accessories" means attachments (snowblower, rotary broom, blade etc.) that you install on the vehicle (lawn tractors, A.T.V. s etc).

## **TRAINING:**



This symbol, "Safety Alert Symbol", is used throughout this manual and on the accessory's safety labels to warn of the possibility of serious injury. Please take special care in reading and understanding the safety precautions before operating the vehicle and accessory.

1. Read this owner's manual carefully. Be thoroughly familiar with the controls and proper use of the vehicle and accessory. Know how to stop the unit and disengage the controls quickly.
2. Never allow children to operate the vehicle nor the accessory. Never allow adults to operate the vehicle nor the accessory without proper instructions.
3. No one should operate the vehicle nor the accessory while intoxicated or while taking medication that impairs the senses or reactions.
4. Keep the area of operation clear of all people, particularly small children and pets.

## **PREPARATION:**

1. Thoroughly inspect the area where the accessory is to be used and remove door mats, all foreign objects and the like.
2. For motorized accessories, disengage all clutches and shift into neutral before starting engine.
3. Do not operate the accessory without wearing adequate winter outer garments. Avoid loose fitting clothing that can get caught in moving parts. Wear footwear that will improve footing on slippery surfaces.

4. Handle fuel with care, it is highly flammable.
  - a) Use approved fuel container.
  - b) Never add fuel to a running engine or hot engine.
  - c) Fill fuel tank outdoors with extreme care. Never fill fuel tank indoors.
  - d) Never fill containers inside a vehicle, or on a truck or a trailer bed with a plastic liner. Always place containers on the ground, away from your vehicle, before filling.
  - e) When practical, remove gas-powered equipment from the truck or trailer and refuel it on the ground. If this is not possible, then refuel such equipment on a trailer with a portable container, rather than from a gasoline dispenser nozzle.
  - f) Keep the nozzle in contact with the rim of the fuel tank or container opening at all times, until refueling is complete. Do not use a nozzle lock-open device.
  - g) Replace fuel cap securely and wipe up spilled fuel.
  - h) If fuel is spilled on clothing, change clothing immediately.
5. Never attempt to make any adjustments while the engine (motor) is running (except when specifically recommended by manufacturer).
6. Let the vehicle and accessory adjust to outdoor temperatures before starting to clear snow.
7. Always wear safety glasses or eye shields during operation or while performing an adjustment or repairs to protect the eyes from foreign objects that may be thrown from the accessory.
8. **Never modify the accessory or any part without the written consent from the manufacturer.**

# SAFETY PRECAUTIONS

## OPERATION:

1. Do not put hands or feet near, under or inside rotating parts.
2. Exercise extreme caution when operating on or crossing gravel drives, walks or roads. Stay alert for hidden hazards or traffic. Do not carry passengers.
3. After striking a foreign object, stop the engine (motor), disconnect the wire from the spark plug(s) and keep wire away to prevent accidental starting. Thoroughly inspect the accessory for any damage and repair damage before restarting and using the accessory.
4. If the unit should start to vibrate abnormally, stop the engine (motor) and check immediately for the cause. Vibration is generally a warning of trouble.
5. Take all possible precautions when leaving the vehicle unattended. Disengage the power take-off, lower the attachment, place the transmission into neutral, set the parking brake, stop the engine and remove the contact key.
6. Do not run the engine indoors, except when starting the engine and for transporting in or out of the building. Do not operate or let motor run in a storage area without ventilation because gas contains carbon monoxide which is odorless, colorless and can cause death.
7. Never clean across the face of slopes, go from top to bottom. Exercise extreme caution when using equipment on slopes. Do not attempt to clear a steep slope.
8. Never use an accessory without proper guards, plates, or other safety protective devices in place
9. Never tolerate bystanders in the working zone. Never use an accessory in the direction of bystanders, it might throw gravel or debris that can hurt people or damage property.
10. Never operate the accessory at high transport speeds on slippery surfaces. Use care when backing up.
11. Do not carry passengers.
12. Disengage power to the accessory when it is transported or not in use.

13. Never operate the accessory without good visibility or light.
14. Keep the accessory away from heat sources or flames.
15. Always wear a dust mask when working in a dusty environment.

## MAINTENANCE AND STORAGE

1. When cleaning, repairing or inspecting the vehicle and accessory, make certain that all moving parts have stopped. Disconnect wire from the spark plug (s) and keep wire away to prevent accidental starting.
2. Check all the bolts at frequent intervals to make sure that they are properly tightened .
3. Never store a motorized accessory with fuel in the fuel tank inside a building where ignition sources are present such as hot water and space heaters, clothes dryers, and the like. Allow the engine to cool before storing in any enclosure.
4. Always refer to the owner's manual when you store the accessory and vehicle for a prolonged or an unspecified length of time.
5. Maintain or replace safety and instruction labels, as necessary.
6. For winter accessories, (if applicable), let the engine run for a few minutes after clean snow in order to prevent the rotary parts from freezing.
7. Inspect the vehicle's and accessory's air filter every day. Clean it or replace it as necessary. Change the oil more often when working in dusty conditions. See the vehicle's and accessory's owner's manual.

**WHENEVER YOU SEE THIS SYMBOL**



**IT MEANS:  
WARNING!  
BECOME ALERT !  
YOUR SAFETY IS INVOLVED!**

# SAFETY DECALS

REPLACE IF DECALS ARE DAMAGED  
SEE PARTS BREAKDOWN FOR DECAL LOCATION



Decal # 102125



Decal # 102126



Decal # 102128



Decal # 103951



Decal # 102553



Decal # 102127

# ASSEMBLY

**IMPORTANT: TORQUE ALL BOLTS ACCORDING TO TORQUE SPECIFICATION TABLE (SEE TABLE OF CONTENTS) WHEN STATED: TIGHTEN FIRMLY. REFER TO PARTS BREAKDOWN SECTION FOR PART IDENTIFICATION.**

## **STEP 1**

### **SNOWBLOWER PREPARATION:**

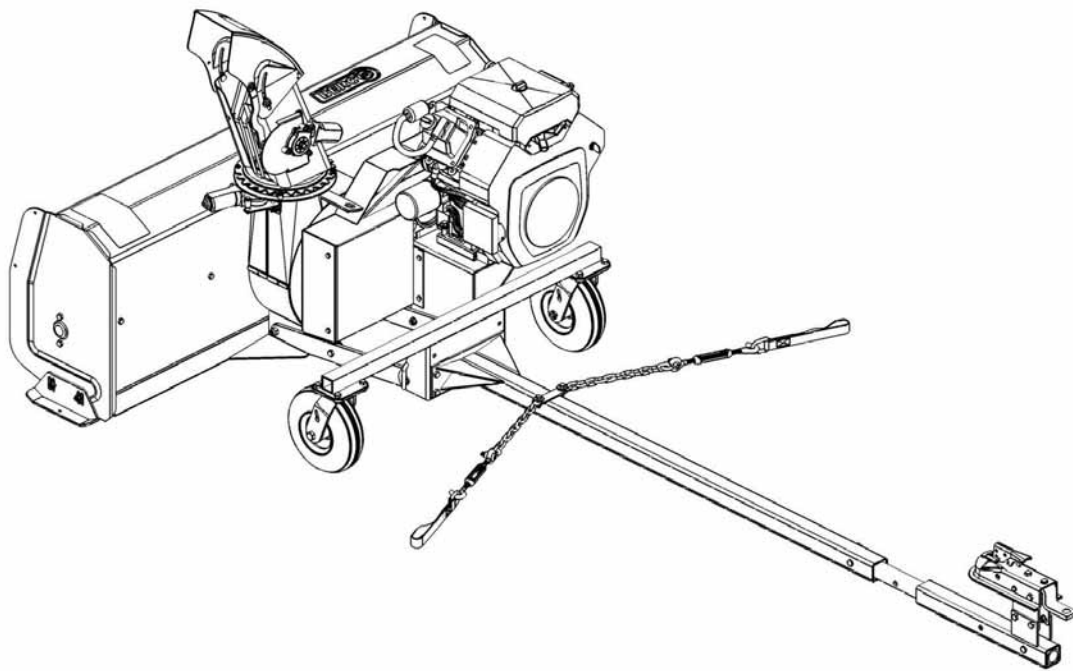

Overall view of snowblower



## ASSEMBLY

Install the rotation ring (item 1) over opening (item 2) as shown and align the notches.

Place the chute (item 3) (facing the rear) and clip the back over the rotation ring then turn the chute towards the front to lock into place.

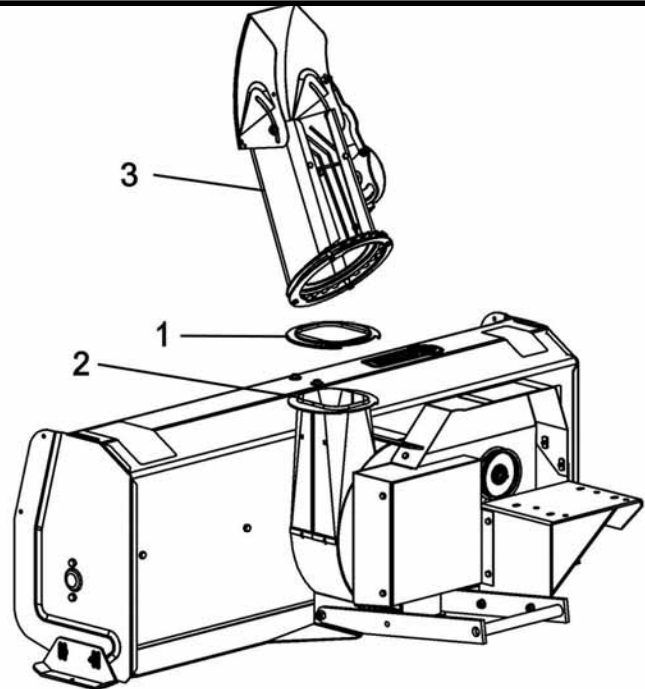

Install chute

Install two carriage bolts 1/4" x 1" (item 1) inside the base of the chute. Install the support (item 2) and the motor assembly (item 3) on the bolts. Tighten into place with two flange nuts.

**NOTE:** Make sure the pin (item 4) on the electric motor is well inserted in the hole on the support.

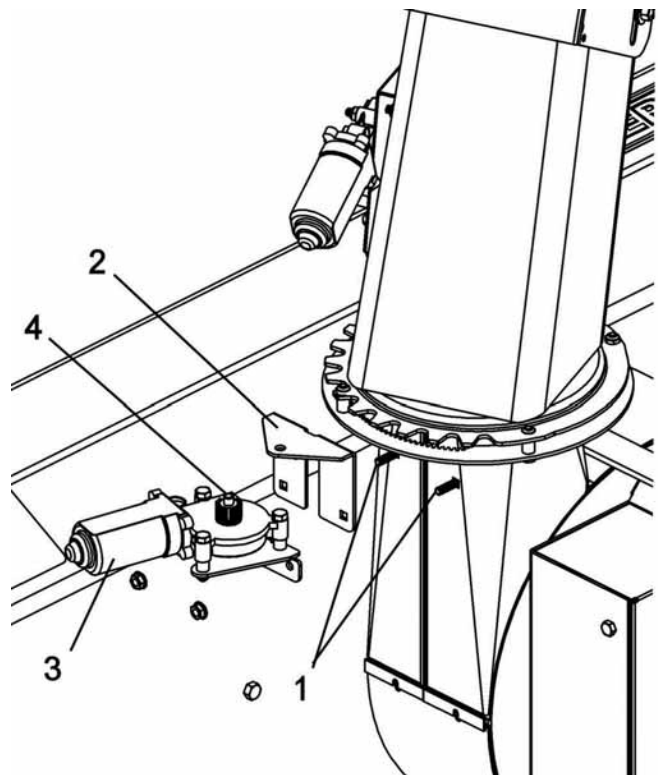

Install the motor assembly

# ASSEMBLY

## STEP 2 ENGINE INSTALLATION:

**IMPORTANT:** We recommend using a 13 to 23 hp. engine with a 1" horizontal shaft on this snowblower

HERE ARE A FEW SUGGESTION OF ENGINES THAT HAVE BEEN TESTED.

Tested engines			
	<i>Honda engines</i>		<i>Kohler engine</i>
<b>HP</b>	<b>18 hp</b>	<b>20 hp</b>	<b>20 hp</b>
<b>Shaft</b>	1"	1"	1"
<b>Model</b>	GX610U QZE6	GX620K QXA6	PA64714
<b>Muffler</b>	VHLM3	VHLM3	KH.24 786 06
<b>Gas tank</b>	Not included	Not included	Not included
<b>Pulley</b>	MB-31 (#104833)	M-31 (#104833)	MB-31 (#104833)

**NOTE:** The gas tank kit (option #700462 is recommended when it is not included with the engine.

**IMPORTANT: THE RIGHT INSTALLATION OF THE ENGINE IS CRUCIAL TO THE GOOD WORKING ORDER OF THE SNOWBLOWER.**

**NOTE:** Figures 1 and 2 show an engine that is not well positioned.

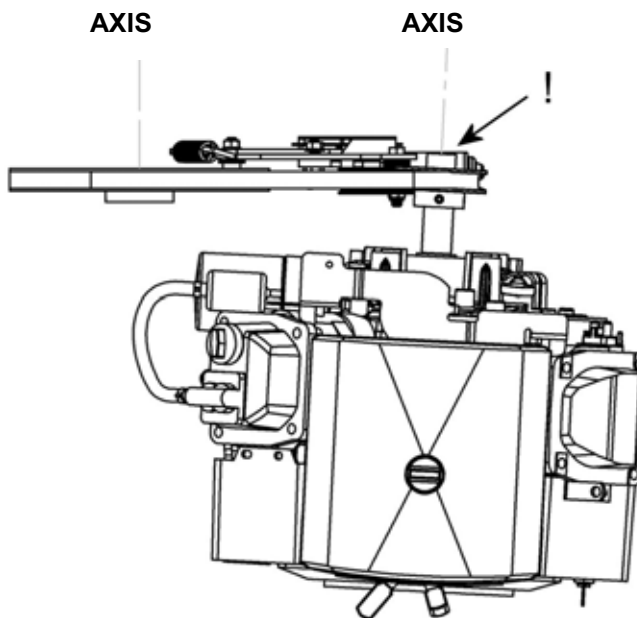

Top view  
Figure 1 Engine not in right position

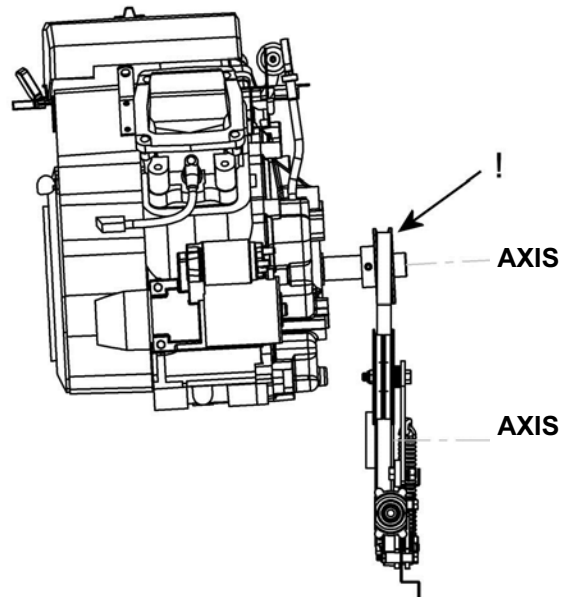

Side view  
Figure 2 Engine not in right position

# ASSEMBLY

## MOTOR INSTALLATION

For engines with an electric starter, it is necessary to connect the vehicle's battery to the starter on the snowblower engine. **You must obtain option 700476 to allow this connection.**

Remove the belt guard (item 3) by removing the three 1/4"x 1/2" hex. bolts (item 4).

**IMPORTANT:** The center of the shaft (item 1) must be 4.88" and 2.13" from the frame of the snowblower (see dimensions on the figure).

Place the engine on the stand (item 5). Use two 1" shims (item 2) if required, to attain the height of 2.13" as shown.

If more or less height is needed, use a couple of flat washers.

Choose the set of holes on the stand that correspond with those on the engine and to the position of the engine shaft.

Secure with four hex. bolts 3/8" x 1 3/4" or 3/8" x 2 3/4", flat washers (on the slots if applicable) and flange nuts.

**NOTE:** Make sure that the stand for the engine (item 4) is parallel with the snowblower frame.

Tighten the bolts firmly.

### **DANGER:**

**It is the responsibility of the person who installs the engine and the controls to make sure that the engaging system works well and that the snowblower disengages effectively at all times. It is imperative to make the necessary adjustments if applicable.**

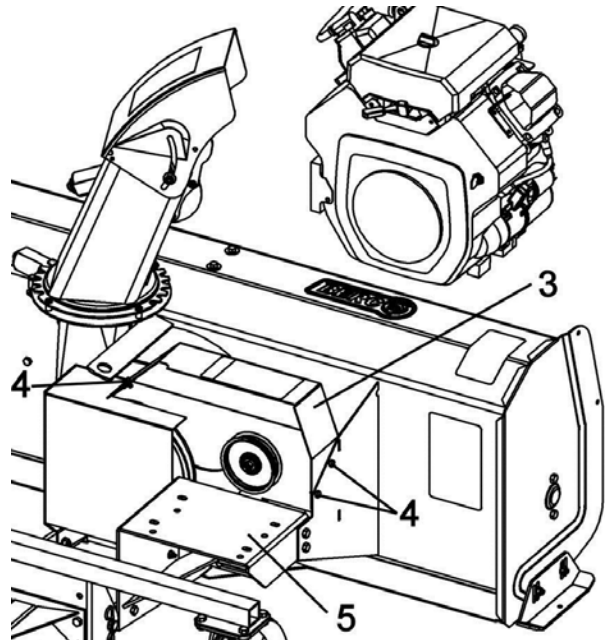
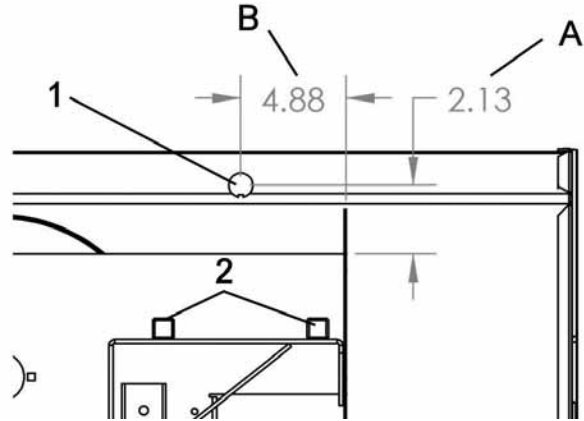

Install engine

# ASSEMBLY

Choose the right pulley (#104833 = 1" or #104839 = 1 1/8") (item 1) according to the diameter of the engine's shaft.

Install the pulley (Fig. 1, item 1) on the engine shaft as shown (hub towards the engine) with a 1/4" x 1/4" x 1 3/4" key.

After positioning the engine, it is very important that the pulleys are aligned and the axis must be parallel as shown in the two views: (fig. 1) top view of the snowblower and (fig. 2) the side view of the snowblower.

(Use some shims if necessary).

**Tip:** Use a ruler (item 4) on the pulleys

Tighten the set screw firmly.

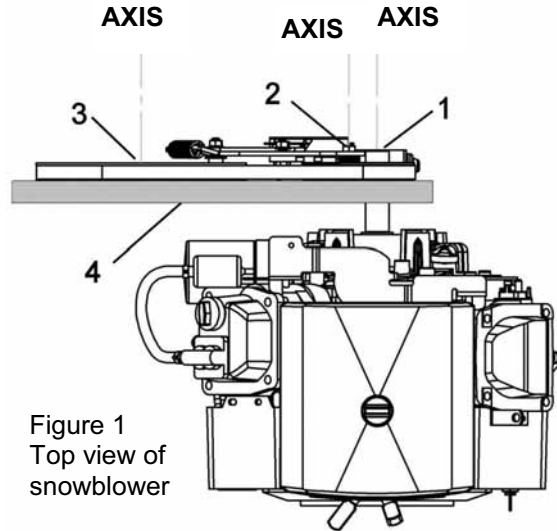

Figure 1  
Top view of snowblower

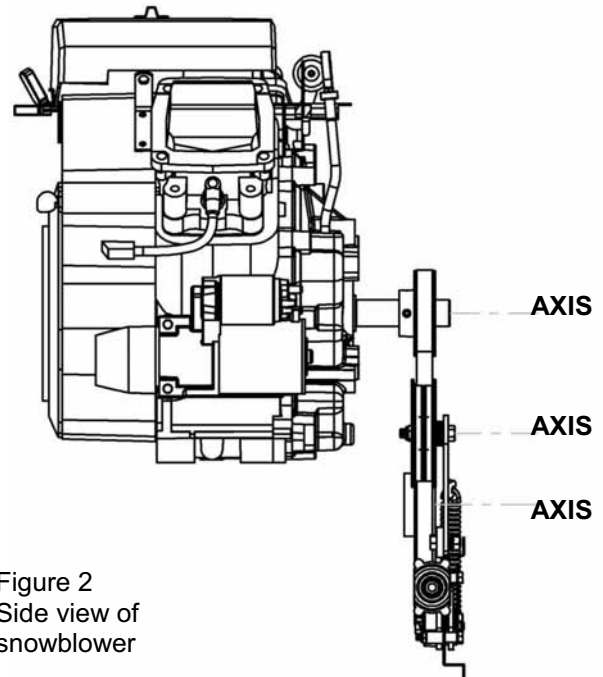
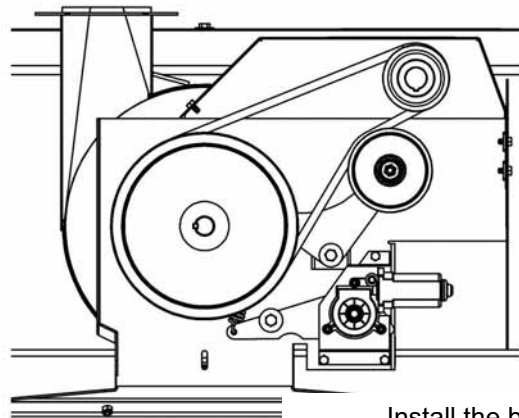

Figure 2  
Side view of snowblower

Install the belts on the snowblower pulleys as shown.

**NOTE:** The adjustment with the tension on the belts will be done in Step 6.



Install the belt

# ASSEMBLY

## STEP 3

### SUBFRAME PREPARATION:

Determine according to the height of the vehicle which set of holes to use to assemble the wheel support (item 1) to the subframe (item 2).

The subframe must be parallel with the ground when the subframe is installed under the vehicle.

Install the wheel support (item 1) to the subframe (item 2) by using four  $\frac{3}{8}$ " x 1" hex. bolts (item 3), four flange nuts.

Tighten the bolts firmly.

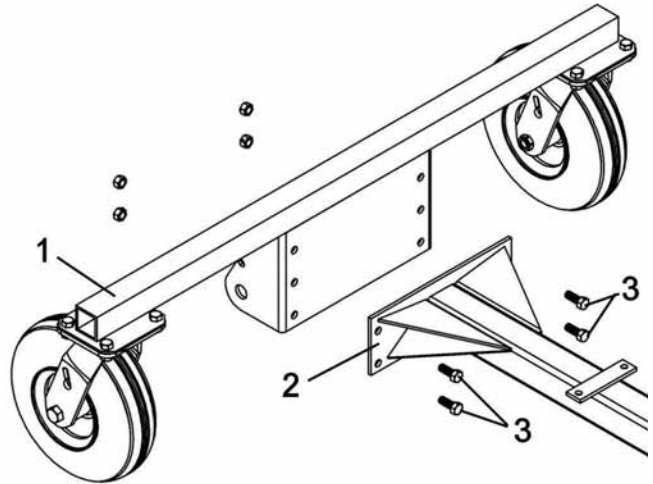

Install the wheel support to the subframe

Install the assembled turnbuckles (item 1) on the subframe (item 2).

Secure with two  $\frac{5}{16}$ " x 1" hex bolts (item 3), two  $\frac{3}{8}$ " flat washers and nylon insert lock nuts.

Tighten loosely enough to allow the parts to move freely.

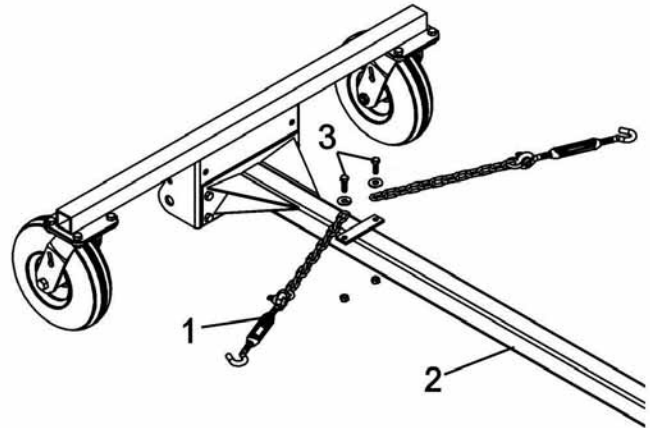

Install the assembled turnbuckles

Install the snowblower hitch (item 1) to the wheel support (item 2) with the pin (item 3). Make sure the pin is in the locked position.

Secure with the 4mm hair pin (item 4).

Tighten firmly.

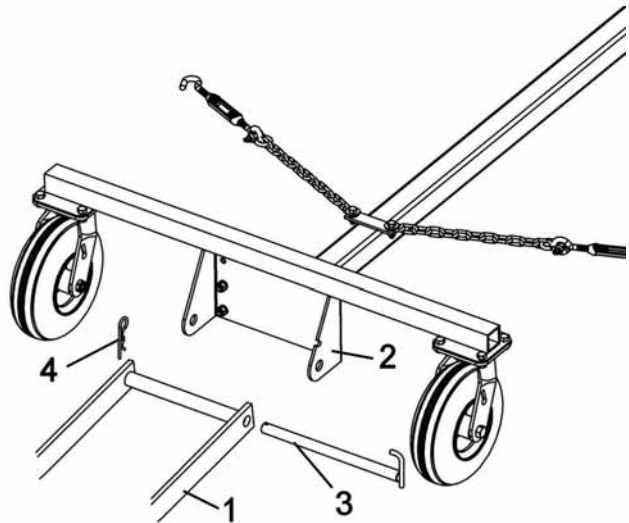

Install snowblower hitch

# ASSEMBLY

You have nine different positions on the adjustment tube (item 1) (the adjustment tube can be inverted) to adjust the length of the subframe.

To choose the right adjustment, insert the adjustment tube (item 1) into the subframe (item 2) and insert the hitch support (item 3) on the adjustment tube. Do not secure.

Turn the hitch support to the side to facilitate installation.

Drive the vehicle over the subframe, make sure the caster wheels do not touch the front wheels on the vehicle.

Identify the right length and secure in place with a pin (item 4) and 3mm hair pin (item 5).

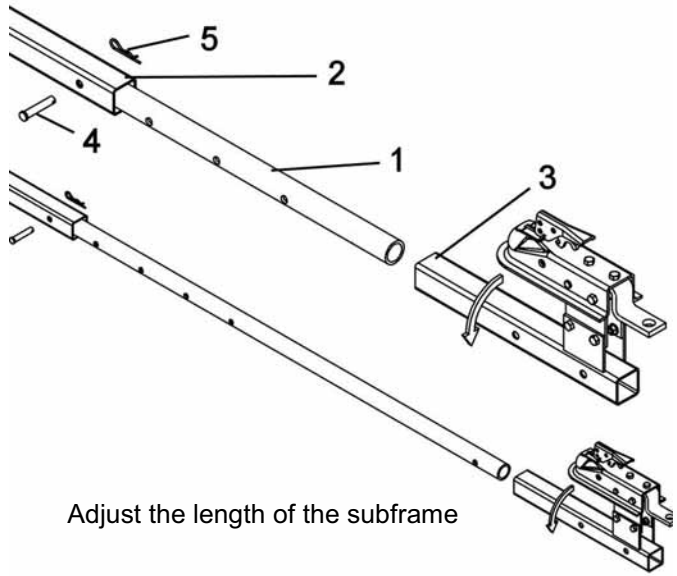

Choose between the three positions (see figure), the height of the hitch support.

There must be a maximum of ground clearance according to your vehicle.

Assemble the hitch support (items 1 & 2) with four 3/8" x 3/4" hex. bolts (item 3) and flange nuts (two on each side). Position A does not have the hitch supports (item 1).

Install the hitch (item 4) with a 3/8" x 3" hex bolt (item 5) and nylon insert lock nut.

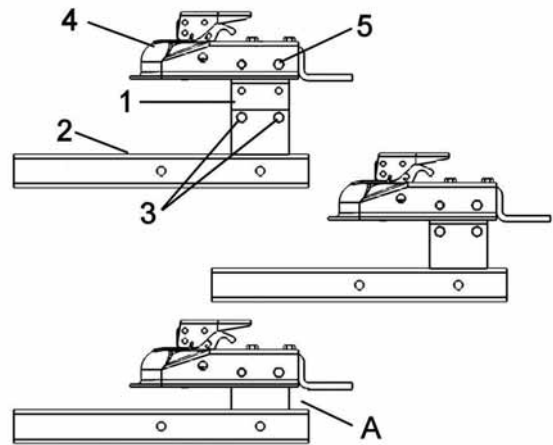

Assemble the hitch support

Insert the assembled hitch support (item 1) onto the adjustment tube (item 2). Secure in place with the pin (item 3) and the 3mm hair pin (item 4).

**NOTE:** The hitch support has two sets of holes to increase the length of the subframe if necessary.

Attach the hitch assembly on the tow hitch ball of the vehicle.

Insert the pin (item 5) and secure with a 3 mm hair pin (item 6). Make sure the subframe does not come into contact with vehicle at any time.

**NOTE:** You can turn the hitch assembly (item 1) to facilitate displacing the vehicle over the subframe by removing the pin (item 3).

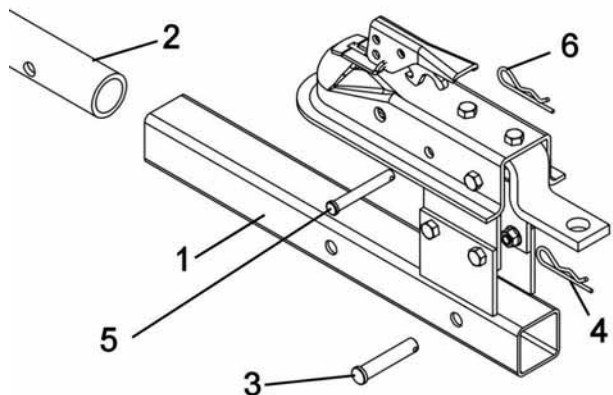

Secure the hitch support on the tow hitch ball

# ASSEMBLY

## STEP 4

### VEHICLE PREPARATION:

**NOTE:** A 1 7/8" tow hitch ball is required.

Remove the nut from the front suspension arm (item 1) on the vehicle and install the bracket (item 2). Secure loosely with the original nut. Do the same for the other side.

If you can not install the brackets on your vehicle, install the lift strap (item 3) by looping it around the suspension arm (as shown) on the vehicle.

Tighten the loop firmly.

Do the same for the other side.

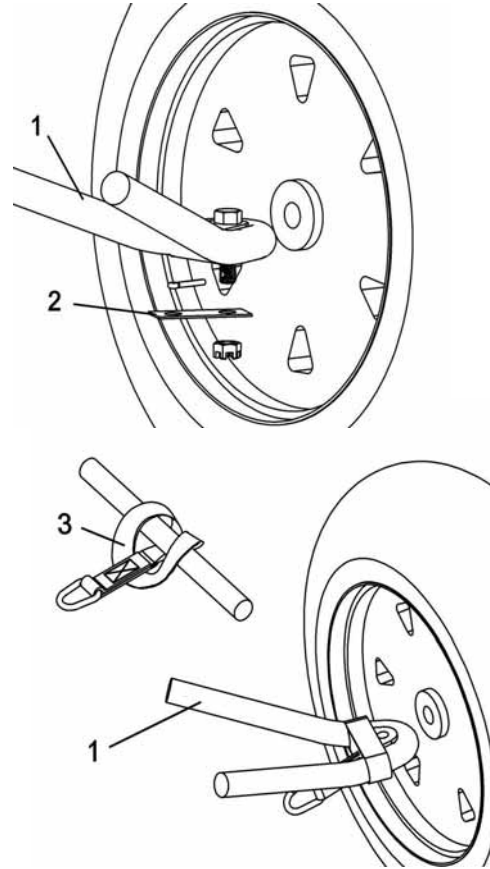

Hook the turnbuckles (item 1) into the brackets (item 2) or into the lift straps (item 3) and adjust them so the subframe is centered under the vehicle.

Tighten firmly the turnbuckles to stiffen the vehicle's suspension.

### **IMPORTANT:**

After adjusting the turnbuckles, tighten the nuts on the vehicle's wheel supports firmly.

Make sure to lock the nuts with the original locks.

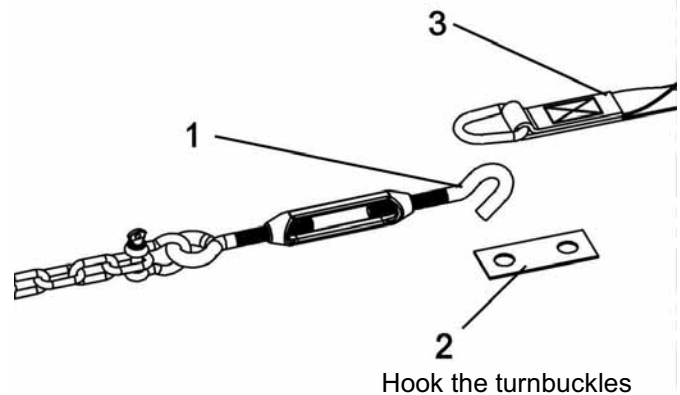

Insert the hook of the winch (item 1) into the flat bar welded on the top of the snowblower.

**NOTE:** Optional kit #700269 Lift connection kit reduces the effort and the speed required by the winch to lift the accessory.

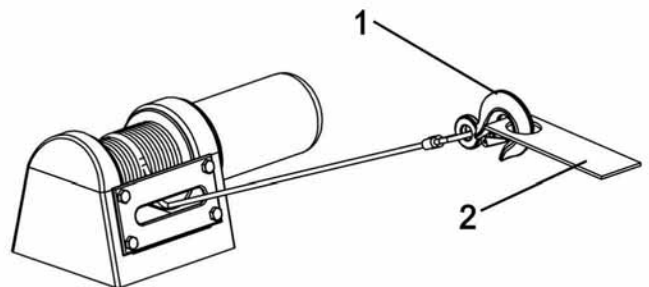

Install the winch cable

# ASSEMBLY

## STEP 5 CONTROL BOX INSTALLATION:

Three possible positions

Choose between the three different ways of securing the control box support (item 1). Use two hex bolts  $1/4" \times 1/2"$  or  $1 1/2"$  (items 6 or 2), support brackets (item 4), spacers (item 3) and flange nuts.

Insert the control box (item 5) in the support.

Connect the three connectors at the end of the control box wire to the three corresponding electric motors: short wire on the motor for the chute (A), medium wire on the motor for the deflector (B), long wire on the motor for the belt tensioner (C) and the circuit breaker wire (D).

There will be one black connector that will not be connected. This is to connect the optional snowblower light (E).

Make sure the connectors are well connected together.

**NOTE: If the switches don't match the right controls, reconnect the connectors with the right motors.**

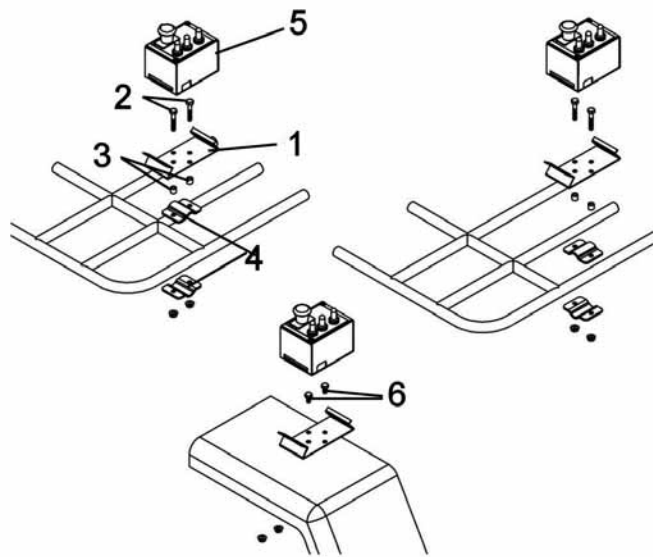

Install the control box and wires to the motors.

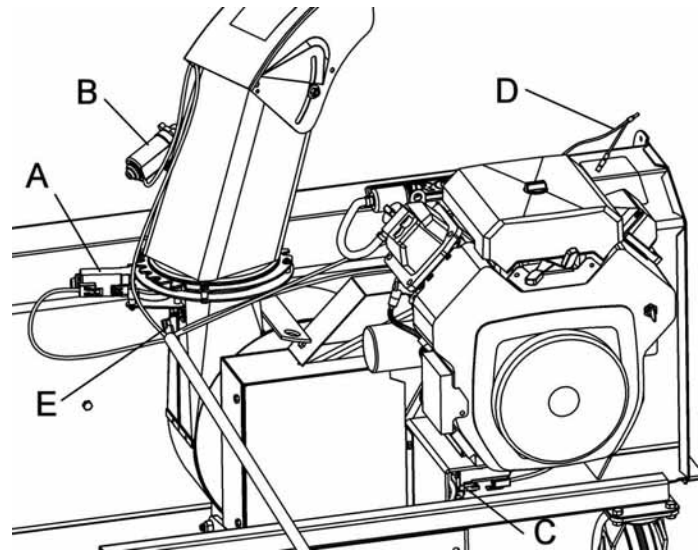
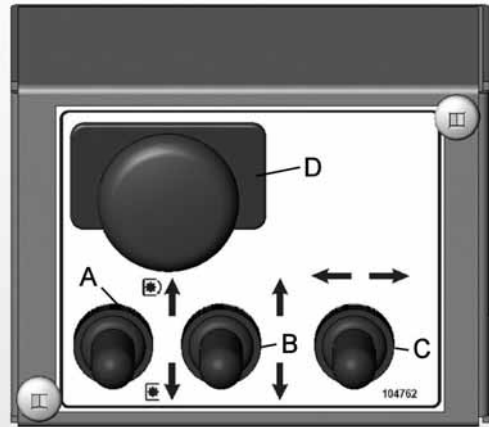

Connect the wires to the battery



# ASSEMBLY

**IMPORTANT:** The control box is equipped with a red emergency switch. Push down on this button if it becomes necessary to stop the engine quickly.

## **ENGINE CIRCUIT BREAKER (D) INSTALLATION: (EMERGENCY SWITCH WIRE):**

Find the wire (item 1) on the engine that supplies the engine's booster coil and disconnect it.

Assemble the connector (item 2) on the control box wire to the connector (item 3) on the engine wire (item 1).

Assemble the connector (item 5) on control box wire to the connector (item 4) on the engine wire (item 1).

**NOTE:** The emergency switch must be pulled out to start the engine of the snowblower.

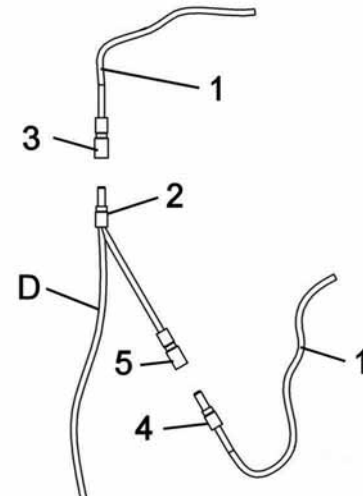
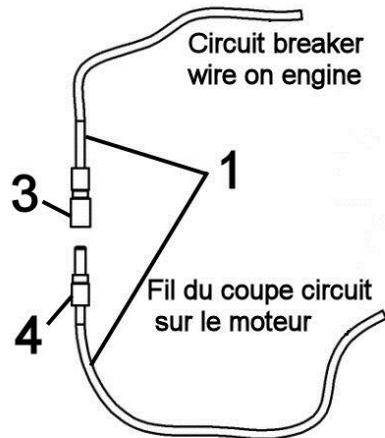

Install engine circuit breaker

Connect the red wire to the vehicle's positive battery post (item 1) and the black wire to the negative battery post (item 2).

Tie the wires to the vehicle with the nylon tie wraps so they do not get in the way.

**NOTE:** These wires will stay attached to the vehicle.

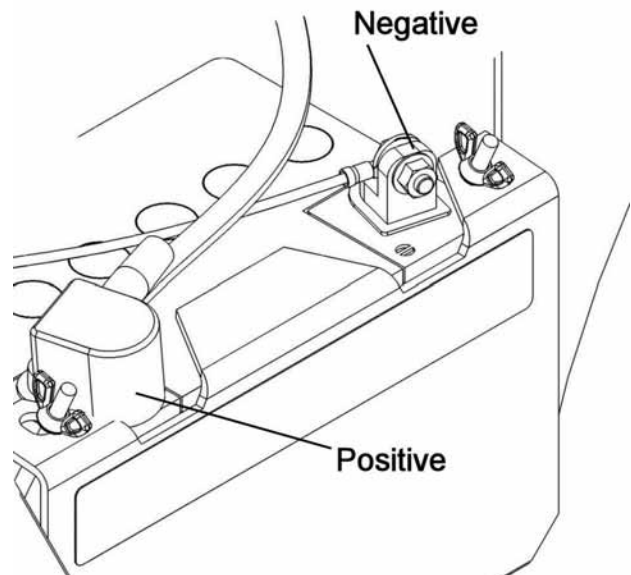

# ASSEMBLY

## IMPORTANT:

Take the time to familiarize yourself with the location of the switches and with their use.

**NOTE: If the switches don't match the right controls, reconnect the connectors with the right motors.**

Pay particular attention to the switch for the belt tensioner (item 4). This switch must be held in position for a few seconds in order to activate or deactivate the lever of the belt tensioner.

Make sure that the action is complete when you engage or disengage the snowblower.

## DANGER:

**It is the responsibility of the person who installs the engine and the controls to make sure that the engaging system works well and that the snowblower disengages effectively at all times. It is imperative to make the necessary adjustments if applicable.**

Identification of the switches:

1. Emergency switch. **(Pull out to start)**
2. Switch for the chute
3. Switch for the deflector
4. Switch for the belt tensioner.

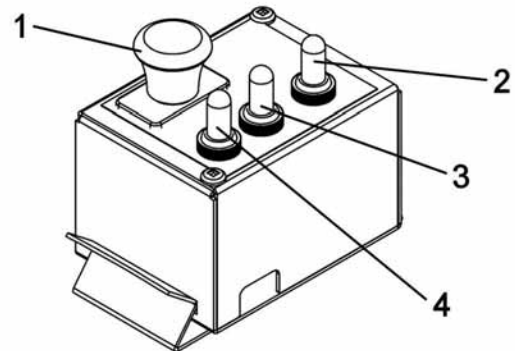

Identify the controls.

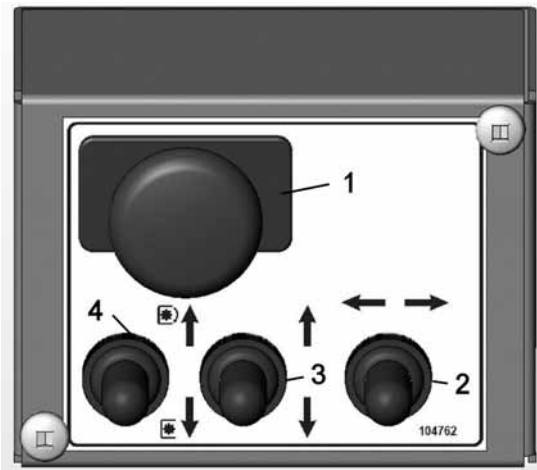

Turn the chute to its maximum towards the right.

Secure the wire of the motor for the deflector with a couple of tie wraps (item 1 & 2) as shown.

Secure the other wires with a few tie wraps (items 3, 4 & 5) as shown.

Be sure to leave enough wire length to be able to turn the chute freely.

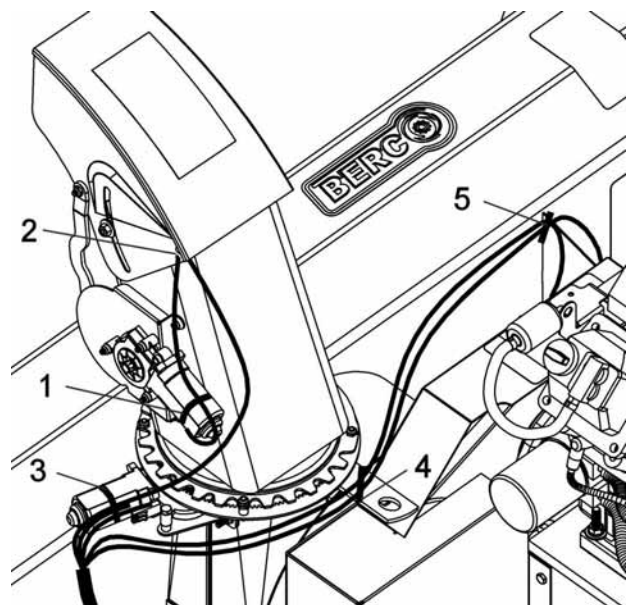

Secure wires on the motors

# ASSEMBLY

## STEP 6 FINAL ADJUSTMENTS



### DANGER



Never let the snowblower motor run without the belt guard in place.



### WARNING



#### TO PREVENT INJURIES:

Start the engine, engage and disengage the clutch to be sure it functions normally.

Make sure the emergency switch is working perfectly. Make sure all the controls are working well.

Adjust the idler pulley (item 2) as follows:

After installing the belt, you may run the engine without the belt guard, but only for the time needed to verify the belt alignment. Do not leave the snowblower without supervision.

**Neither you or anyone must approach the moving parts.**

Observe and familiarize yourself with the action time required to engage and disengage the snowblower. Then make sure that the belt is well aligned, especially on the idler pulley.

If necessary, you can add or remove a flat washer for final adjustment on the idler pulley (item 2).

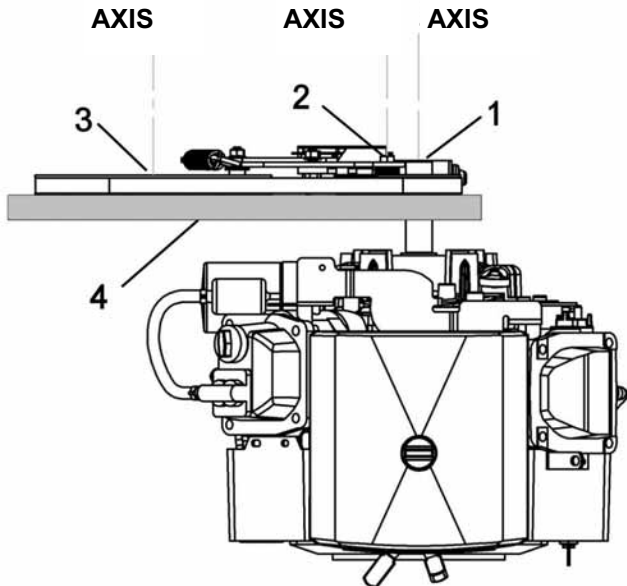

Figure 1

Top view of snowblower. All the pulleys are aligned and the engine is well installed.

Make sure the belt guide (item 2) is installed in the appropriate hole on the belt guard (item 3) according to the diameter of the engine shaft used. The hole on the right hand is for the 1" shaft and the hole on left hand is for the 1 1/8" shaft (sitting on the vehicle).

Insert a flange nut 5/16" (item 1) on the hex bolt 5/16" x 2 3/4" (item 2) as shown. Install the assembled bolt in the belt guard and secure with the other flange nut 5/16" (item 4).

**IMPORTANT:** make sure the belt does not rub on the belt guide when the belt is engaged.

#### **DANGER:**

It is the responsibility of the person who installs the engine and the controls to make sure that the engaging system works well and that the snowblower disengages effectively at all times. It is imperative to make the necessary adjustments if applicable.

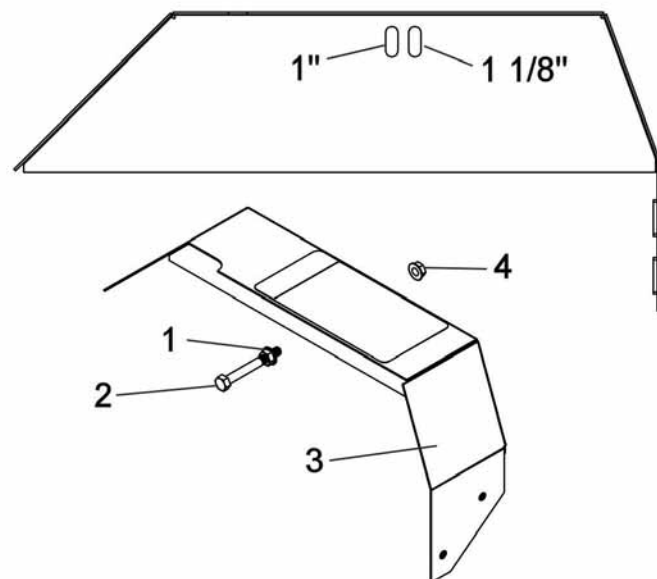

Install belt guard

# ASSEMBLY

Install the belt guard (item 1) and secure in place with three hex bolts 1/4" x 1/2" (item 2).

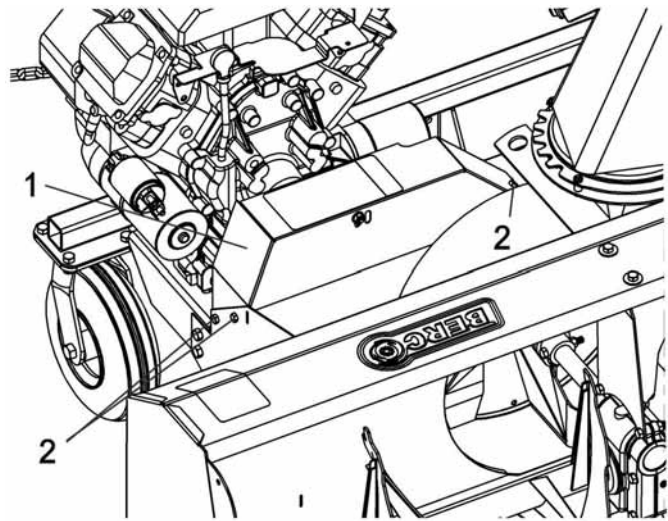

Install belt guard

## **VERIFY SKID SHOE ADJUSTMENT:**

**LEVEL PAVED SURFACE:** Adjust skid shoes to allow 3/16" to 1/4" clearance (A) between cutting edge and surface.

**UNEVEN OR GRAVEL SURFACE:** Adjust skid shoes to allow 1/2" to 5/8" clearance (A) between cutting edge and surface.

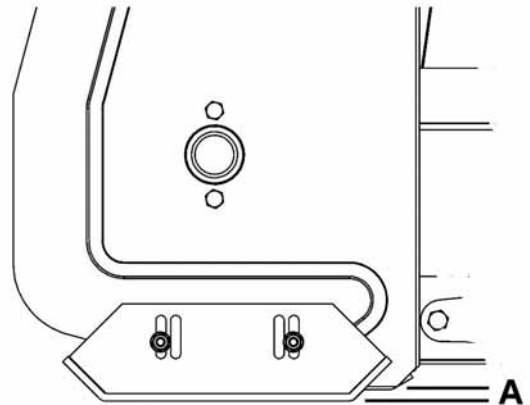

Adjust skid shoes

## OPERATION



### WARNING



Read the vehicle's owner's manual carefully. Be thoroughly familiar with the controls & proper use of the attachment. Know how to stop the unit & disengage the controls quickly.



### WARNING



- Do not attempt to clear plugged chute, auger or fan of snow while the snowblower's engine is running.
- Disengage snowblower.
- Lower snowblower onto ground.
- Set the parking brake.
- Stop engine, remove the ignition key, disconnect the wire from spark plug(s) and keep away from spark plug(s) to prevent accidental starting.
- Make sure all moving parts have stopped.
- Do not use hand to unplug chute.
- Use a 36" (924 mm.) minimum length stick or board.



### WARNING



**TO PREVENT INJURIES AND FOR MORE TRACTION WHEN USING SNOWBLOWER:**

- Do not drive faster than 3 km/hr (2 m/hr) with snowblower on the ground.
- Do not drive faster than 10 km/hr (6 m/hr) with the snowblower in raised position.
- Do not operate on a slope greater than 10°.
- Vehicle manufacturer approved tire chains are required.

### OPERATING THE SNOWBLOWER

- a) Make sure the snowblower is clear of snow before engaging the clutch.
- b) Make sure that the auger and impeller operate freely.
- c) Start the snowblower engine.
- d) Before engaging the snowblower drive, always have the engine running at max R.P.M.
- e) Operate the snowblower at maximum engine R.P.M.

**IMPORTANT: USE FULL ENGINE R.P.M. WHEN REMOVING WET, STICKY SNOW. LOW R.P.M. POWER WILL TEND TO PLUG THE CHUTE.**

### ELECTRICAL CONTROLS

See installation of the control box in order to identify the controls.

### RAISING AND LOWERING THE SNOWBLOWER:

Use the winch switch control to raise and lower the snowblower.

**IMPORTANT:** There is no lift stopper. Make sure there is no interference between the snowblower engine and the vehicle when lifting the snowblower.

### **EMERGENCY SWITCH:**

Push down on the emergency button to stop the engine.

**IMPORTANT:** The emergency button has to be pulled out in order to start the snowblower engine.

### REMOVING SNOW

When removing snow, do not use the snowblower as a dozer blade to push snow. Allow snowblower to ingest snow at its own speed. If the speed of your A.T.V. is too fast, the snowblower may become overloaded and plug. .

### CLEARING A CLOGGED DISCHARGE CHUTE:

Hand contact with the rotating impeller inside the discharge chute is the most common cause of injury associated with snowblowers. Never use your hand to clean out the discharge chute.

#### **To clear the chute:**

1. Lower snowblower to the ground and set parking brake.
2. SHUT THE ENGINE OFF & REMOVE KEY!
3. Wait 10 seconds to be sure the **all moving parts** such as the impeller blades have stopped moving.
4. Disconnect wire from the spark plug(s) and keep wire away to prevent accidental starting.
5. Always use a clean-out tool of at least 36" in length, **NEVER YOUR HANDS.**

# MAINTENANCE & DISMOUNTING



## WARNING



### TO PREVENT INJURIES:

Stop the snowblower motor.  
Apply parking brakes.  
Remove the ignition key.  
Disconnect the wire from the spark plug(s) and keep away from spark plug(s) to prevent accidental starting.

## MAINTENANCE

- Check mounting bolts at frequent intervals for proper tightness in order to prevent costly repairs. Make sure your snowblower is in safe working condition.
- Provide adequate blocking before working under the snowblower when in raised position.

## ADJUSTMENTS

### SKID SHOE ADJUSTMENT:

Level Paved Surface: Adjust skid shoes to allow 3/16" to 1/4" clearance between cutting edge and surface.

Uneven or Gravel Surface: Adjust skid shoes to allow 1/2" to 5/8" clearance between cutting edge and surface.

## LUBRICATION

Grease the wheel axles, the fork pivots and the hub on the double pulleys after every 4 hours of use.

Apply oil at all pivot points.

Drive Chains: Lubricate with chain saw chain lubricant every four hours of operation and at the end of each operation.

Chute Rotation System: Oil chute base, rotation worm every eight hours of operation.

## CUTTING EDGE MAINTENANCE

Verify from time to time the wearing on the cutting edge to make sure you do not wear out the base of the snowblower's chasis. This cutting edge is reversible. Unscrew the bolts and turn the cutting edge, reinstall and tighten the bolts securely.

## AUGER AND FAN SHEAR BOLT REPLACEMENT

The shear bolts are to be considered a preventive measure and not an assured protection. Operator vigilance is required. Thoroughly inspect the areas where the snowblower is to be used and remove all foreign objects.

## SNOWBLOWER PULLEY REPLACEMENT or ALIGNMENT:

Clean the parts before aligning or replacing the pulley. Apply some "Lock Tite" 2760 on the key and the set screws. Tighten firmly.

To avoid damage to the snowblower:

Use only the original shear bolts (grooved bolts).

#104000 in bags of 10 for the augers.

#103999 in bags of 10 for the fan.

The use of any other shear bolt will not insure any protection and may void the warranty.

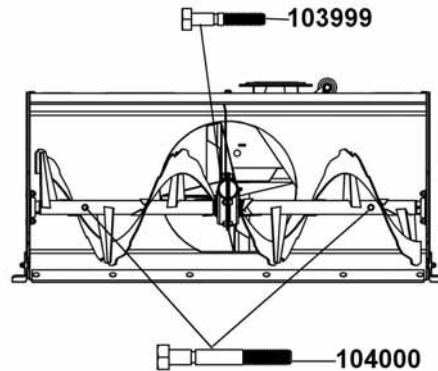

## DISMOUNTING

- Select a level surface, set parking brake, stop the engine, and remove the ignition key to prevent accidental starting.
- Lower the accessory to the ground
- Unhook the turnbuckles from the front of the vehicle, (Tip: slacken one of the turnbuckles in order to keep the adjustment), the hook from the winch and the hitch from the rear of the vehicle.
- Remove the control box (item 1) from the support (item 2). Disconnect the wires (item 3) and place the box on the accessory.
- Remove the vehicle.

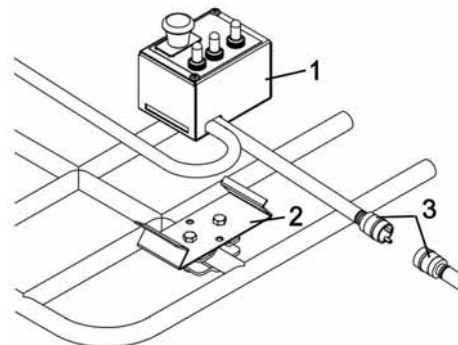

## STORAGE

- Clean snowblower and subframe thoroughly and repaint all parts from which paint has worn.
- List the replacement parts that will be needed to be replaced before the next season.
- Follow the instructions in the Lubrication section.
- Concerning the snowblower engine, follow the instructions in the engine owner's manual.
- Store the snowblower and the subframe in a dry place.

# BELT REPLACEMENT



## CAUTION



Never use the snowblower without the belt guard.

### **BELT REPLACEMENT:**

For belt part number, refer to parts breakdown section for parts identification.

- Remove the belt guard (item 1) by removing the three hex bolts  $1/4" \times 1/2"$  (item 2).
- Remove the tension from the belt by pushing on the switch for the belt tensioner.
- Remove the old belt from the engine pulley (item 3).
- Activate the switch for the electric motor for the belt tensioner to release the brake (item 4).

- After installing the belt, you may run the engine without the belt guard but only to verify the belt alignment. Do not leave the snowblower without supervision. Neither you or anyone else must approach the moving parts. Engage and disengage the snowblower to verify if the belt is well aligned, especially on the idler pulley (item 5).

**Make sure to hold the switch long enough so that the pulley sits well on the belts.**

If necessary, you can add or remove a flat washer on the idler pulley for final adjustments.

- Reinstall the belt guard.

**IMPORTANT:** make sure the belt does not rub on the belt guide (item 6) when the belt is engaged.

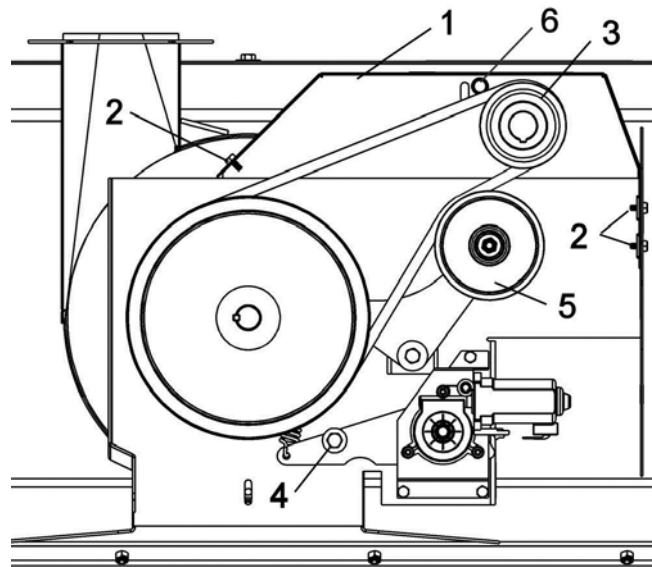

Belt replacement

## TROUBLESHOOTING

(For identification, see the parts breakdown)

PROBLEM	POSSIBLE CAUSES	CORRECTIVE ACTION
Snowblower vibrates or is abnormally noisy.	Damaged pulley.	Replace pulley.
	Damaged bearing.	Replace bearing.
	Damaged fan or sections of auger.	Dismount & repair or replace fan.
Auger stopped turning.	Shear bolt broken.	Replace shear bolt. Also see "Maintenance" section.
	Chain broken or connecting link unlocked.	Remove chain guard. Inspect and repair if needed.
Snowblower stopped turning.	The belts are damaged or snapped.	Check & replace damaged belts.
Belt is worn at a specific point.	Snowblower was engaged when already plugged.	Make sure auger & fan are not plugged or frozen before engaging snowblower.
	Lack of tension on the belt.	Replace the tension spring if it has lost its efficiency.
Belt showing premature wear.	Spring stretched.	Check spring. Replace if stretched.
	Engine and pulleys are misaligned	Realign the engine and pulleys.
Chute rotation is difficult.	Dirt or ice may be underneath chute.	Clean the base of chute & the rotation ring. Lubricate chute inside & out and the rotation worm.
The chute plugs easily.	Snowblower engine is turning too slowly.	Always have engine at full R.P.M. when using the snowblower.
	Advancing too quickly with vehicle.	Reduce speed. Allow snowblower to ingest snow at its own speed.
Snowblower digs into ground.	Ground is not frozen or too soft.	Adjust skid shoes lower so they may better support the snowblower.
Snowblower does not raise evenly.	Tire pressure uneven from one side to another.	Verify and adjust tire pressure: 50 p.s.i.
The engine does not start	The emergency button is pushed down.	The emergency button must be pulled up to start the engine of the snowblower.
	Other reasons	See the engine's owner's manual.
Electric motor does not work	Overheating of the motor	These motors are equipped with an internal protector. Wait 10 minutes before using.



# TORQUE SPECIFICATION TABLE

## GENERAL TORQUE SPECIFICATION TABLE USE THE FOLLOWING TORQUES WHEN SPECIAL TORQUES ARE NOT GIVEN

NOTE: These values apply to fasteners as received from supplier, dry or when lubricated with normal oil. They do not apply if special graphited or moly disulphide greases or other extreme pressure lubricants are used. This applies to both UNF and UNC threads.

SEE Grade No.		2				5				8 *			
BOLT HEAD IDENTIFICATION MARKS AS PER GRADE NOTE MANUFACTURING MARKS WILL VARY		TORQUE				TORQUE				TORQUE			
BOLT SIZE		POUNDS FEET		NEWTON-METERS		POUNDS FEET		NEWTON-METERS		POUNDS FEET		NEWTON-METERS	
Inches	Millimetre	Min.	Max.	Min.	Max.	Min.	Max.	Min.	Max.	Min.	Max.	Min.	Max.
1/4"	6.35	5	6	6.8	8.13	9	11	12.2	14.9	12	15	16.3	30.3
5/16"	7.94	10	12	13.6	16.3	17	20.5	23.1	27.8	24	29	32.5	39.3
3/8"	9.53	20	23	27.1	31.2	35	42	47.5	57	45	54	61	73.2
7/16"	11.11	30	35	40.7	47.4	54	64	73.2	86.8	70	84	94.9	113.9
1/2"	12.7	45	52	61	70.5	80	96	108.5	130.2	110	132	149.2	179
9/16"	14.29	65	75	88.1	101.6	110	132	149.2	179	160	192	217	260.4
5/8"	15.88	95	105	128.7	142.3	150	180	203.4	244.1	220	264	298.3	358
3/4"	19.05	150	185	203.3	250.7	270	324	366.1	439.3	380	456	515.3	618.3
7/8"	22.23	160	200	216.8	271	400	480	542.4	650.9	600	720	813.6	976.3
1"	25.4	250	300	338.8	406.5	580	696	786.5	943.8	900	1080	1220.4	1464.5

\*Thick nuts must be used with grade 8 bolts

METRIC BOLT TORQUE SPECIFICATIONS							
Size Screw	Grade No.	Pitch (mm)	COARSE THREAD		FINE THREAD		
			Pounds Feet	Newton-Meters	Pitch (mm)	Pounds Feet	Newton-Meters
M6	4T	1.00	3.6 - 5.8	4.9 - 7.9	-	-	-
	7T		5.8 - 9.4	7.9 - 12.7		-	-
	8T		7.2 - 10	9.8 - 13.6		-	-
M8	4T	1.25	7.2 - 14	9.8 - 19	1.00	12 - 17	16.3 - 23
	7T		17 - 22	23 - 29.8		19 - 27	25.7 - 36.6
	8T		20 - 26	27.1 - 35.2		22 - 31	29.8 - 42
M10	4T	1.50	20 - 25	27.1 - 33.9	1.25	20 - 29	27.1 - 39.3
	7T		34 - 40	46.1 - 54.2		35 - 47	47.4 - 63.7
	8T		38 - 46	51.5 - 62.3		40 - 52	54.2 - 70.5
M12	4T	1.75	28 - 34	37.9 - 46.1	1.25	31 - 41	42 - 55.6
	7T		51 - 59	69.1 - 79.9		56 - 68	75.9 - 92.1
	8T		57 - 66	77.2 - 89.4		62 - 75	84 - 101.6
M14	4T	2.00	49 - 56	66.4 - 75.9	1.50	52 - 64	70.5 - 86.7
	7T		81 - 93	109.8 - 126		90 - 106	122 - 143.6
	8T		96 - 109	130.1 - 147.7		107 - 124	145 - 168
M16	4T	2.00	67 - 77	90.8 - 104.3	1.50	69 - 83	93.5 - 112.5
	7T		116 - 130	157.2 - 176.2		120 - 138	162.6 - 187
	8T		129 - 145	174.8 - 196.5		140 - 158	189.7 - 214.1
M18	4T	2.00	88 - 100	119.2 - 136	1.50	100 - 117	136 - 158.5
	7T		150 - 168	203.3 - 227.6		177 - 199	239.8 - 269.6
	8T		175 - 194	237.1 - 262.9		202 - 231	273.7 - 313
M20	4T	2.50	108 - 130	146.3 - 176.2	1.50	132 - 150	178.9 - 203.3
	7T		186 - 205	252 - 277.8		206 - 242	279.1 - 327.9
	8T		213 - 249	288.6 - 337.4		246 - 289	333.3 - 391.6

**PARTS BREAKDOWN / NOMENCLATURE DES PIÈCES  
ROTATION SYSTEM WITH CHUTE  
SYSTÈME DE ROTATION AVEC GOULOTTE**

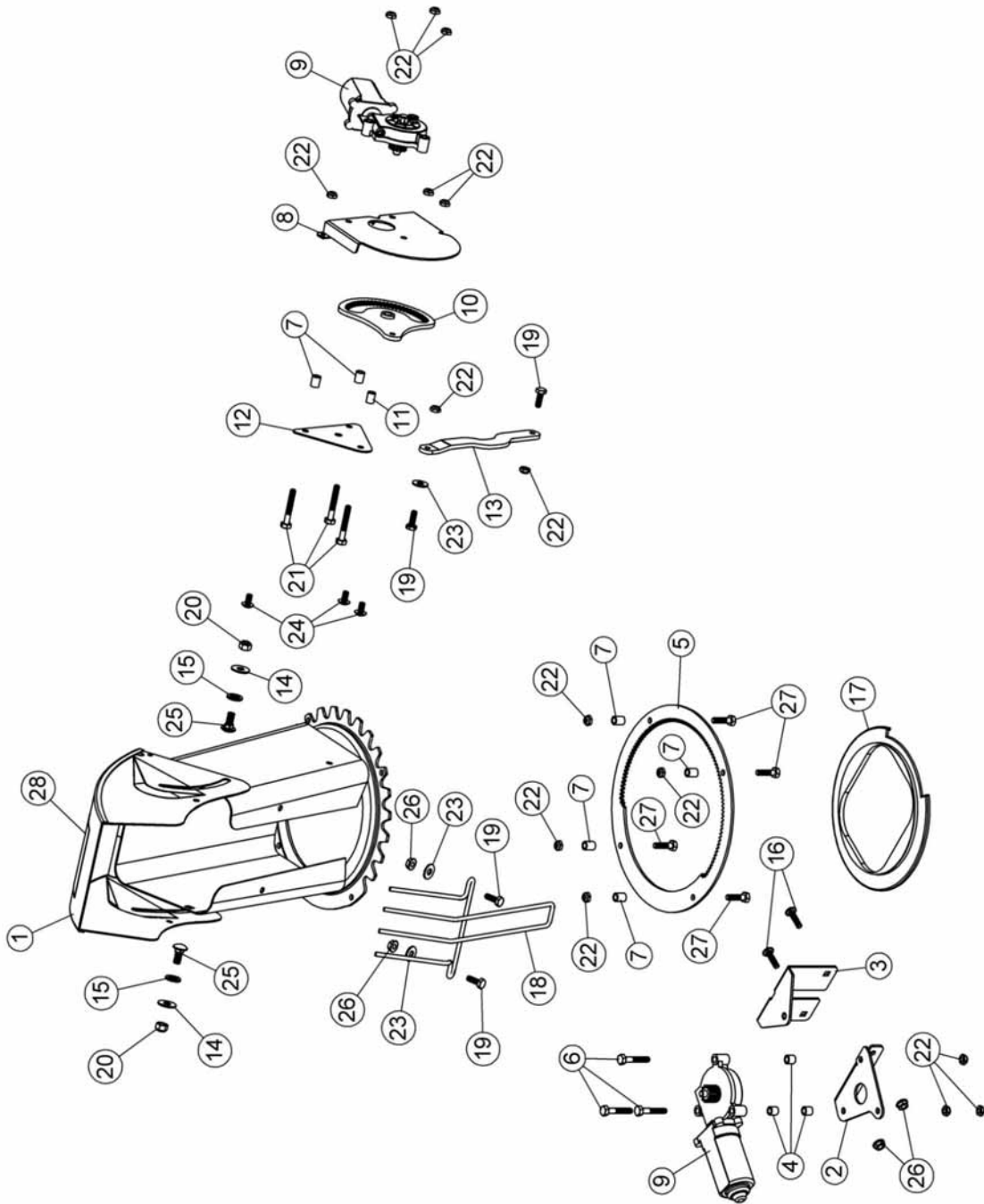

## PARTS LIST / LISTE DES PIÈCES

Ref. Réf.	English description	Description française	Qty. Qté.	Part # Pièce #
1	Chute	Goulotte	1	103936
2	Bracket	Support	1	103971
3	Reinforcement plate	Plaque de renforcement	1	103972
4	Spacer	Espaceur	3	103368
5	Rotation ring	Anneau de rotation	1	103974
6	Hex. bolt 1/4" n.c. x 1 1/2"	Boulon hex. 1/4" n.c. x 1 1/2"	3	O/L
7	Spacer	Espaceur	6	103361
8	Bracket	Support	1	103375
9	Electric motor	Moteur électrique	2	103378
10	Lever	Levier	1	103365
11	Oil lite bushing	Coussinet imprégné d'huile	1	103362
12	Plate	Plaque	1	103363
13	Arm	Bras	1	103364
14	Nylon flat washer 11/32"	Rondelle plate de nylon 11/32"	2	102009
15	Nylon flat washer 7/16"	Rondelle plate de nylon 7/16"	2	102011
16	Carriage bolt 1/4" n.c. x 1"	Boulon à carrosserie 1/4" n.c. x 1"	2	O/L
17	Rotation ring	Anneau de rotation	1	103943
18	Hand guard	Fourche protectrice	1	102012
19	Hex. bolt 1/4" n.c. x 3/4"	Boulon hex. 1/4" n.c. x 3/4"	4	O/L
20	Nylon insert lock nut 5/16" n.c.	Écrou à garniture de nylon 5/16" n.c.	2	O/L
21	Hex. bolt 1/4" n.c. x 1 3/4"	Boulon hex. 1/4" n.c. x 1 3/4"	3	O/L
22	Nylon insert lock nut 1/4" n.c. (thin)	Écrou à garniture de nylon 1/4" n.c.(mince)	15	O/L
23	Flat washer 5/16" hole	Rondelle plate 5/16" trou	3	O/L
24	Machine screw T.H. 1/4" n.c. x 1/2"	Vis mécanique T.H. 1/4" n.c. x 1/2"	3	O/L
25	Carriage bolt 5/16" n.c. x 3/4"	Boulon à carrosserie 5/16" n.c. x 3/4"	2	O/L
26	Flange nut 1/4" n.c.	Écrou à bride 1/4" n.c.	4	O/L
27	Hex. bolt 1/4" n.c. x 1"	Boulon hex. 1/4" n.c. x 1"	4	O/L
28	Danger decal	Décalque danger	1	102127

O/L= Obtain locally / Obtenir localement

# PARTS BREAKDOWN / NOMENCLATURE DES PIÈCES SUBFRAME ASSEMBLY/ SOUS-CHÂSSIS ASSEMBLÉ

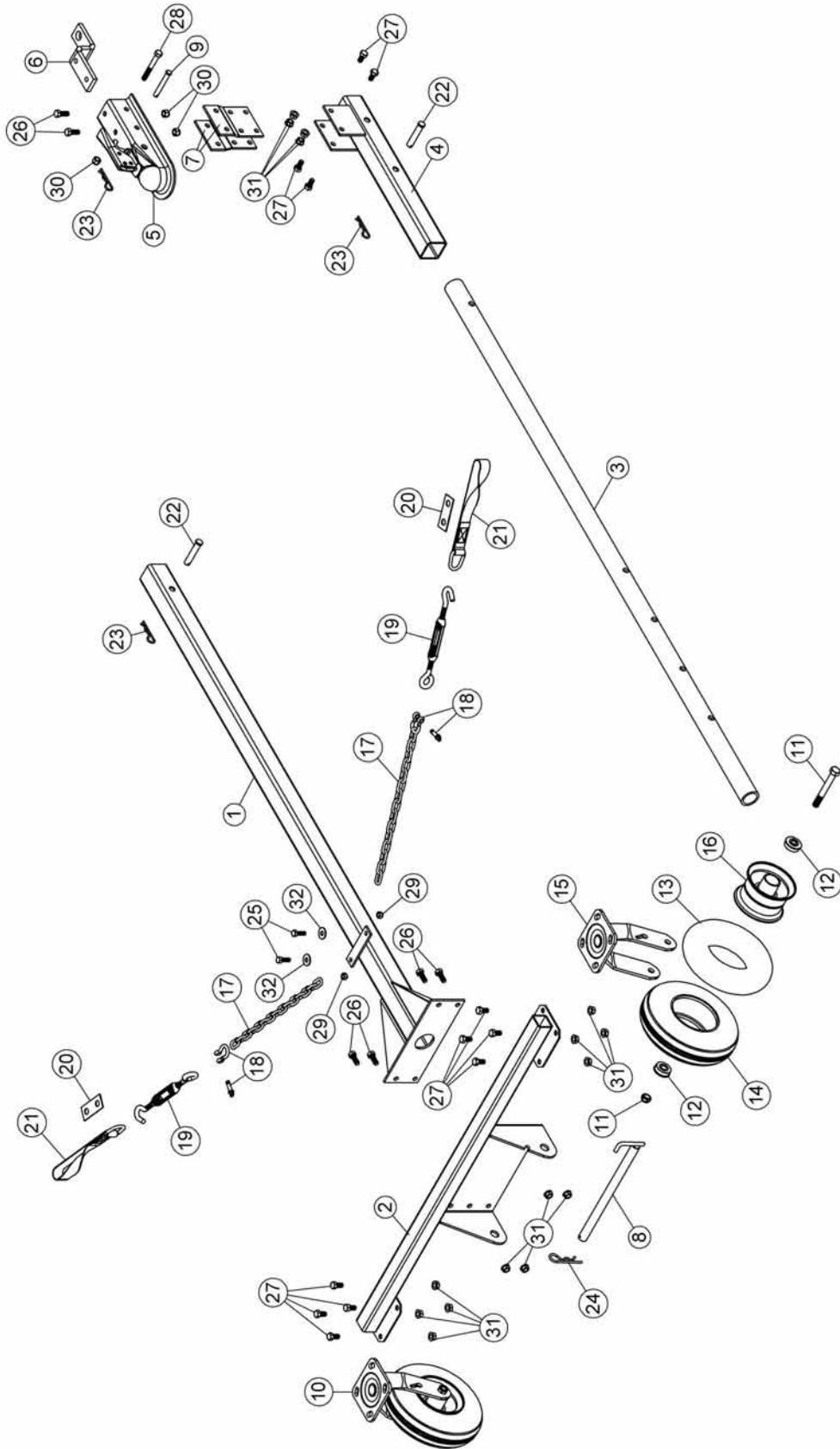

## PARTS LIST / LISTE DES PIÈCES

Ref. Réf.	English description	Description française	Qty. Qté.	Part # Pièce #
1	Subframe	Sous-châssis	1	104769
2	Wheel support	Support de roue	1	104770
3	Adjustment tube	Tube d'ajustement	1	104637
4	Lock washer 3/8"	Rondelle de blocage 3/8"	4	O/L
5	Hex. nut 3/8" n.c.	Écrou hex. 3/8" n.c.	4	O/L
6	Caster wheel assembly	Roue pivotante assemblée	2	104779
7	Flange nut 3/8" n.c.	Écrou à bride 3/8" n.c.	12	O/L
8	Hex. bolt 3/8" n.c. x 1"	Boulon hex. 3/8" n.c. x 1"	6	O/L
9	Hex. bolt 3/8" n.c. x 3/4"	Boulon hex. 3/8" n.c. x 3/4"	12	O/L
10	Axle bolt & nut	Boulon essieu & écrou	1	104778
11	Ball bearing	Roulement à billes	2	102688
12	Inner tube 250-4	Chambre à air 250-4	1	102675
13	Tire 280/250-4	Pneu 280/250-4	1	102674
14	Fork assembly	Fourche assemblée	1	104777
15	Rim & bearing	Jante & roulement	1	104793
16	Chain	Chaîne	2	104633
17	Shackle Ptd Z	Clevis Pqé Z	2	102343
18	Turnbuckle	Tendeur	2	104634
19	Bracket	Fixation	2	104632
20	Lift strap	Sangle de relevage	2	103613
21	Pin	Goupille	2	102189
22	Hair pin 3mm	Goupille à ressort 3mm	3	102617
23	Hair pin 4mm	Goupille à ressort 4mm	1	102054
24	Pin	Goupille	1	104759
25	Hex. bolt 5/16" n.c. x 1"	Boulon hex. 5/16" n.c. x 1"	2	O/L
26	Flat washer 3/8" hole	Rondelle plate 3/8" trou	2	O/L
27	Nylon insert lock nut 5/16" n.c.	Écrou à garniture de nylon 5/16" n.c.	2	O/L
28	Hitch support	Support d'attache	1	104638
29	Hitch support	Support d'attache	2	104641
30	Hitch	Attache	1	104639
31	Hitch ball support	Support de boule d'attelage	1	104640
32	Nylon insert lock nut 3/8" n.c.	Écrou à garniture de nylon 3/8" n.c.	3	O/L
33	Pin	Goupille	1	104642
34	Hex. bolt 3/8" n.c. x 3"	Boulon hex. 3/8" n.c. x 3"	1	O/L

O/L= Obtain locally / Obtenir localement

# PARTS BREAKDOWN / NOMENCLATURE DES PIÈCES SNOWBLOWER / SOUFFLEUSE

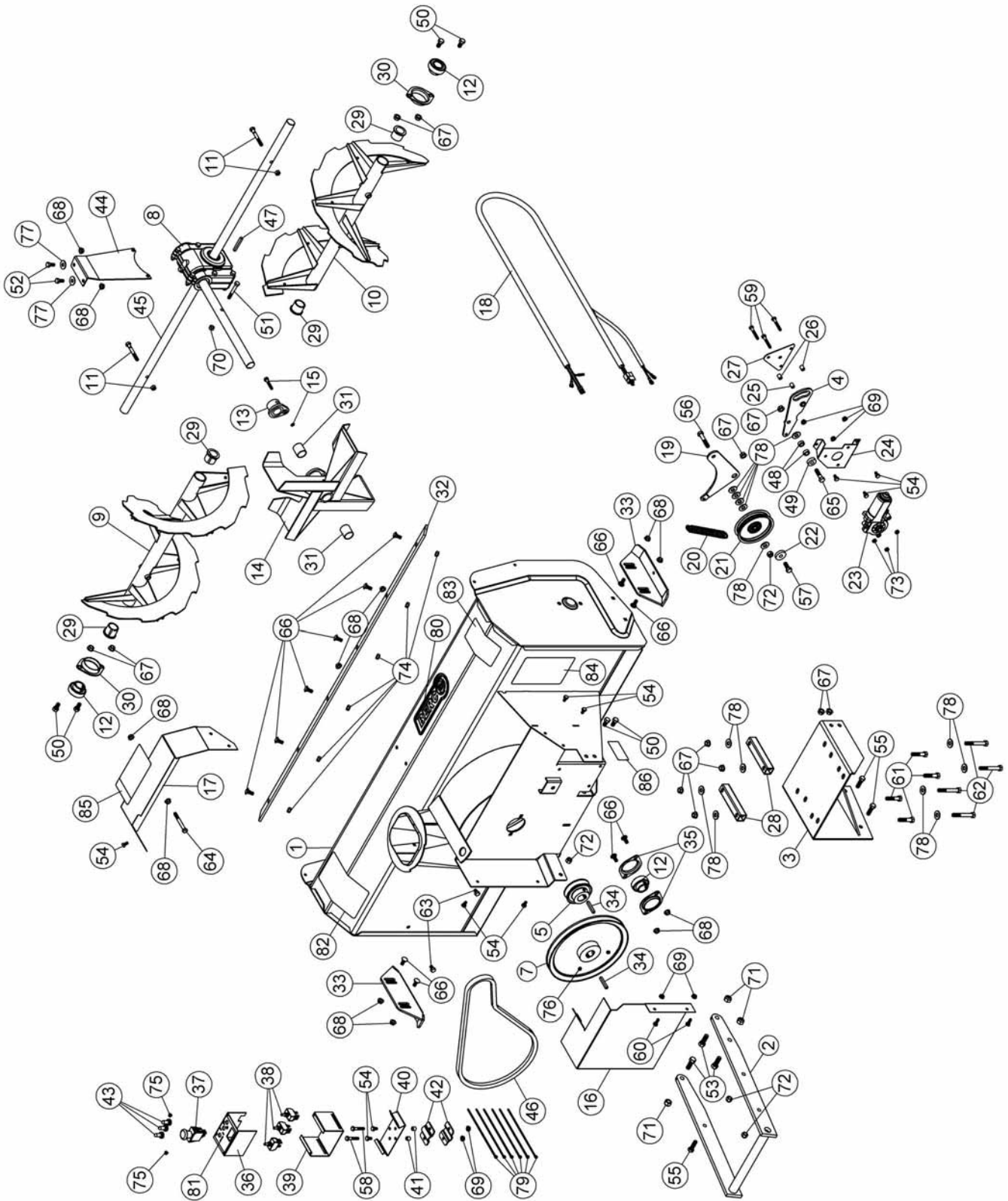

## PARTS LIST / LISTE DES PIÈCES

Ref. Réf.	English description	Description française	Qty. Qté.	Part # Pièce #
1	Frame 48"	Châssis 48"	1	104966
2	Hitch	Attache	1	104781
3	Engine support	Support-moteur	1	104782
4	Lever	Levier	1	104783
5	Pulley 3.15" with set screw	Poulie 3.15" avec vis pression	1	104833
6	Pulley 3.55" with set screw	Poulie 3.55" avec vis pression	1	104839
7	V pulley	Poulie en V	1	104774
8	Gear box left rotation	Boîte d'engrenage rotation gauche	1	104718
9	Auger 48" left	Vis 48" gauche	1	104765
10	Auger 48" right	Vis 48" droite	1	104766
11	Shear bolt / N.I.L.N. (auger) pkg-10	Boulon de séc. / É.G.N. (vis) pqt-10	2	104000
12	Bearing with set screw	Roulement à billes avec vis à pression	3	102755
13	Shear plate	Plaque de cisaillement	1	103933
14	Fan	Éventail	1	103932
15	Shear bolt / N.I.L.N. (fan) pkg-10	Boulon de séc./ É.G.N. (éven.) pqt-10	1	103999
16	Guard	Garde	1	104788
17	Belt guard	Garde-courroie	1	104789
18	Wire assembly	Fil assemblé	1	104764
19	Bender	Tendeur	1	104785
20	Spring	Ressort	1	102592
21	Flat pulley	Poulie plate	1	102300
22	Flange washer	Rondelle à bride	1	102081
23	Electric motor	Moteur électrique	1	103378
24	Bracket	Fixation	1	104786
25	Oil lite bushing	Coussinet imprégné d'huile	1	103362
26	Spacer	Espaceur	2	103361
27	Plate	Plaque	1	103363
28	Shim	Cale	2	104787

## PARTS LIST / LISTE DES PIÈCES

Ref. Réf.	English description	Description française	Qty. Qté.	Part # Pièce #
29	Rotation bushing	Coussinet de rotation	4	103946
30	Flangette	Flangette	2	102680
31	Oil lite bushing	Coussinet imprégné d'huile	2	102784
32	Cutting edge 48"	Racloir 48"	1	103187
33	Skid shoe	Patin	2	103188
34	Key 1/4" x 1/4" x 1 3/4"	Clé 1/4" x 1/4" x 1 3/4"	2	102327
35	Flangette	Flangette	2	102213
36	Box cover	Couvercle de la boîte	1	104758
37	Emergency switch	Interrupteur d'urgence	1	104807
38	Switch	Commutateur	3	103381
39	Box	Boîte	1	104757
40	Box support	Support de la boîte	1	104756
41	Spacer	Espaceur	2	103368
42	Support bracket	Fixation du support	2	103068
43	Rubber boot	Capuchon de caoutchouc	3	103379
44	Gear box support	Support de boîte d'engrenage	1	104746
45	Shaft 48"	Arbre 48"	1	104721
46	V-belt, B-47	Courroie en V, B-47	1	104790
47	Key 1/4" x 1/4" x 2"	Clé 1/4" x 1/4" x 2"	1	102922
48	Sleeve	Douille	2	102322
49	Spacer	Espaceur	1	102241
50	Hex. bolt 3/8" n.c. x 3/4"	Boulon hex. 3/8" n.c. x 3/4"	6	O/L
51	Hex. bolt 5/16" n.c. x 2 1/4" GR8	Boulon hex. 5/16" n.c. x 2 1/4" GR8	1	O/L
52	Hex. bolt 5/16" n.c. x 3/4"	Boulon hex. 5/16" n.c. x 3/4"	2	O/L
53	Hex. bolt 7/16" n.c. x 1 1/4"	Boulon hex. 7/16" n.c. x 1 1/4"	3	O/L
54	Hex. bolt 1/4" n.c. x 1/2"	Boulon hex. 1/4" n.c. x 1/2"	10	O/L
55	Hex. bolt 3/8" n.c. x 1 1/4"	Boulon hex. 3/8" n.c. x 1 1/4"	3	O/L
56	Hex. bolt 3/8" n.c. x 2"	Boulon hex. 3/8" n.c. x 2"	1	O/L
57	Hex. bolt 3/8" n.c. x 1"	Boulon hex. 3/8" n.c. x 1"	1	O/L

O/L= Obtain locally / Obtenir localement



## PARTS LIST / LISTE DES PIÈCES

Ref. Réf.	English description	Description française	Qty. Qté.	Part # Pièce #
58	Hex. bolt 1/4" n.c. x 1 1/2"	Boulon hex. 1/4" n.c. x 1 1/2"	2	O/L
59	Hex. bolt 1/4" n.c. x 1 3/4"	Boulon hex. 1/4" n.c. x 1 3/4"	3	O/L
60	Hex. bolt 1/4" n.c. x 3/4"	Boulon hex. 1/4" n.c. x 3/4"	2	O/L
61	Hex. bolt 3/8" n.c. x 1 3/4"	Boulon hex. 3/8" n.c. x 1 3/4"	4	O/L
62	Hex. bolt 3/8" n.c. x 2 3/4"	Boulon hex. 3/8" n.c. x 2 3/4"	4	O/L
63	Hex. bolt 5/16" n.c. x 1/2"	Boulon hex. 5/16" n.c. x 1/2"	2	O/L
64	Hex. bolt 5/16" n.c. x 2 3/4"	Boulon hex. 5/16" n.c. x 2 3/4"	1	O/L
65	Hex. bolt 3/8" n.c. x 1 1/2"	Boulon hex. 3/8" n.c. x 1 1/2"	1	O/L
66	Carriage bolt 5/16" n.c. x 3/4"	Boulon à carrosserie 5/16" n.c. x 3/4"	12	O/L
67	Flange nut 3/8" n.c.	Écrou à bride 3/8" n.c.	12	O/L
68	Flange nut 5/16" n.c.	Écrou à bride 5/16" n.c.	12	O/L
69	Flange nut 1/4" n.c.	Écrou à bride 1/4" n.c.	7	O/L
70	Nylon insert lock nut 5/16" n.c.	Écrou à garniture de nylon 5/16" n.c.	1	O/L
71	Nylon insert lock nut 7/16" n.c.	Écrou à garniture de nylon 7/16" n.c.	3	O/L
72	Nylon insert lock nut 3/8" n.c.	Écrou à garniture de nylon 3/8" n.c.	4	O/L
73	Nylon insert lock nut 1/4" n.c. (thin)	Écrou à garniture de nylon 1/4" n.c.(mince)	3	O/L
74	Stover lock nut 5/16" n.c.	Écrou de blocage 5/16" n.c.	6	O/L
75	Metal screw pan head #8 x 1/4"	Vis à métal tête pan #8 x 1/4"	2	O/L
76	Hex. socket set screw 5/16" n.c. x 5/16"	Vis à pression hex. 5/16" n.c. x 5/16"	2	O/L
77	Flat washer 3/8" hole	Rondelle plate 3/8" trou	2	O/L
78	Flat washer 7/16" hole	Rondelle plate 7/16" trou	14	O/L
79	Tie wrap 8"	Attache de nylon 8"	6	O/L
80	Berco decal	Décalque Berco	1	102471
81	Control decal	Décalque de contrôle	1	104762
82	Warning decal	Décalque attention	1	102125
83	Danger decal	Décalque danger	1	102126
84	Shear bolt decal	Décalque boulon de sécurité	1	103951
85	Danger decal	Décalque danger	1	102128
86	Serial number	Numéro de série	1	REF

O/L= Obtain locally / Obtenir localement

## OPTIONS & ACCESSORIES



**#700269**  
**LIFT CONNECTION KIT**  
 Reduces the effort and the speed required by the winch to lift the accessory .



**#700260**  
**SNOW DRIFT CUTTER**  
 Slices through high snow drifts to facilitate and increase snow intake. Package of 2.

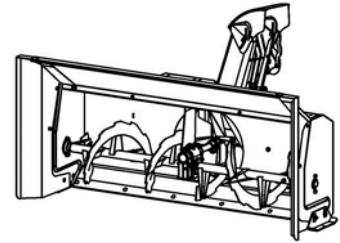

**#700461**  
**EXTENSION AND SIDE WIDENING ANGLES KIT**  
 Widens the snowblower to 60"

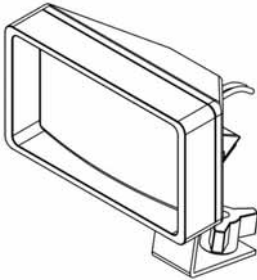

**#700456**  
**LIGHT KIT**  
 Better visibility for night time use

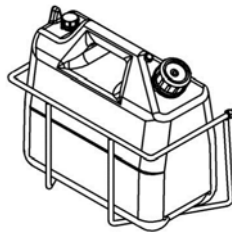

**#700462**  
**GAS TANK KIT**  
 Handy for easy re-fuelling

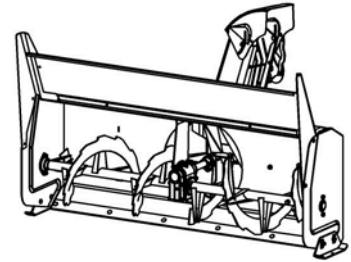

**#700473**  
**EXTENSION**  
 Adds 8" to the height of the snowblower  
**REQUIRES #700260**

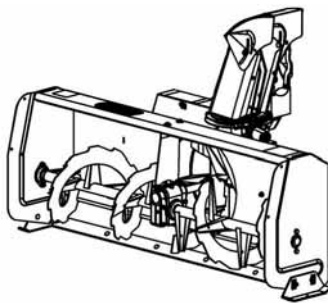

**#700460**  
**54" VERSATILE SNOWBLOWER**  
 For ATV or UV

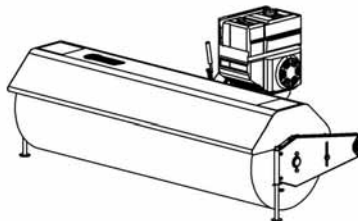

**#700448**  
**60" ROTARY BROOM**  
 For ATV or UV

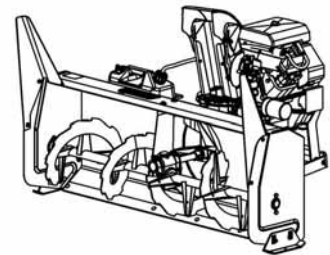

**#700360**  
**54" PRESTIGE SNOWBLOWER**  
 For ATV