



OWNER'S MANUAL

Model Number

Original Version

700512-4 EPA
700513-4 EPA

700512-4 66" Snowblower
700513-4 72" Snowblower

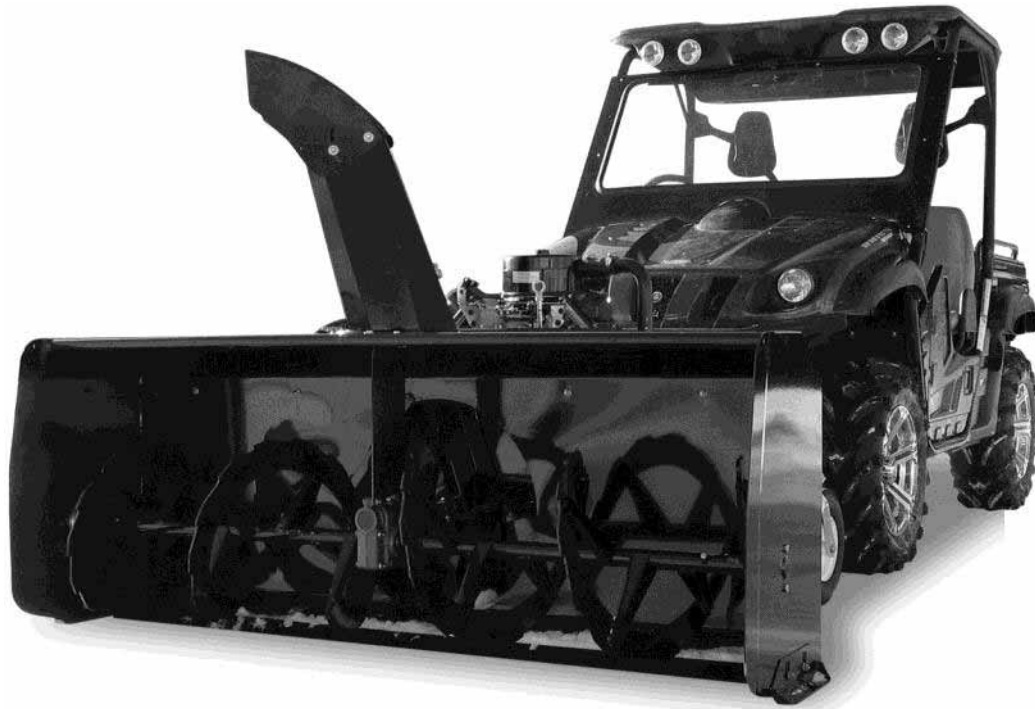

BERCO ***VANTAGE 66" & 72" Snowblower*** For ***OFF ROAD UTILITY VEHICLE***

* ASSEMBLY
* OPERATION

* REPAIR PARTS
* MAINTENANCE

CAUTION:

**READ & FOLLOW ALL SAFETY RULES & INSTRUCTIONS BEFORE
OPERATING YOUR EQUIPMENT**



LIMITED WARRANTY

Conditions and Products Covered:

BERCOMAC guarantees any part of the product or accessory manufactured by BERCOMAC and found in the reasonable judgment of BERCOMAC to be defective in material and or workmanship will be repaired or replaced by an authorized dealer without charge up to our maximum labor rates and pre-established times. For replacement parts only standard ground freight services are covered. This warranty extends to the original retail purchaser only and is not transferable to any subsequent purchasers. This warranty applies to the products bought and used in North America.

Warranty Period

(from date of the original retail purchase):

- Residential or semi-commercial use: 1 year
- Commercial, professional or rental use: 90 days

Exceptions Noted Below; the following items are guaranteed by the original manufacturer and have their own warranty, conditions and limited time:

- Tire Chains: 90 days
- Engines: Will vary as per the manufacturer
Please refer to the engine manufacturer's warranty statement included with the unit. BERCOMAC is not authorized to handle warranty adjustments on engines.

Items and Conditions NOT Covered:

This warranty does not cover the following:

- Pick-up or delivery charges or in-home services fees.
- Any damage or deterioration of the unit, parts and or finish of these due to normal use, wear and tear, or exposure.
- Cost of regular use or maintenance service or parts, such as gas, oil, lubricants, tune-up parts, and adjustments.
- Any part or accessory which has been altered, modified, misused, neglected, accidentally damaged or not properly installed, maintained, stored or repaired not in accordance with the instructions in the owner's manual.
- Repair due to normal wear and or any wear items include but are not limited to items such as shear pins, bolts, belts, winch cables, cutting edge, skid shoes etc.
- Expedited freight fee services for replacement parts.
- Shear bolts and shear pins are to be considered as a preventive measure not as an assured protection, any damages resulting from the lack of shear bolts breakage are not covered.
- Damages due to product being installed on vehicle other than stipulated in the owner's manual.

NOTE: All warranty work must be performed by an authorized dealer using original (manufacturer) replacement parts.

NOTE: Bercomac reserves the right to change or improve the design of any part or accessory without assuming any obligation to modify any product previously manufactured.

Instructions for Obtaining Warranty Services:

Contact dealer where equipment was purchased or any other authorized service dealer to arrange service at their dealership. Requests for warranty claims must be carried out through the same distribution network used to purchase the product. Don't forget to bring your proof of purchase (sales receipt) to the dealer.

Owner's Responsibilities:

Any defective equipment or part must be returned to an authorized dealer within the warranty period for repairs. In the event that defective merchandise must be returned to manufacturer for repairs, the dealer must first obtain a written authorization from either KIMPEX or BERCOMAC, freight fees are prepaid prior to the shipment. This warranty extends only to equipment operated under normal conditions. To validate a warranty claim, it is the user's responsibility to maintain and service the unit as specified in the owner's manual or to have the unit serviced at their dealer at their expense.

General Conditions:

The sole liability of BERCOMAC with respect to this warranty shall be strictly and exclusively repair and replacement as mentioned herein. BERCOMAC shall not have any liability for any other costs, loss or damage, including but not limited to, any incidental or consequential loss or damage.

Taking advantage of the warranty does not in any way extend the length or renewal of the warranty.

In particular, without being limited to, BERCOMAC shall have no liability or responsibility for:

- Travel time, overtime, after hours time or other extraordinary repair charges or relating to repairs and or replacements outside of normal business hours.
- Rental of like or similar replacement equipment during the period of any, repair or replacement work.
- Any communicating or travel charges.
- Loss or damage to person or property other than that covered by the terms of this warranty.
- Any claims for lost revenue, lost profit or any similar costs as a result of damage or repair.
- Attorney's fees.

BERCOMAC's responsibility in respect to claims is limited to making the required repairs or replacement without charge up to our maximum labor rates and pre-established times and no claim of breach of warranty shall be cause for cancellation or rescission of the contract of sale of any product or accessory. In no event shall recovery of any kind be greater than the amount of the purchase price of the product sold.

This warranty gives you specific legal rights. You may also have other rights, which vary from state to state.

TABLE OF CONTENTS

INTRODUCTION	2
SAFETY PRECAUTIONS	3
SAFETY DECALS	5
ASSEMBLY	
Tools Required	6
Snowblower Preparation	7
Vehicle Preparation	8
Preparing the Subframe	9
Installing on the Vehicle	11
Control Box Installation	13
Installing the Spring	15
OPERATION	
Snowblower Operation	16
Electrical Controls	16
Lifting and Lowering the Snowblower	16
Burnishing Procedure.....	16
Snowblowing Technique	17
Skid Shoe Adjustment	17
MAINTENANCE	
Engine Maintenance	18
Snowblower Maintenance	18
Pressure of the tires on the subframe.....	18
Clearing a Clogged Discharge Chute	18
Cutting Edge Maintenance	18
Lubrication	18
Auger and Fan Shear Bolt Replacement	19
Belt Replacement	20
Replacing the Augers, Fan and / or Gear Box	21
MAINTENANCE & DISMOUNTING	22
TROUBLESHOOTING	23
PARTS BREAKDOWN AND PARTS LIST	
Vantage Snowblower 66"	25
Vantage Snowblower 72"	35
Subframe	45
Honda Engine 24hp	47
Kohler Engine 22.5hp	50
Kohler Engine 25hp	52
Exploded view parts	54
TORQUE SPECIFICATION TABLE	56
OPTIONS & ACCESSORIES	57

INTRODUCTION

TO THE PURCHASER

This new accessory was carefully designed to give years of dependable service. This manual has been provided to assist in the safe operation and servicing of your attachment.

NOTE: All photographs and illustrations in the manual may not necessarily depict the actual models or attachment, but are intended for reference only and are based on the latest product information available at the time of publication.

Familiarize yourself fully with the safety recommendations and operating procedures before putting the machine to use. Carefully read, understand and follow these recommendations and insist that they be followed by those who will use this attachment.



THIS SAFETY ALERT SYMBOL IDENTIFIES AN IMPORTANT SAFETY MESSAGE IN THIS MANUAL THAT HELPS YOU AND OTHERS AVOID PERSONAL INJURY OR EVEN DEATH. DANGER, WARNING, AND CAUTION ARE SIGNAL WORDS USED TO IDENTIFY THE LEVEL OF HAZARD. HOWEVER, REGARDLESS OF THE HAZARD, BE EXTREMELY CAREFUL.

DANGER: Signals an extreme hazard that will cause serious injury or death if recommended precautions are not followed.

WARNING: Signals a hazard that may cause serious injury or death if the recommended precautions are not followed.

CAUTION: Signals a hazard that may cause minor or moderate injury if the recommended precautions are not followed.

Record your attachment serial number and purchase date in the section reserved below (there is no serial number on the subframe). Your dealer requires this information to give you prompt, efficient service when ordering replacement parts. Use only genuine parts when replacements are required.

If warranty repairs are required please present this registration booklet and original sales invoice to your selling dealer for warranty service.

This manual should be kept for future reference.

Please check if you have received all the parts for your kit with the list of the bag and the list of the box.

SERIAL NUMBER : _____
(IF APPLICABLE)

MODEL NUMBER: _____

PURCHASE DATE : _____



SAFETY PRECAUTIONS



Careful operation is your best insurance against an accident. Read this section carefully before operating the vehicle and accessory. This accessory is capable of amputating hands and feet and throwing objects. Failure to observe the following safety instructions could result in serious injury. All operators, no matter how experienced they may be, should read this and other manuals related to the vehicle and accessory before operating. It is the owner's legal obligation to instruct all operators in safe operation of the accessory.

GLOSSARY:

In this manual, right and left sides are determined by sitting on the seat of the vehicle facing forward.

In this manual, "accessories" means attachments (snowblower, rotary broom, blade etc.) that you install on the vehicle (lawn tractors, A.T.V. s etc).

TRAINING:



This symbol, "Safety Alert Symbol", is used throughout this manual and on the accessory's safety labels to warn of the possibility of serious injury. Please take special care in reading and understanding the safety precautions before operating the vehicle and accessory.

1. Read this owner's manual carefully. Be thoroughly familiar with the controls and proper use of the vehicle and accessory. Know how to stop the unit and disengage the controls quickly.
2. Never allow children to operate the vehicle nor the accessory. Never allow adults to operate the vehicle nor the accessory without proper instructions.
3. No one should operate the vehicle nor the accessory while intoxicated or while taking medication that impairs the senses or reactions.
4. Keep the area of operation clear of all people, particularly small children and pets.
5. Never start or operate the accessories except from the operator's station on the power unit except if this is impossible.

PREPARATION:

1. Thoroughly inspect the area where the accessory is to be used and remove door mats, all foreign objects and the like.
2. For motorized accessories, disengage all clutches and shift into neutral before starting engine.
3. Do not operate the accessory without wearing adequate winter outer garments. Avoid loose fitting clothing that can get caught in moving parts. Wear footwear that will improve footing on slippery surfaces.

4. Handle fuel with care, it is highly flammable.
 - a) Use approved fuel container.
 - b) Never add fuel to a running engine or hot engine.
 - c) Fill fuel tank outdoors with extreme care. Never fill fuel tank indoors.
 - d) Never fill containers inside a vehicle, or on a truck or a trailer bed with a plastic liner. Always place containers on the ground, away from your vehicle, before filling.
 - e) When practical, remove gas-powered equipment from the truck or trailer and refuel it on the ground. If this is not possible, then refuel such equipment on a trailer with a portable container, rather than from a gasoline dispenser nozzle.
 - f) Keep the nozzle in contact with the rim of the fuel tank or container opening at all times, until refueling is complete. Do not use a nozzle lock-open device.
 - g) Replace fuel cap securely and wipe up spilled fuel.
 - h) If fuel is spilled on clothing, change clothing immediately.
5. Never attempt to make any adjustments while the engine (motor) is running (except when specifically recommended by manufacturer).
6. Let the vehicle and accessory adjust to outdoor temperatures before using.
7. Never use an accessory without proper guards, plates, or other safety protective devices in place
8. Always make sure to wear the appropriate safety equipment required (glasses, muffs, mask...) for each type of product. See operation section.
9. Always make sure of having safe traction on the vehicle by using the recommended accessories (chains, A.T.V. tracks, counterweights...). See operation section.
10. Always make sure all components are correctly installed. (driveline securely attached and locked at both ends, belts properly installed...)
11. If applicable, always handle the winch cable with thick leather gloves.
12. **Never modify the accessory or any part without the written consent from the manufacturer.**



SAFETY PRECAUTIONS



OPERATION:

1. Do not put hands or feet near, under or inside rotating parts.
2. Exercise extreme caution when operating on or crossing gravel drives, walks or roads. Stay alert for hidden hazards or traffic. Do not carry passengers.
3. After striking a foreign object, stop the engine (motor), disconnect the wire from the spark plug(s) and keep wire away to prevent accidental starting. Thoroughly inspect the accessory for any damage and repair damage before restarting and using the accessory.
4. If the unit should start to vibrate abnormally, stop the engine (motor) and check immediately for the cause. Vibration is generally a warning of trouble.
5. Take all possible precautions when leaving the vehicle unattended. Disengage the power take-off, lower the attachment, place the transmission into neutral, set the parking brake, stop the engine and remove the ignition key.
6. Do not run the engine indoors, except when starting the engine and for transporting in or out of the building. Do not operate or let motor run in a storage area without ventilation because gas contains carbon monoxide which is odorless, colorless and can cause death.
7. Never use the accessories across the face of slopes, go from top to bottom. Exercise extreme caution when using equipment on slopes. Do not attempt to clear a steep slope.
8. Never tolerate bystanders in the working zone. Never use an accessory in the direction of bystanders, it might throw gravel or debris that can hurt people or damage property.
9. Never operate the accessory at high transport speeds on slippery surfaces. Use care when backing up.
10. Do not carry passengers.
11. Disengage power to the accessory when it is transported or not in use.
12. Never operate the accessory without good visibility or light.
13. Keep the accessory away from heat sources or flames.
14. If applicable, never handle the winch cable or hook while in tension.

MAINTENANCE AND STORAGE

1. When cleaning, repairing or inspecting the vehicle and accessory: stop the engine, set brake, remove ignition key, and wait that all moving parts have stopped. For gasoline engine, disconnect wire from the spark plug(s) and keep wire away to prevent accidental starting.
2. Check all the bolts and components at frequent intervals to make sure that they are properly tightened.
3. Never store a motorized accessory with fuel in the fuel tank inside a building where ignition sources are present such as hot water and space heaters, clothes dryers, and the like. Allow the engine to cool before storing in any enclosure.
4. Always refer to the owner's manual when you store the accessory and vehicle for a prolonged or an unspecified length of time.
5. Maintain or replace safety and instruction labels, as necessary.
6. For winter accessories, (if applicable), let the engine run for a few minutes after clearing snow in order to prevent the rotary parts from freezing.
7. Inspect the vehicle's and accessory's air filter (if applicable) every day. Clean it or replace it as necessary. Change the oil more often when working in dusty conditions. See the vehicle's and accessory's owner's manual.

TRANSPORT





1. Review Transport Safety instructions in vehicle manual before moving.
2. Check with local authorities regarding transport on public roads. Obey all applicable laws and regulations.
3. Make sure all lights and reflectors that are required by the local highway and transport authorities (example : SMV (Slow Moving Vehicle)) are in place, are clean, and can be seen clearly by all overtaking and oncoming traffic.
4. Never have the equipment in operation during transport.
5. Always travel at a safe speed.



SAFETY DECALS

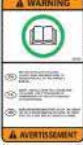

REPLACE IF DECALS ARE DAMAGED
SEE PARTS BREAKDOWN FOR DECAL LOCATION

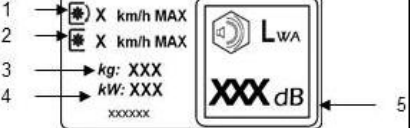
Symbol	Description
Decal #105126 	To avoid serious injury: Keep hands, feet & clothing away from rotating auger while engine is running.
Decal #105127 	To avoid serious injury: Keep hands out of this discharge chute while engine is running.
Decal #105128 	To avoid serious injury: Keep hands, feet & clothing away. Do not attempt to install or remove drive belt without reading owner's manual.
Decal #105130 	Before installing or using: Locate, read and make sure to understand all of the owner's manual.
Decal #105131 	Refer to owner's manual about wearing safety glasses, ear muffs and mask. Refer to owner's manual for use of counter weights, cat tracks and tire chains.
	1-Do not drive faster than 3 KM/H when the snowblower is in operation. 2-Do not drive faster than 10 KM/H when the snowblower is in the raised position. 3-The head of the snowblower weighs 96 kg. (without engine). 4-The engine wattage. (See specification of the engine installed). 5-The sound pressure level (See specification of the engine installed).

ASSEMBLY

CONVERSION TABLE	
1" (po, in)	25.4 mm
1' (pi, ft)	0.3 m
1 psi (lb/in ²)	6.89 kPa
1 lb	0.45 kg
1 lbf	4.4 N
1 m/h (mi/h)	1.61 km
1 hp (cv)	0.75 kW

GLOSSARY	
Quad = V.T.T., A.T.V.	
Véhicule tout terrain	V.T.T.
All terrain vehicle	A.T.V.
Utility Vehicle	U.V
Véhicule Utilitaire	V.U.
P.T.O. = P.D.F	
Power take-off	(P.T.O)
Prise de force	(P.D.F)

ASSEMBLY INSTRUCTIONS

IMPORTANT: UNLESS OTHERWISE SPECIFIED TORQUE ALL BOLTS ACCORDING TO TORQUE SPECIFICATION TABLE (SEE TABLE OF CONTENTS) WHEN STATED: TIGHTEN FIRMLY. REFER TO PARTS BREAKDOWN SECTION FOR PART IDENTIFICATION.

IMPORTANT: THE VEHICLE MUST BE EQUIPPED WITH A 1 7/8" TOW HITCH BALL IN ORDER TO INSTALL THE VANTAGE SNOWBLOWER.

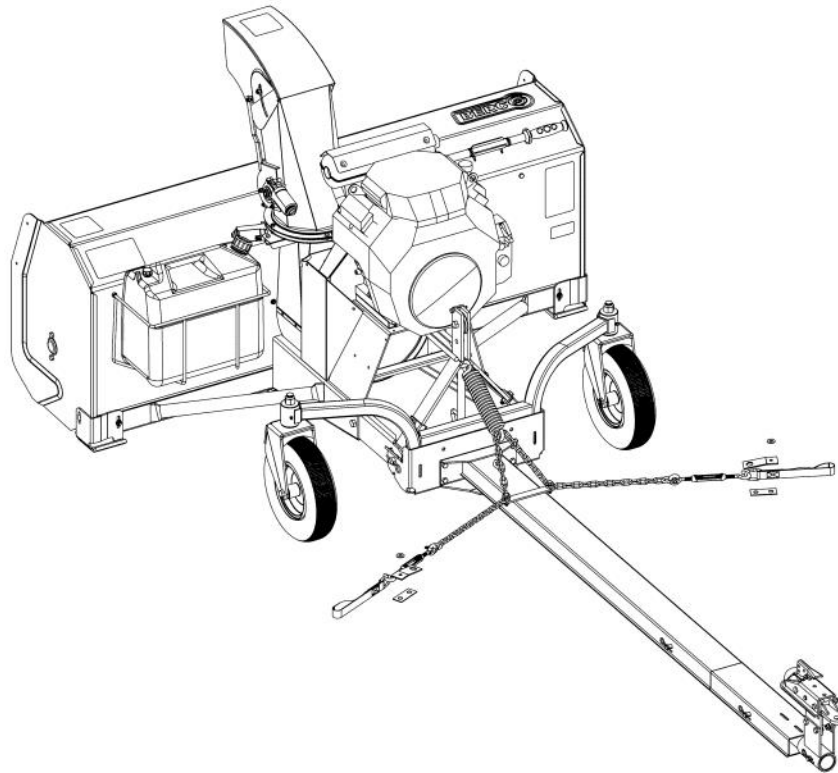

Figure 1 - Overall view of the Vantage snowblower

TOOLS REQUIRED

- 1 Ratchet
- 3 Wrenches 7/16", 1/2", 9/16"
- 3 Sockets 7/16", 1/2", 9/16"
- 1 Hexagonal wrench 5/32"
- 1 Wrench (for the nuts on the vehicle's battery post)

ASSEMBLY

SNOWBLOWER PREPARATION:

Refer to parts breakdown section for parts identification.

Install the nylon rotation ring (item 1) over the opening (item 2) as shown and align the notches.

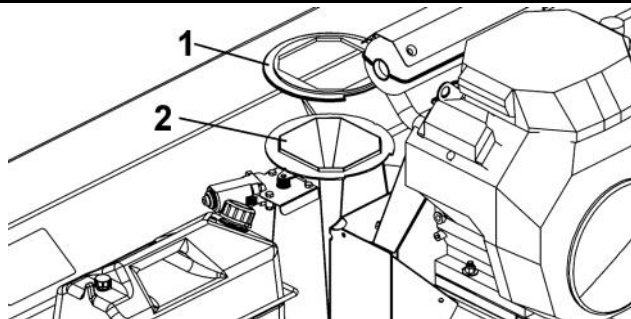

Install the nylon rotation ring

Install the rotation ring (item 1) over the opening as shown.

NOTE: Place grooves of the rotation ring onto the grooves of the rotation motor and place notch (A and B) as shown.

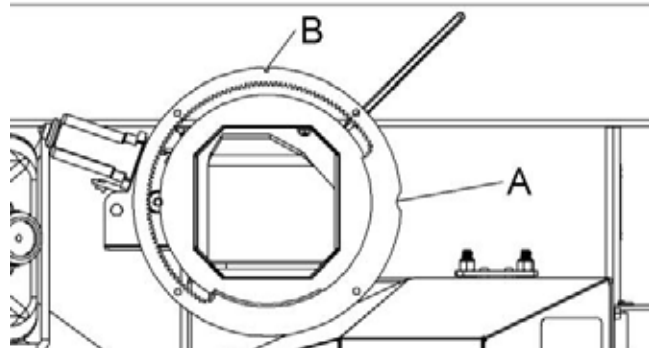
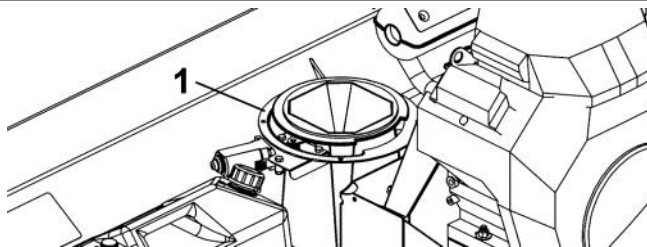

Install the rotation ring

Install the chute (item 1) over the nylon rotation ring (item 2). Turn the chute to make sure it turns freely. Place the chute at a 45° angle as shown. Insert the hex bolts 1/4" x 1" (item 3) under the rotation ring (item 6) in each hole as shown. Insert the spacers (item 4) on the hex bolts between the rotation ring and the chute. Secure in place with the 1/4" nylon insert lock nuts (item 5).

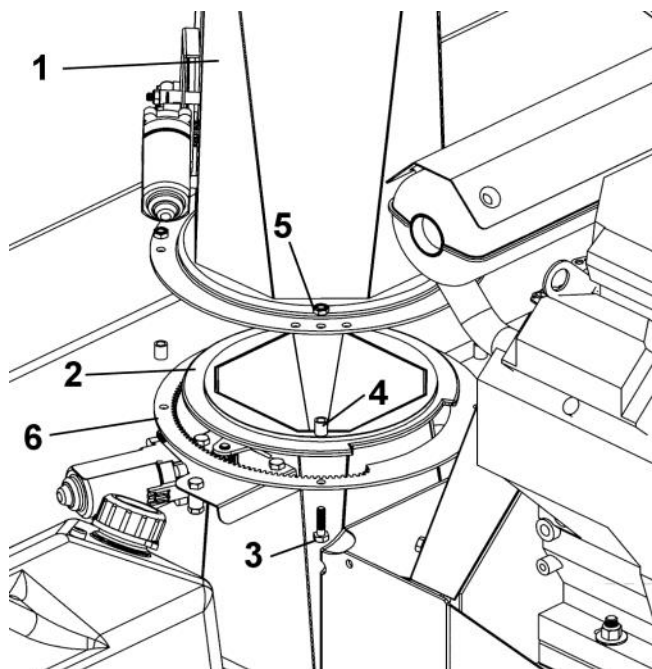

Install the chute

ASSEMBLY

Insert the 1/4" x 1/2" hex bolts (item 1) in the holes as shown.
Install the retaining plate (item 2) under the chute as shown.
Secure in place with the 1/4" nylon insert lock nuts as shown.

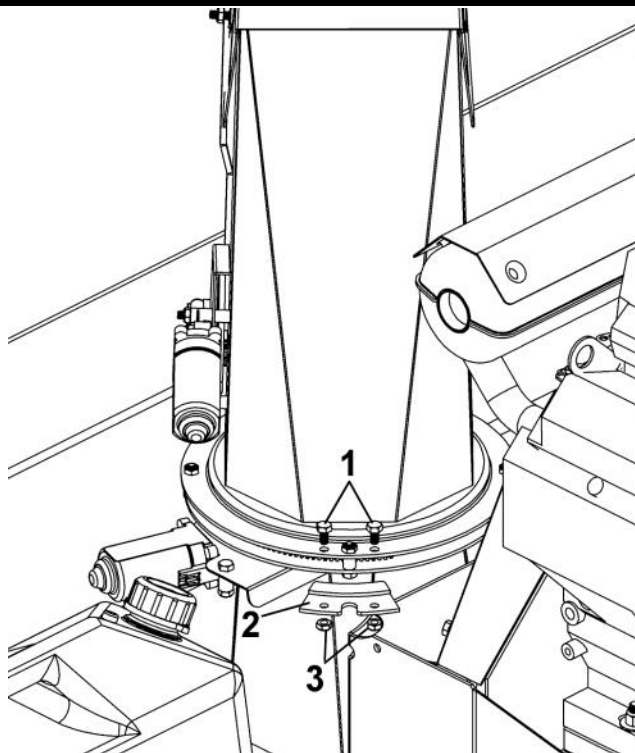

Install the retaining plate

VEHICLE PREPARATION:

Choose one of the three following options as a means of fastening the subframe.

OPTION A:

Install the lift strap (**item 1**) by making a loop around the front suspension arm of the vehicle.
Tighten the loop firmly.

OPTION B:

Remove the nut and bolt from the vehicle's front suspension arm. Secure the bracket (**item 3**) with a bolt, flat washer and nut (**item 2**).
Do not tighten the nut too firmly.

OPTION C:

Remove the nut and bolt from the vehicle's front suspension arm. Secure the bracket (**item 4**) with a bolt, flat washer and nut (**item 2**).
Do not tighten the nut too firmly.

NOTE: Repeat the operation on the other side of vehicle.

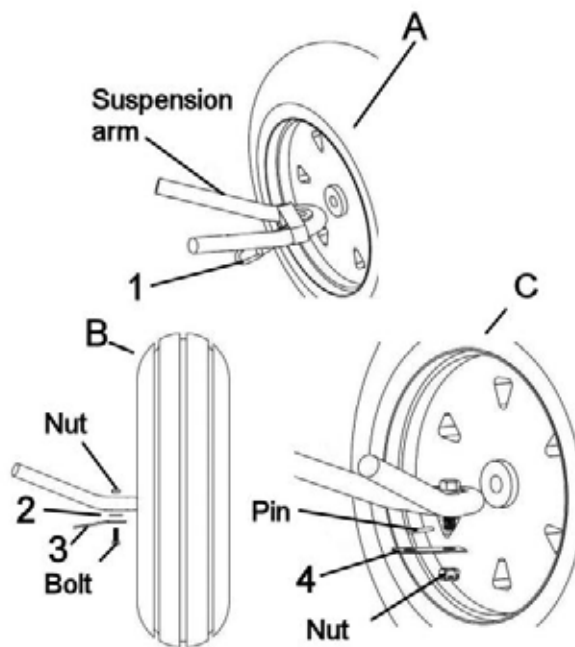

Install the lift strap or the brackets.

ASSEMBLY

PREPARING THE SUBFRAME

Assemble the wheel support (item 1) on the subframe (item 2) with four hex bolts $3/8"$ x $1"$ (item 3) and four flange nuts $3/8"$ (item 4).

NOTE: The set of holes used to assemble the wheel support to the subframe depends on the height of the vehicle. Once installed the subframe must be parallel with the ground.

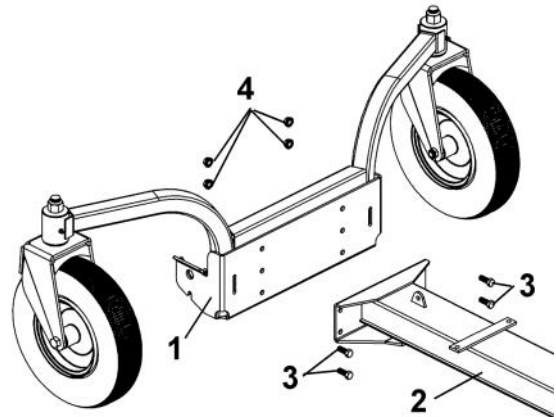

Install the wheel support to the subframe

Install the assembled turnbuckles (item 1) and chain (item 2) on the bracket (item 6) that is welded on the subframe (as shown).

Secure the chains with two hex bolts $5/16"$ x $1"$ (item 3), two flat washers $3/8"$ (item 4) and two nylon insert lock nuts $5/16"$ (item 5).

Slightly tighten the nuts to allow the parts to move freely.

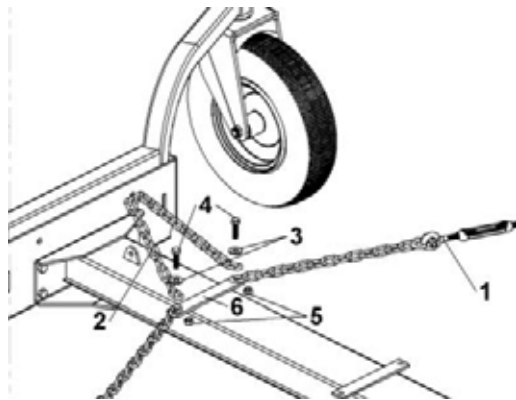

Install the assembled turnbuckles

Install the snowblower (item 1) to the wheel support (item 2). Slide the pin (item 3) through the assembly to hold everything together. Hold the pin in place with the hair pin 4mm (item 4) as shown.

NOTE: Make sure the pin is in the locked position.

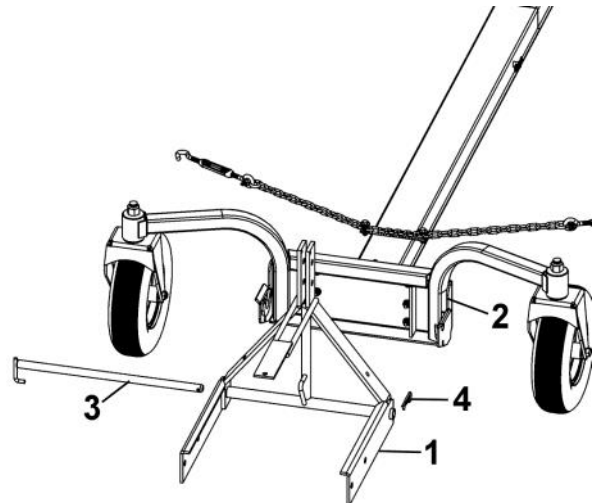

Install snowblower

ASSEMBLY

Among the three following configurations, choose the height of the hitch support. There must be a maximum of ground clearance.

(Configuration A) does not have the hitch support plates (item 1).

If applicable, assemble the hitch support plates on the hitch support (item 2) with four hex bolts $\frac{3}{8}$ " x $\frac{3}{4}$ " (item 3) and four nylon insert lock nuts $\frac{3}{8}$ ".

Secure the hitch (item 4) on the two hitch support plates or on the hitch support with a hex bolt $\frac{3}{8}$ " x 3" (item 5) and one nylon insert lock nut $\frac{3}{8}$ ".

Tighten firmly

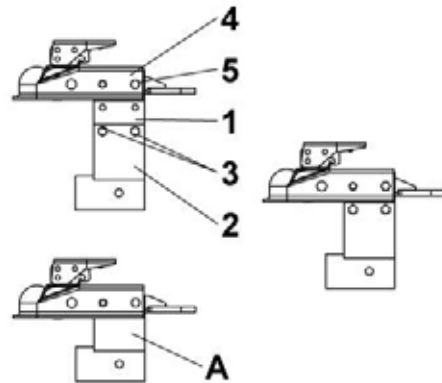

Adjusting the hitch support

There are seven different positions on the adjustment tube (item 1) (the adjustment tube can be inverted) to adjust the length of the subframe.

To choose the right adjustment, insert the adjustment tube into the subframe (item 2) and insert the rear bracket (item 3) on the adjustment tube. Slide the hitch support (item 4) on the rear bracket. Do not secure.

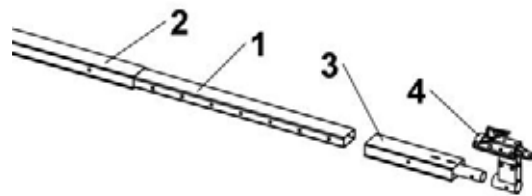

Assembling the subframe

Drive the vehicle over the subframe, make sure the caster wheels do not touch the front wheels of the vehicle.

Identify the right length of the subframe (item 1) and secure in place with two long pins (item 2), a short pin (item 3) and three hair pins 3mm (item 4).

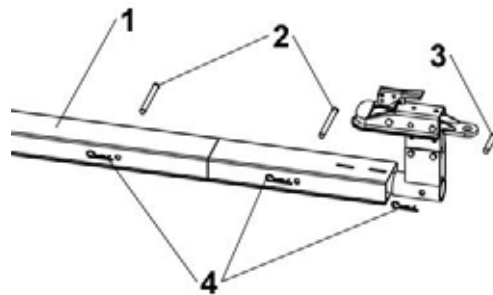

Securing the subframe

ASSEMBLY

INSTALLING ON THE VEHICLE

Place the hitch (item 1) on the tow hitch ball and secure in place with a pin (item 2) and a hair pin (item 3).

IMPORTANT: Make sure the vehicle never comes into contact with the subframe even when the vehicle's suspensions are compressed to the maximum.

NOTE: It is possible to turn the hitch support to facilitate driving the vehicle over the subframe.

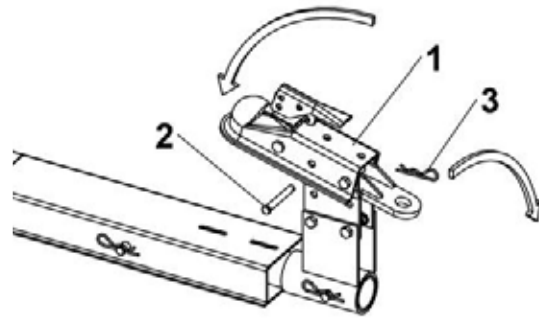

Installing the subframe on the tow hitch ball

Operation instructions for hitch coupler:



WARNING



TO PREVENT INJURIES:

Always check that ball is completely inserted into hitch coupler socket and that under jaw is securely closed around the bottom of ball.

Always check that hitch coupler handle is properly locked before its use.

Always examine hitch coupler and ball for damage before using, replace if damaged.

NOTE: Correct adjustment will allow the handle to be released with moderate pressure applied to the handle.

To open, pull up on hitch coupler handle and rotate forward.

Place hitch coupler on ball.

When ball is completely nested in ball socket, rotate hitch coupler handle backward until handle is in locked position.

Always check tightness before using the tow hitch.

Be sure hitch coupler handle is in locked position.

Lock the handle (item 1) into position over the ball in the hitch coupler. Tighten the lock nut (item 2) against the spring so that the hitch coupler is not loose on the ball.

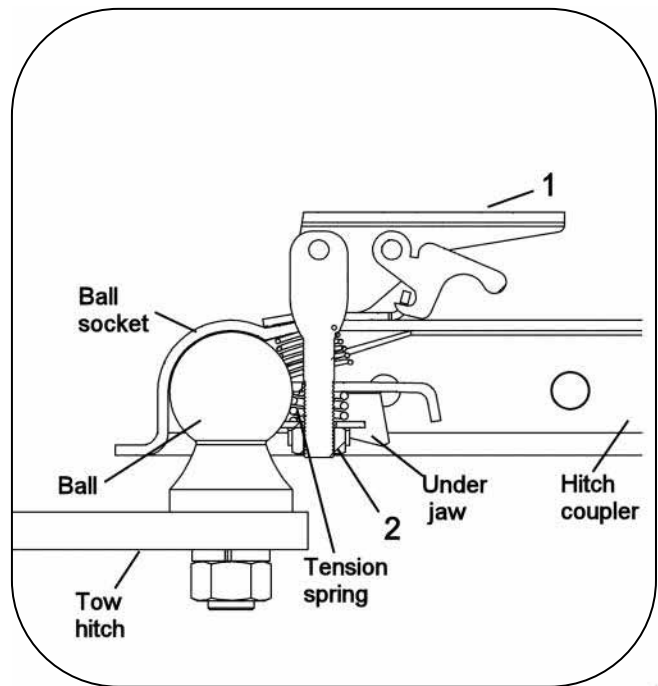

Adjusting the hitch coupler

ASSEMBLY

Hook the turnbuckles (item 1) in the brackets or the lift straps. Tighten the turnbuckles firmly.

IMPORTANT: After adjusting the turnbuckles, tighten firmly the nuts that secure the brackets on the vehicle's suspension arms. Make sure to lock the nuts with the original locks. Furthermore, tighten firmly the turnbuckle assembly nuts that secure them to the subframe.

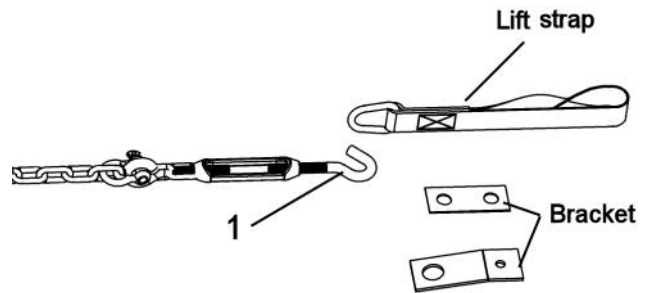

Install the turnbuckles

NOTE: In the event where the vehicle is equipped with a prominent front bumper or tracks, the assembled turnbuckles (**item 3**) will become too angled. Relocate the assembled turnbuckles from plate 1 towards plate 2.

IMPORTANT: To avoid any damages to the subframe or vehicle, plate #2 must be placed in front of the wheels' center if the assembled turnbuckles are relocated.

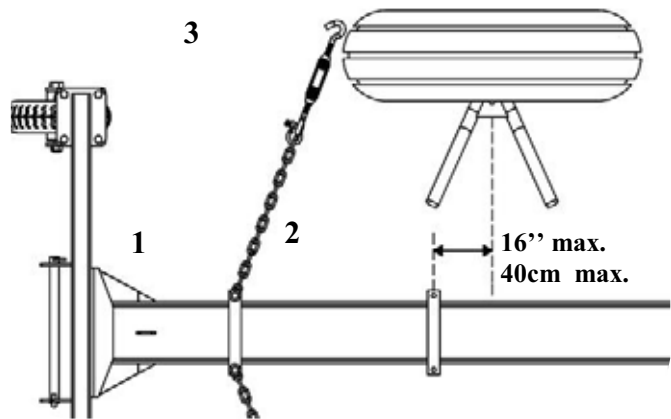

Verification of turnbuckles installation

For vehicles with a winch that is higher than 20" (510mm) from the ground, follow these instructions:

Install pulley (item 1) in the top hole of the lever with a 1/2" x 1 3/4" hex bolt (item 2) and secure in place with the nylon insert lock nut. Tighten firmly. Insert the winch hook (item 3) in the rod (item 4). Secure the winch cable by inserting the lynch pin (item 5) in the small hole (item 6).

For vehicles with a winch that is lower than 20" (510mm) from the ground, follow these instructions:

Install pulley (item 1) in the bottom hole (item 7) of the lever with a 1/2" x 1 3/4" hex bolt (item 2) and secure in place with the nylon insert lock nut. Tighten firmly. Insert the winch hook (item 3) in the rod (item 4). Secure the winch cable by inserting the lynch pin (item 5) in the small hole (item 6).

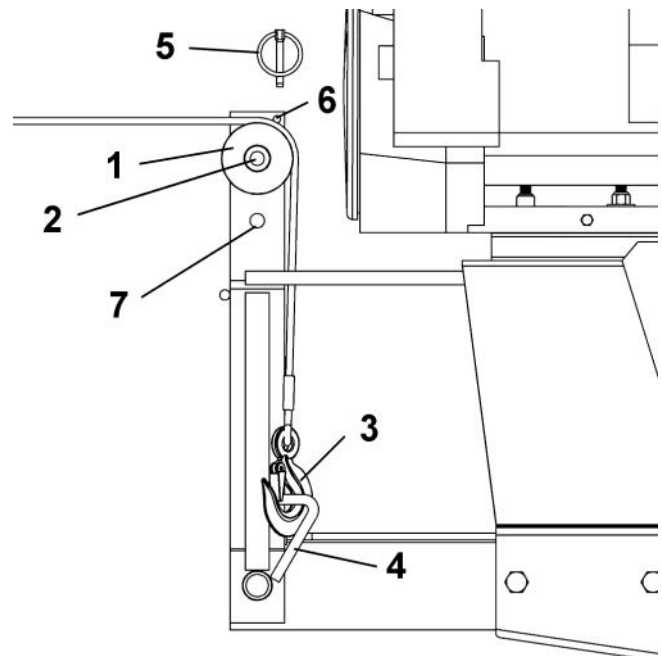

Install the winch hook

TIP: Thread the winch hook in front of the hitch as shown and then thread the cable over the pulley.

ASSEMBLY

CONTROL BOX INSTALLATION:

Disconnect the wires that are connected to the control box (item 3).
Install the box support (item 1) in an appropriate place . Drill holes if necessary. Secure the box support with the two 1/4" x 1/2" hex bolts and flange nuts.
Tighten firmly.
Install the control box on the box support.
Thread the wires that unites the accessory under the hood to the front of the vehicle.

NOTE: Excess of wire is available, if needed, under the engine.

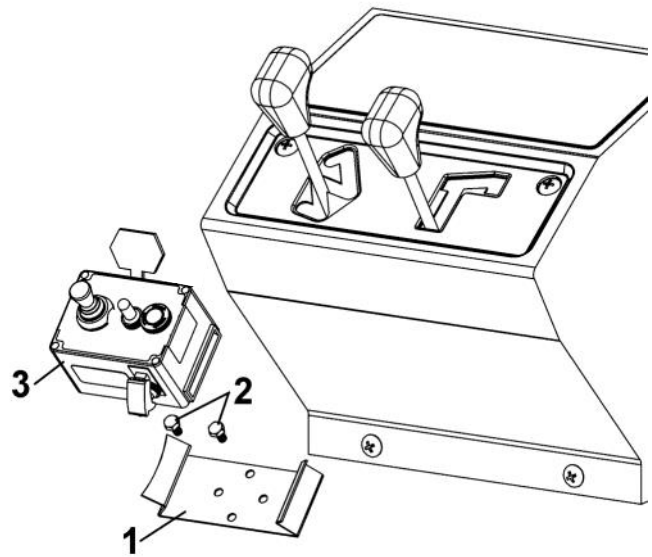

Install the control box

Connect wire assembly (104017) to the positive post on the vehicle's battery. Connect the black wire on the vehicle's frame.

IMPORTANT: The control box is equipped with a red emergency kill switch in case you need to stop the engine quickly.

NOTE: The emergency kill switch must be pulled out to start the engine's accessory.

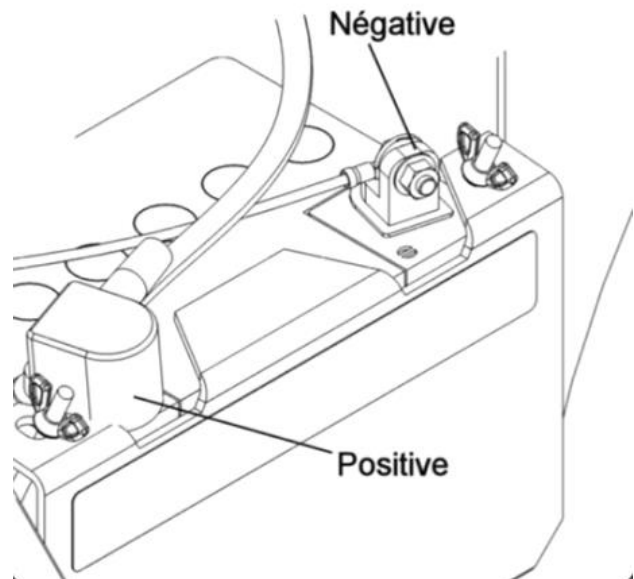

Connect the wire on the battery

Connect wiring of snowblower.

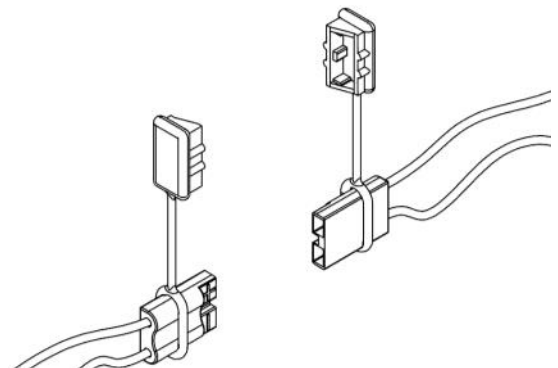

Wire assembly

ASSEMBLY

Connect the wire connector on the motor of the chute deflector (item 1)

Make sure the connectors are well connected together and tie the wire that is connected to the motor of the deflector with a nylon tie wrap (item 2) as shown. Cut off any excess of the tie wrap.

WARNING:

Be sure to leave enough wire length to be able to turn the chute freely and that no wiring comes into contact with the motor's muffler.

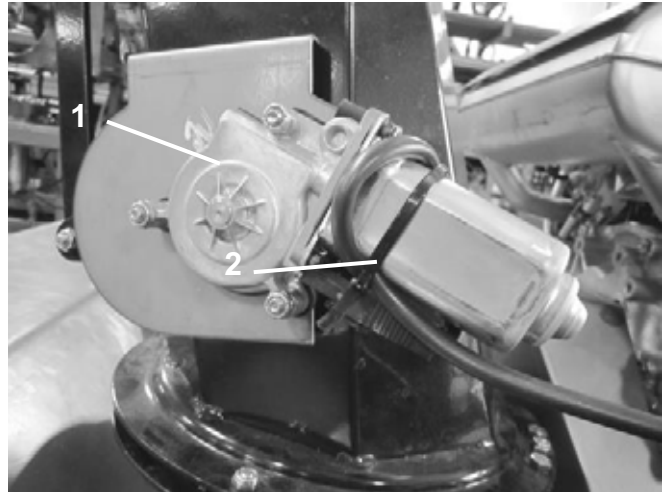

Secure the wires as shown

IMPORTANT: Take time to familiarize yourself with the location of the switches and with their functions.

DANGER: Always make sure that all the guards are installed before starting the snowblower engine.

DANGER: It is the responsibility of the person who installs the accessory to make sure the engaging system works well and that the snowblower disengages effectively at all times. It is imperative to make the necessary adjustments if applicable.

Identification of the switches:

1. Emergency kill switch. (**Pull out to start**).
2. Joystick to move the chute and the deflector.
3. Switch to activate the electric clutch.
4. Switch for optional light kit.

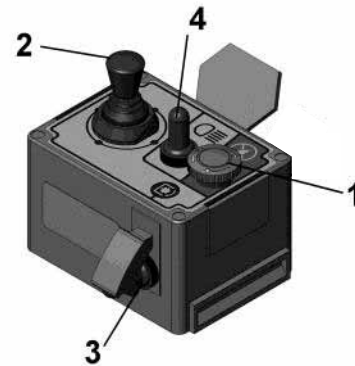

Identify the controls.

DANGER: For the next manipulations, make sure to clear the area in front of the snowblower and the outflow of the chute of all people or objects.

1. Manipulate the four position switch (item 2) and make sure the chute deflector and rotation works well.
2. Activate the electromagnetic clutch switch (item 3). Make sure the clutch engages and disengages.
3. Engage the electromagnetic clutch. Try to start the snowblower engine. Make sure the engine does not start.

4. Disengage the electromagnetic clutch. Try to start the snowblower engine. Make sure the engine starts.
5. While the engine is running, activate the kill switch (item 1). Make sure the engine stops. Deactivate the kill switch by turning it clockwise.
6. If the snowblower is equipped with a light, activate the light switch (item 4) make sure it activates the light.

ASSEMBLY

INSTALLING THE SPRING AND ADJUSTING THE LIFTING HEIGHT OF THE SNOWBLOWER.

IMPORTANT:

It is very important that the snowblower engine does not come into contact with the vehicle.

If necessary, use on each side one or two shims (item 2) supplied with the kit to limit the lifting height. Secure in place with a hex bolt $3/8'' \times 1\ 1/2''$ (item 3), a flat washer $7/16''$ (item 4) and a nylon insert lock nut (item 5) as shown.

Lift the snowblower to its maximum height, insert the spring (item 1) in the chain (item 6) and on the welded rod (item 7) as shown.

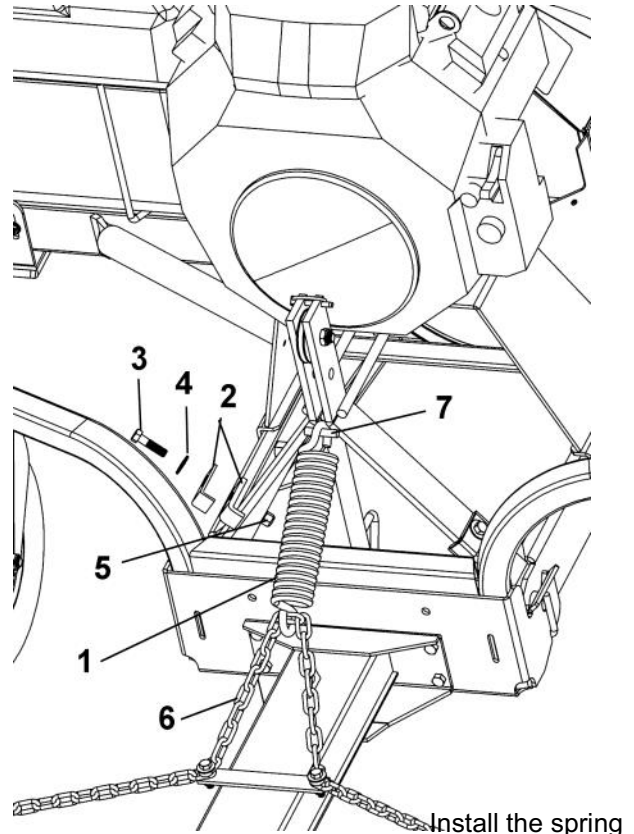

VERIFYING THE ASSEMBLY

THE LENGTH OF THE SUBFRAME

When the vehicle is advancing in a straight line, make sure the wheels of the subframe do not come into contact with the wheels of the vehicle.

When the snowblower is raised to its maximum, make sure the snowblower engine does not come into contact with the vehicle.

PRESSURE OF THE TIRES ON THE SUBFRAME

Verify and adjust the pressure of the tires of the subframe at 50 psi.

The tire pressure must be even on both sides.

OPERATION



WARNING



Read the vehicle's owner's manual carefully. Be thoroughly familiar with the controls & proper use of the attachment. Know how to stop the unit & disengage the controls quickly.



WARNING



TO PREVENT INJURIES:

Start the engine, engage and disengage the clutch to be sure it functions normally. Make sure the emergency switch is working perfectly. Make sure all the controls are working well.

SNOWBLOWER OPERATION

1. Make sure the snowblower is clear of snow;
2. Make sure the auger and impeller operate freely.
3. Make sure the electromagnetic clutch is deactivated and the kill switch is disengaged.
4. Start the snowblower engine
5. Before activating the electromagnetic clutch, the snowblower engine must run at maximum R.P.M.
6. Operate the snowblower safely.

IMPORTANT: Use full engine r.p.m. when removing wet, sticky snow. low r.p.m. power will tend to plug the chute.

ELECTRICAL CONTROLS

See the "Installation of the control box" section for the identification of the electrical controls of the snowblower.

LIFTING AND LOWERING THE SNOWBLOWER

Use the winch control switch to raise and lower the snowblower.

IMPORTANT: To extend the lifespan of the subframe, immediately release the switch when the accessory hits the stopper in the raised position.

ENGINE OPERATION

Operate the engine according to the instructions in the engine's owner's manual.



WARNING



Never touch with your hands or feet the snowblower's fan, auger or the chute because this is the most frequent cause of accidents associated with snowblowers.



DANGER



Never let the snowblower motor run without all guards in place.



WARNING



To prevent accidents :

- Always use the snowblower in well lighted areas.
- It is essential to install and use a light on the front of the snowblower for night use or in shadowy conditions.



WARNING



To prevent injuries and for more traction when using the snowblower:

- Do not drive faster than 3 km/hr (2 m/hr) with snowblower on the ground.
- Do not drive faster than 10 km/hr (6 m/hr) with the snowblower in raised position.
- Always disengage the electromagnetic clutch when the snowblower is in the raised position.
- Do not operate on a slope greater than 10%.
- Vehicle manufacturer approved tire chains are required.
- Maximum drawbar pull provided for at the hitch ball coupling: 3560N (800 lbs)
- Maximum vertical load provided for on the hitch ball coupling: 360N (80 lbs).
- Ear muffs and safety glasses are recommended.

BURNISHING PROCEDURE

The burnishing procedure must be performed before the first utilisation of the snowblower and after a prolonged period of inactivity. Burnishing the engaging system will ensure proper performance and will help avoid damages.

1. Make sure the fan and the augers are free of any obstruction. Start the motor.
2. Engage electric clutch.
3. Disengage electric clutch and wait for all moving parts to stop.
4. Repeat procedure (steps 2 & 3) 10 times.

OPERATION



SNOWBLOWING TECHNIQUE

When removing snow, do not use the snowblower as a dozer blade to push snow. Allow snowblower to ingest snow at its own speed. If the speed of your A.T.V. is too fast, the snowblower may become overloaded and plugged.

SKID SHOE ADJUSTMENT

Level paved surface: Adjust skid shoes to allow 3/16" to 1/4" or 5 mm to 7 mm clearance (A) between cutting edge and surface.

Uneven or gravel surface: Adjust skid shoes to allow 1/2" to 5/8" or 13 mm to 16 mm clearance (A) between cutting edge and surface.

	DANGER	
<u>DANGER ZONE</u>		
<p>It is the snowblower operator's obligation to make sure there are no people or objects that can be thrown in this zone when the snowblower is running.</p>		

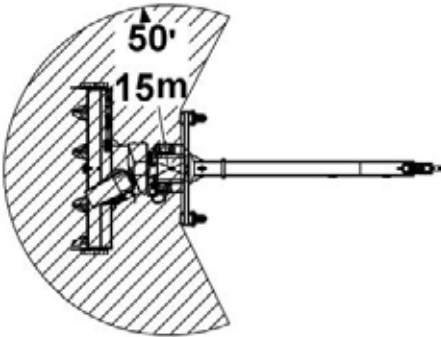

Danger zone

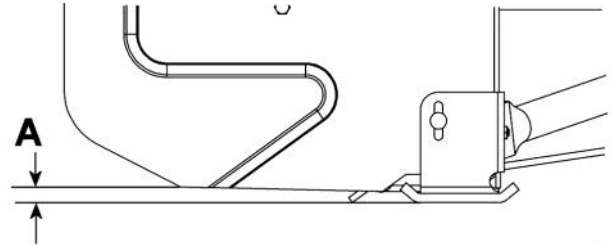

Skid shoe adjustment

MAINTENANCE



WARNING



Before doing any snowblower maintenance, assembling or dismounting:
Apply parking brakes of the vehicle.
Stop the snowblower engine and remove the ignition key
Disconnect the wire from the spark plug(s) and keep away from spark plug(s) to prevent accidental starting.



WARNING



If the snowblower is in the raised position, always make sure to provide adequate blocking before working under the snowblower.



WARNING



- Do not attempt to clear plugged chute, auger or fan of snow while the snowblower's engine is running.
- Disengage snowblower.
- Lower snowblower onto ground.
- Set the parking brake.
- Stop engine, remove the ignition key, disconnect the wire from spark plug(s) and keep away from spark plug(s) to prevent accidental starting.
- Make sure all moving parts have stopped.
- Do not use hand to unplug chute, use the chute shovel supplied with the snowblower.

ENGINE MAINTENANCE

Maintain the engine according to the instruction in the engine's owner's manual.

SNOWBLOWER MAINTENANCE

Check mounting bolts at frequent intervals for proper tightness in order to prevent costly repairs. Make sure your snowblower is in safe working condition.

PRESSURE OF THE TIRES ON THE SUBFRAME

Verify and adjust the pressure of the tires of the subframe at 50 psi.

The tire pressure must be even on both sides.

CLEANING A CLOGGED DISCHARGE CHUTE

Whether it is the snowblower auger, the fan or the chute that clogged, it is essential to follow these instructions to the letter.

1. Disengage the electromagnetic clutch
2. Lower the snowblower to the ground and apply the vehicle's hand brake;
3. Stop the snowblower engine, remove the key and wait for all the rotating parts to stop turning.
4. Disconnect the wire from the spark plug(s) and keep away from spark plug(s) to prevent accidental starting;

WARNING: Always use the chute shovel supplied with the snowblower in order to unclog the snowblower, **never use your feet or hands.**

SNOWBLOWER PULLEY REPLACEMENT OR ALIGNMENT

Clean the parts before aligning or replacing the pulleys. Apply some "Loctite" 2760 on the key and the set screws. Tighten firmly.

CUTTING EDGE MAINTENANCE

Verify from time to time the wearing on the cutting edge to make sure you do not wear out the base of the snowblower's chassis. This cutting edge is reversible. Unscrew the bolts and turn the cutting edge,

Reinstall with new carriage bolts 5/16" x 3/4" grade 5 and new lock nuts 5/16".

MAINTENANCE

LUBRICATION

SUBFRAME WHEELS: Grease the wheel axles, the fork pivots after every sixteen hours of use. Apply oil at all pivot points.

CHUTE ROTATION SYSTEM: Oil the base of the chute every sixteen hours of operation.

GEAR BOX :

Change oil after the 1st 100 hours of use. Afterwards, every 2500 hours or 6 months.

Oil type used: SAE 980W900

The gear box should have a total of 500ml of oil or filled just above the output shaft (see figure)

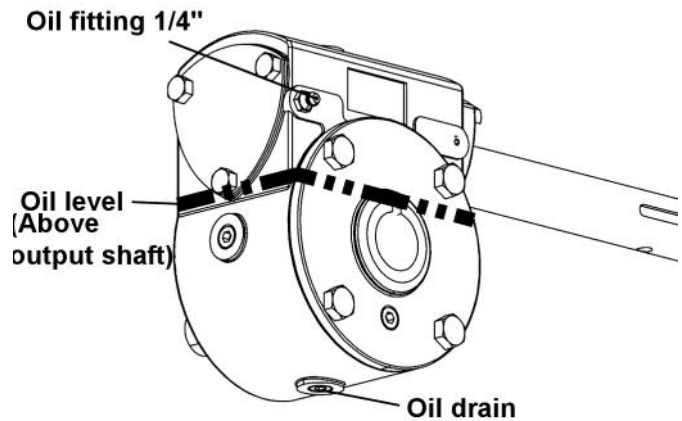

Oil level in the gear box

AUGER AND FAN SHEAR BOLT REPLACEMENT

IMPORTANT: The shear bolts are to be considered a preventive measure and not an assured protection. Operator vigilance is required. Thoroughly inspect the areas where the snowblower is to be used and remove all foreign objects.

TO AVOID DAMAGE TO THE SNOWBLOWER:

Use only the original shear bolts

(#105627 for the fan et #106443 for the auger).

The use of any other shear bolt will not insure any protection and may void the warranty.

IMPORTANT: When replacing the auger shear bolts it is very important to replace the augers in the same position as shown in figure to avoid damage to the snowblower and to ensure maximum efficiency.

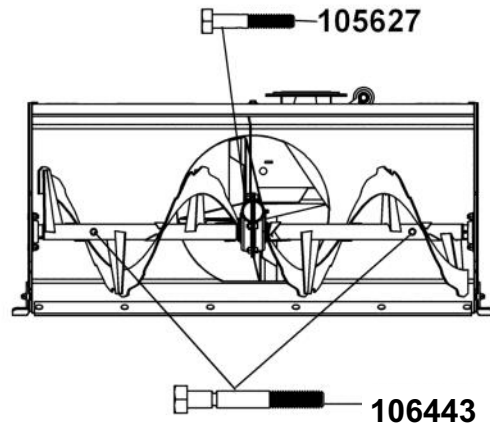

Shear bolt

Belt replacement

MAINTENANCE



CAUTION



Never use the snowblower without the belt guard.

BELT REPLACEMENT:

For belt part number, refer to parts breakdown section for parts identification.

- a) Remove the belt guard (item 1) by removing the three hex bolts $1/4"$ x $1/2"$ (item 2) and the three lock washers.
- b) Remove the hair pin (item 3) and the pin (item 4). Raise the lever (item 5) to remove the tension on the belts.
- c) Remove the old belts (item 6) and install the new ones. Make sure the belts are matched up and sold as a pair.
- d) Reapply tension on the belts and secure the lever in place with the pin and hair pin.
- e) Reinstall the belt guard.

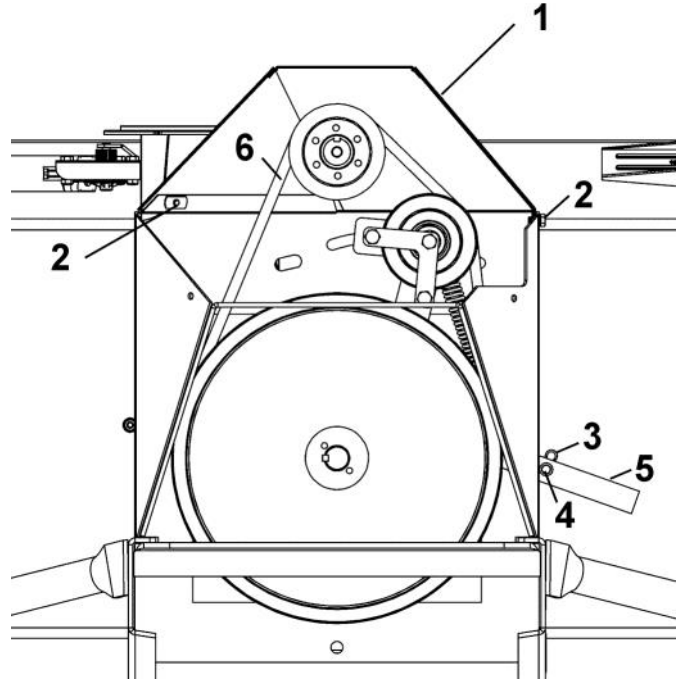

Belt replacement

MAINTENANCE

REPLACING ONE OR TWO SECTIONS OF THE AUGERS AND / OR THE GEAR BOX

For belt part numbers, refer to snowblower parts breakdown section for parts identification

Snowblower must be detached & disconnected from the vehicle to replace the auger or the gear box.

- a) Remove the gas tank from the support (place on the ground to avoid any spills)
- b) Remove the belt guard.
- c) Remove the belts.
- d) Turn the snowblower face down (optional).
- e) Loosen the two set screws (item 1) on the pulleys (it may be necessary to heat the set screws and center of pulleys to soften the "loctite").
- f) Remove the pulleys.
- g) Loosen the two set screws (item 2) on the bearing behind the snowblower (it may be necessary to heat the set screws to soften the "loctite").
- h) Remove all the bolts (item 3) and the nuts that support the gear box and its support.
- i) Remove the assembly (gear box, its support, the fan and augers) from the snowblower and save the nylon bushings and bearings.
- j) Replace the appropriate parts. Insert the shaft and the key into the new gear box (if required).
- k) Install the new auger or augers on their respective side in the position shown with the same nylon bushings on the shaft of the new gear box as shown.
- l) Re-install parts by repeating steps backwards.

IMPORTANT: Clean the parts and apply some Loctite 2760 on the key of the pulleys and on the set screws of the bearings and those of the pulleys. Firmly tighten the set screws.

Follow the instructions in the belt replacement .

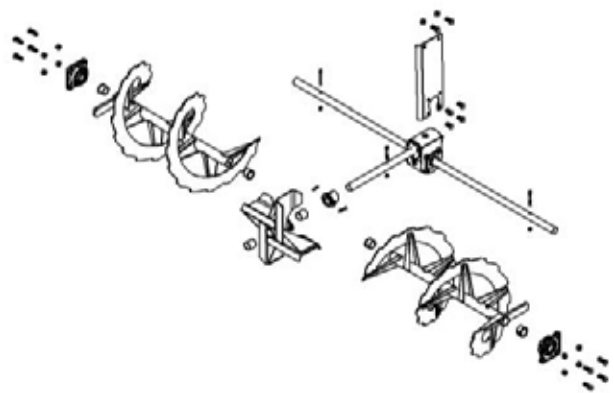
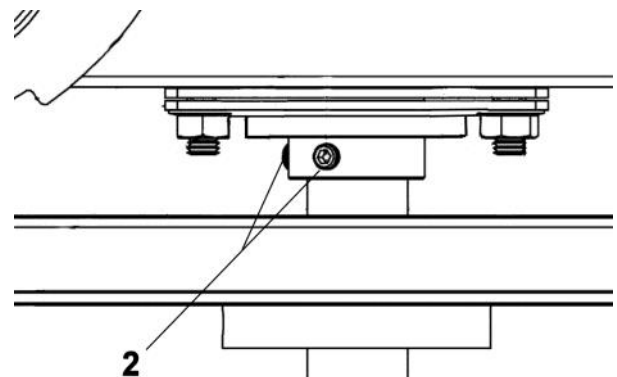
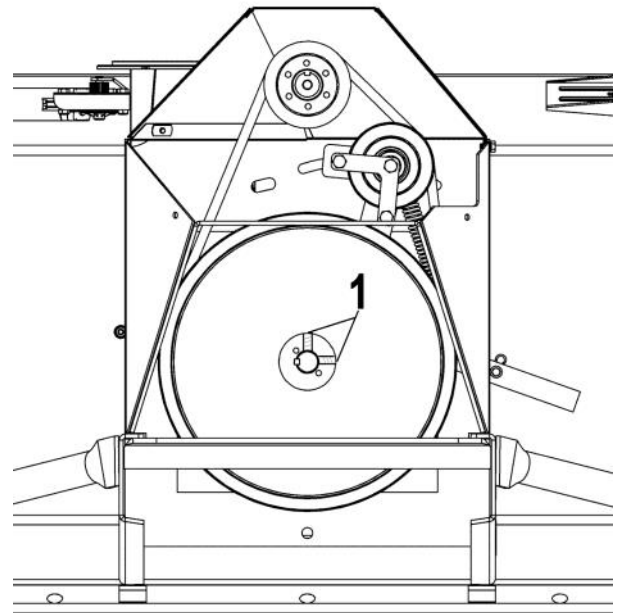

DISMOUNTING & STORAGE

DISMOUNTING

- a) Select a level surface, set parking brake, stop the engine, and remove the ignition key to prevent accidental starting.
- b) Lower the accessory to the ground.
- c) Disconnect the wires that unite the accessory to the vehicle.
- d) Unhook the turnbuckles from the front of the vehicle, (Tip: slacken one of the turnbuckles in order to keep the adjustment), the hook from the winch.
- e) Remove the assembled hitch support from the vehicle's tow hitch ball.
- f) Remove the vehicle.

STORAGE

- a) Clean snowblower and subframe thoroughly and repaint all parts from which paint has worn.
- b) List the replacement parts that will be needed to be replaced before the next season.
- c) Follow the instructions in the Lubrication section.
- d) Concerning the snowblower engine, follow the instructions in the engine owner's manual.
- e) Store the snowblower and the subframe in a dry place.

TROUBLESHOOTING

* Please refer to parts breakdown section for parts identification.

PROBLEM	POSSIBLE CAUSES	CORRECTIVE ACTION
Snowblower vibrates or is abnormally noisy . Snowblower bouncing up & down when ingesting snow.	Damaged pulley	Replace pulley
	Damaged bearing	Replace the bearing
	Fan or the augers are damaged	Remove and straighten or replace the parts
	Fan or auger bushings are worn	Replace with new bushings
	Augers are not positioned properly	Make sure the ends of the 2 augers are positioned 180 degrees from one and other when replacing shear bolts. (See auger & fan shear bolt replacement section in owner's manual)
Fan stops turning	Shear bolt is probably broken	Replace shear bolt (see maintenance section).
Auger stops turning	Shear bolt is probably broken	Replace shear bolt (see maintenance section).
Snowblower stops turning.	Belt is probably damaged or broken	Check and replace damaged belt
Belts is snapping, shredding, burning or worn in a specific place	Snowblower was engaged when plugged	Make sure the auger and the fan are not frozen or plugged before engaging
	Lack of tension on the belt	Adjust the tensioner spring or replace spring if stretched.
Belts show premature wear	Not the original belts	Always use the original belts
	Worn belt, Belt may be worn causing a slack.	Inspect the belt. Replace if required.
	Not the original shear bolts	Always replace the shear bolts with an original bolt.
	Imperfections in the pulleys	Verify if the pulleys are damaged. Verify that the pulleys are smooth without rust spots. Sand down the pulleys or replace them.
	Interference	Make sure that the belt does not come into contact with any other part, bolts, guides etc... when engaged.
Chute rotation is difficult	Dirt or ice may be underneath chute.	Dismount chute. Clean the base of chute and the rotation ring. Lubricate & re-install.
Chute plugs easily.	Snowblower engine running too slowly.	Run engine at full R.P.M. during snow blowing operation.
	Advancing too quickly with vehicle.	Reduce vehicle's speed.. Allow snowblower to ingest snow at its own speed.

TROUBLESHOOTING

PROBLEM	POSSIBLE CAUSES	CORRECTIVE ACTION
Snowblower digs into ground.	Ground is not frozen or too soft.	Adjust skid shoes lower so they may better support the snowblower. If problem persists, change skid shoes for heavy duty skid shoes (option #700243) which cover more surface and prevents snowblower from digging.
Snowblower does not raise evenly.	Pressure of the subframe tires is uneven from one side to another.	Tire pressure must be even on both sides. 50 p.s.i.
The engine does not start	The emergency button is pushed down.	The emergency button must be pulled up to start the engine of the snowblower.
	The electromagnetic clutch is activated.	Deactivate the electromagnetic clutch.
	Other reasons.	See owner's manual
Electric chute motor does not work.	Overheating of the motor.	These motors are equipped with an internal protector. Wait 10 minutes before using.
	Frozen motor or chute.	Slap the chute or wiggle from side to side.
	Defective control box or broken wire harness.	Replace control box or wire harness.
	Loose connectors or oxidation on connectors or motor.	Retighten or clean connectors. Or replace connector part # 106201.
Electric clutch slips	Insufficient electrical current.	Recharge vehicle's battery.
	Electrical current is cut off.	Replace damaged wiring.
	Clutch basket is contaminated.	Clean plates with brake cleaner.
Electric clutch is noisy or vibrates abnormally.	Mounting bolts are loose.	Tighten or replace bolts.
	Certain clutch components may be damaged.	Repair or replace damaged components.

In the case of where the wires become disconnected from the relay, refer to the drawing below to reconnect them in their proper place.

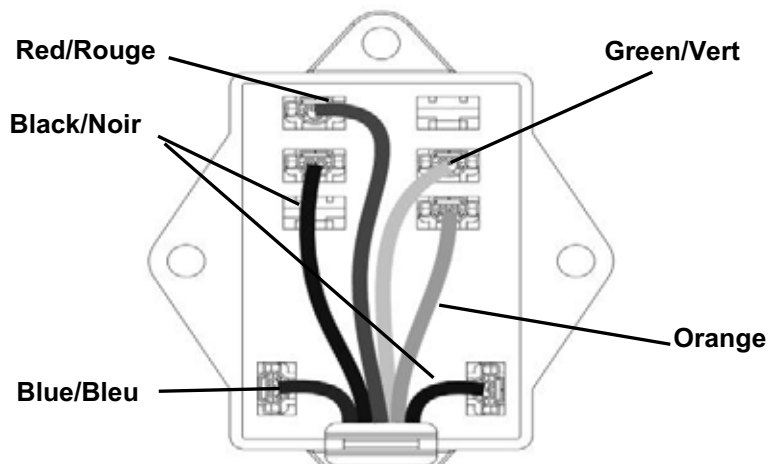

PARTS BREAKDOWN
66" VANTAGE SNOWBLOWER 66" #700512-4-SM

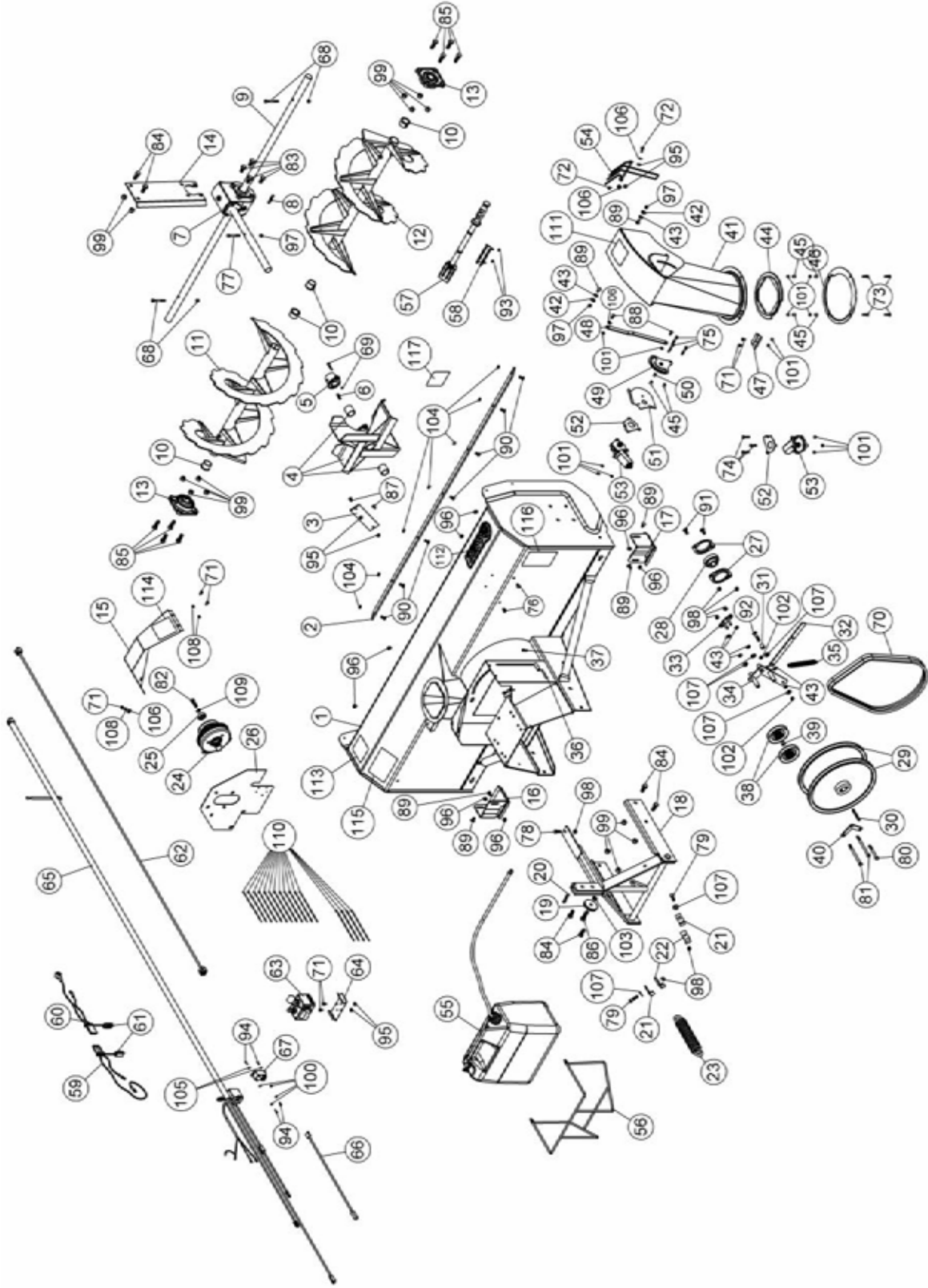

PARTS LIST VANTAGE SNOWBLOWER 66"

Ref. Réf.	English description	Description française	Qty. Qté.	Part # Pièce #
1	Frame 66" with safety decals & cutting edge	Châssis 66" avec décalques de séc. & racloir	1	106698
2	Cutting edge 66"	Racloir 66"	1	105478
3	Reinforcement	Renfort	1	105484
4	Fan with bushing	Éventail avec coussinets	1	106700
5	Shear plate	Plaque de cisaillement	1	106705
6	Key 1/4" x 1/4" x 1 1/4"	Clé 1/4" x 1/4" x 1 1/4"	1	105399
7	Gear box left rotation	Boîte d'engrenage rotation gauche	1	106703
8	Key 1/4" x 1/4" x 2"	Clé 1/4" x 1/4" x 2"	1	102922
9	Shaft 66"	Arbre 66"	1	106339
10	Rotation bushing	Coussinet de rotation	4	106329
11	Auger 66" left	Vis 66" gauche	1	106330
12	Auger 66" right	Vis 66" droite	1	106331
13	Flange Mounted Bearing	Roulement Appliqué	2	106150
14	Gear box support	Support de boîte d'engrenages	1	106706
15	Belt guard with safety decal	Garde-courroie avec décalque de sécurité	1	106702
16	Left skid shoe	Patin gauche	1	105487
17	Right skid shoe	Patin droit	1	105486
18	Hitch	Attache	1	105483
19	Pulley	Poulie	1	106138
20	Lynch pin	Goupille à anneau	1	103919
21	Shim	Cale	2	105489
22	Shim	Cale	2	105490
23	Spring	Ressort	1	105356
24	Electrical Clutch	Embrayage électrique	1	106143
25	Flange washer	Rondelle à bride	1	103976
26	Guard	Garde	1	106268
27	Flangette	Flangette	2	106704
28	Bearing with set screw	Roulement à billes avec vis à pression	1	106371
29	V pulley with set screw	Poulie en V avec vis pression	2	106568
30	Key 1/4" x 1/4" x 2.88"	Clé 1/4" x 1/4" x 2.88"	1	104436

O/L = Obtenir Localement

PARTS LIST VANTAGE SNOWBLOWER 66"

Ref. Réf.	English description	Description française	Qty. Qté.	Part # Pièce #
31	Sleeve	Douille	1	106262
32	Lever	Levier	1	106264
33	Spacer	Espacer	1	106265
34	Bender	Tendeur	1	106701
35	Spring	Ressort	1	102592
36	Pin	Goupille	1	105365
37	Hair pin 2mm	Goupille à ressort 2mm	1	102430
38	V-Pulley	Poulie en V	2	102766
39	Sleeve	Douille	1	106260
40	Retaining Plate	Plaque de retenue	1	106258
41	Chute with safety decal	Goulotte avec decalque de sécurité	1	106707
42	Nylon flat washer 11/32"	Rondelle plate de nylon 11/32"	2	102009
43	Nylon flat washer 7/16"	Rondelle plate de nylon 7/16"	8	102011
44	Rotation ring	Anneau de rotation	1	105429
45	Spacer	Espaceur	6	103361
46	Rotation ring	Anneau de rotation	1	105485
47	Retaining plate	Plaque de retenue	1	105488
48	Arm	Bras	1	106385
49	Lever	Levier	1	103365
50	Oil lite bushing	Coussinet imprégné d'huile	1	103362
51	Bracket	Support	1	105492
52	Gasket	Joint d'étanchéité	2	106570
53	Electric motor	Moteur électrique	2	106147
54	Hand guard	Fourche protectrice	1	105494
55	Gasoline tank assembly	Réservoir d'essence assemblé	1	105524
56	Tank support	Support de réservoir	1	105528
57	Chute shovel	Pelle à goulotte	1	105700
58	Chute shovel support	Support de pelle à goulotte	1	105701
59	Wire assembly	Fil assemblé	1	104017
60	Wire assembly	Fil assemblé	1	104018

O/L = Obtenir Localement

PARTS LIST VANTAGE SNOWBLOWER 66''

Ref. Réf.	English description	Description française	Qty. Qté.	Part # Pièce #
61	Cap	Capuchon	2	105407
62	Wire control box extension	Extension du fil de la boîte de contrôle	1	105400
63	Control box assembly	Boîte de contrôle assemblé	1	106564
64	Box support	Support de la boîte	1	104756
65	Wire Assembly	Fil assemblé	1	106558
66	Wire Assembly	Fil Assemblé	1	106548
67	Relay	Relais	1	106123
68	Shear bolt / N.I.L.N. (auger) pkg-10	Boulon de séc. / É.G.N. (vis) pqt-10	2	106443
69	Shear bolt / N.I.L.N. (fan) pkg-10	Boulon de séc./ É.G.N. (éven.) pqt-10	1	105627
70	Pair of V-belts, BX-54	Paire de courroie en V, BX-54	1	106343
71	Hex. bolt 1/4" n.c. x 1/2" GR5	Boulon hex. 1/4" n.c. x 1/2" GR5	7	O/L
72	Hex. bolt 1/4" n.c. x 3/4" GR5	Boulon hex. 1/4" n.c. x 3/4" GR5	2	O/L
73	Hex. bolt 1/4" n.c. x 1" GR5	Boulon hex. 1/4" n.c. x 1" GR5	4	O/L
74	Hex. bolt 1/4" n.c. x 1 1/4" GR5	Boulon hex. 1/4" n.c. x 1 1/4" GR5	3	O/L
75	Hex. bolt 1/4" n.c. x 1 3/4" GR5	Boulon hex. 1/4" n.c. x 1 3/4" GR5	3	O/L
76	Hex. bolt 5/16" n.c. x 1/2" GR5	Boulon hex. 5/16" n.c. x 1/2" GR5	2	O/L
77	Hex. bolt 5/16" n.c. x 2 1/2" GR5	Boulon hex. 5/16" n.c. x 2 1/2" GR5	1	O/L
78	Hex. bolt 3/8" n.c. x 1" GR5	Boulon hex. 3/8" n.c. x 1" GR5	1	O/L
79	Hex. bolt 3/8" n.c. x 1 1/2" GR5	Boulon hex. 3/8" n.c. x 1 1/2" GR5	2	O/L
80	Hex. bolt 3/8" n.c. x 3 1/4" GR5	Boulon hex. 3/8" n.c. x 3 1/4" GR5	1	O/L
81	Hex. bolt 3/8" n.c. x 5" GR5	Boulon hex. 3/8" n.c. x 5" GR5	2	O/L
82	Hex. bolt 7/16" n.f. x 1 1/2" GR5	Boulon hex. 7/16" n.f. x 1 1/2" GR5	1	O/L
83	Hex. bolt 1/2" n.c. x 1" GR5	Boulon hex. 1/2" n.c. x 1" GR5	4	O/L
84	Hex. bolt 1/2" n.c. x 1 1/4" GR5	Boulon hex. 1/2" n.c. x 1 1/4" GR5	6	O/L
85	Hex. bolt 1/2" n.c. x 1 1/2" GR5	Boulon hex. 1/2" n.c. x 1 1/2" GR5	8	O/L
86	Hex. bolt 1/2" n.c. x 1 3/4" GR5	Boulon hex. 1/2" n.c. x 1 3/4" GR5	1	O/L
87	Carriage bolt 1/4" n.c. x 5/8 " GR5	Boulon à carrosserie 1/4" n.c. x 5/8 " GR5	2	O/L
88	Carriage bolt 1/4" n.c. x 3/4 " GR5	Boulon à carrosserie 1/4" n.c. x 3/4 " GR5	2	O/L
89	Carriage bolt 5/16" n.c. x 3/4 " GR5	Boulon à carrosserie 5/16" n.c. x 3/4 " GR5	6	O/L
90	Carriage bolt 5/16" n.c. x 3/4 " GR5	Boulon à carrosserie 5/16" n.c. x 3/4 " GR5	7	O/L

O/L = Obtenir Localement

PARTS LIST VANTAGE SNOWBLOWER 66"

Ref. Réf.	English description	Description française	Qty. Qté.	Part # Pièce #
91	Carriage bolt 3/8" n.c. x 1 " GR5	Boulon à carrosserie 3/8" n.c. x 1 " GR5	2	O/L
92	Carriage bolt 3/8" n.c. x 2 " GR5	Boulon à carrosserie 3/8" n.c. x 2 " GR5	1	O/L
93	Socket Head Cap Screw M5 x 0.80 x 10	Vis six PC tête ronde M5 x 0.80 x 10	2	O/L
94	Machine screw Pan head no.8 x 32 x 5/8"	Vis mécanique à tête Pan no.8 x 32 x 5/8"	4	O/L
95	Flange nut 1/4" n.c.	Écrou à bride 1/4" n.c.	6	O/L
96	Flange nut 5/16" n.c.	Écrou à bride 5/16" n.c.	8	O/L
97	Nylon Insert lock Nut 5/16" n.c. GR5	Écrou à garniture de nylon 5/16" n.c. GR5	3	O/L
98	Nylon Insert lock Nut 3/8" n.c.	Écrou à garniture de nylon 3/8" n.c.	7	O/L
99	Nylon Insert lock Nut 1/2" n.c.	Écrou à garniture de nylon 1/2" n.c.	14	O/L
100	Nylon insert locknut #8 x 32 (thin) GR2	Écrou à garni. de nylon #8 x 32 (mince) GR2	4	O/L
101	Nylon insert lock nut 1/4" n.c. (thin)	Écrou à garniture de nylon 1/4" n.c. (mince)	14	O/L
102	Nylon insert lock nut 3/8" n.c. (thin)	Écrou à garniture de nylon 3/8" n.c. (mince)	2	O/L
103	Nylon insert lock nut 1/2" n.c. (thin)	Écrou à garniture de nylon 1/2" n.c. (mince)	1	O/L
104	Stover lock nut 5/16" n.c.	Écrou de blocage 5/16" n.c.	7	O/L
105	Flat washer #10 hole	Rondelle plate #10 trou	2	O/L
106	Flat washer 5/16" hole	Rondelle plate 5/16" trou	4	O/L
107	Flat washer 7/16" hole	Rondelle plate 7/16" trou	6	O/L
108	Lock washer 1/4"	Rondelle de blocage 1/4"	3	O/L
109	Lock washer 7/16"	Rondelle de blocage 7/16"	1	O/L
110	Tie wrap 8"	Attache de nylon 8"	16	O/L
111	Danger decal chute	Décalque danger goulotte	1	105127
112	Berco decal	Décalque Berco	1	103785
113	Decal danger auger	Decalque danger vis	1	105126
114	Decal danger belts	Decalque danger courroies	1	105128
115	Decal warning safety	Decalque avertissement sécurité	1	105131
116	Decal read instructions	Decalque lire instructions	1	105130
117	Decal auger positioning	Décalque positionnement vis	1	107024

O/L = Obtenir Localement

PARTS BREAKDOWN

VANTAGE SNOWBLOWER 66" #700512-4-SM-EPA

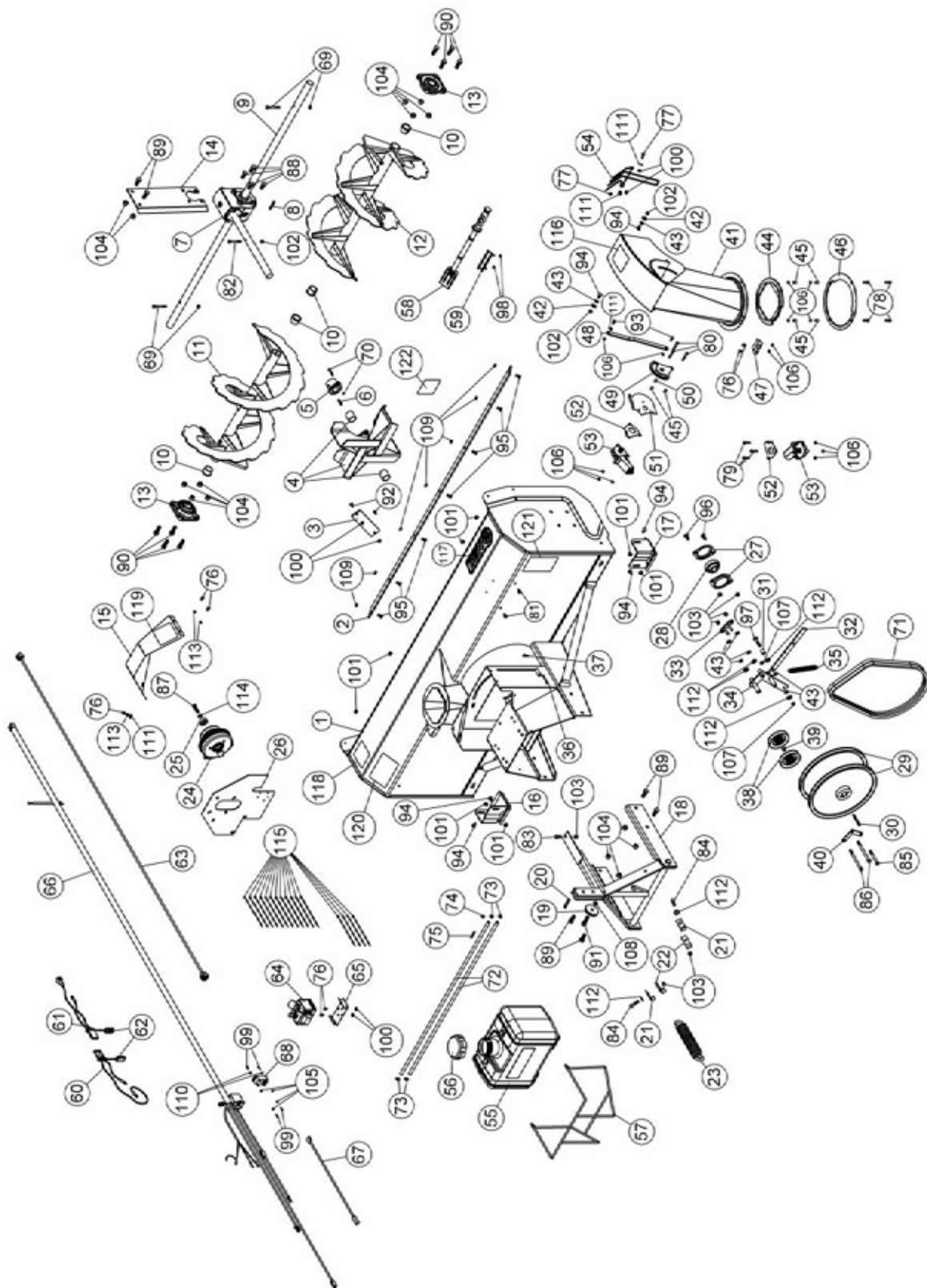

PARTS LIST VANTAGE SNOWBLOWER EPA 66"

Ref. Réf.	English description	Description française	Qty. Qté.	Part # Pièce #
1	Frame 66" with safety decals & cutting	Châssis 66" avec décalques de séc. &	1	106698
2	Cutting edge 66"	Racloir 66"	1	105478
3	Reinforcement	Renfort	1	105484
4	Fan with bushing	Éventail avec coussinets	1	106700
5	Shear plate	Plaque de cisaillement	1	106705
6	Key 1/4" x 1/4" x 1 1/4"	Clé 1/4" x 1/4" x 1 1/4"	1	105399
7	Gear box left rotation	Boîte d'engrenage rotation gauche	1	106703
8	Key 1/4" x 1/4" x 2"	Clé 1/4" x 1/4" x 2"	1	102922
9	Shaft 66"	Arbre 66"	1	106339
10	Rotation bushing	Coussinet de rotation	4	106329
11	Auger 66" left	Vis 66" gauche	1	106330
12	Auger 66" right	Vis 66" droite	1	106331
13	Flange Mounted Bearing	Roulement Appliqué	2	106150
14	Gear box support	Support de boîte d'engrenages	1	106706
15	Belt guard with safety decal	Garde-courroie avec décalque de sécurité	1	106702
16	Left skid shoe	Patin gauche	1	105487
17	Right skid shoe	Patin droit	1	105486
18	Hitch	Attache	1	105483
19	Pulley	Poulie	1	106138
20	Lynch pin	Goupille à anneau	1	103919
21	Shim	Cale	2	105489
22	Shim	Cale	2	105490
23	Spring	Ressort	1	105356
24	Electrical Clutch	Embrayage électrique	1	106143
25	Flange washer	Rondelle à bride	1	103976
26	Guard	Garde	1	106268
27	Flangette	Flangette	2	106704
28	Bearing with set screw	Roulement à billes avec vis à pression	1	106371
29	V pulley with set screw	Poulie en V avec vis pression	2	106568
30	Key 1/4" x 1/4" x 2.88"	Clé 1/4" x 1/4" x 2.88"	1	104436

O/L = Obtenir Localement

PARTS LIST VANTAGE SNOWBLOWER EPA 66''

Ref. Réf.	English description	Description française	Qty. Qté.	Part # Pièce #
31	Sleeve	Douille	1	106262
32	Lever	Levier	1	106264
33	Spacer	Espaceur	1	106265
34	Bender	Tendeur	1	106701
35	Spring	Ressort	1	102592
36	Pin	Goupille	1	105365
37	Hair pin 2mm	Goupille à ressort 2mm	1	102430
38	V-Pulley	Poulie en V	2	102766
39	Sleeve	Douille	1	106260
40	Retaining Plate	Plaque de retenue	1	106258
41	Chute with safety decal	Goulotte avec decalque de sécurité	1	106707
42	Nylon flat washer 11/32"	Rondelle plate de nylon 11/32"	2	102009
43	Nylon flat washer 7/16"	Rondelle plate de nylon 7/16"	8	102011
44	Rotation ring	Anneau de rotation	1	105429
45	Spacer	Espaceur	6	103361
46	Rotation ring	Anneau de rotation	1	105485
47	Retaining plate	Plaque de retenue	1	105488
48	Arm	Bras	1	106385
49	Lever	Levier	1	103365
50	Oil lite bushing	Coussinet imprégné d'huile	1	103362
51	Bracket	Support	1	105492
52	Gasket	Joint d'étanchéité	2	106570
53	Electric motor	Moteur électrique	2	106147
54	Hand guard	Fourche protectrice	1	105494
55	5 Gallon EPA gasoline tank	Réservoir à essence 5 gallon EPA	1	107311
56	Gasoline tank cap	Bouchon de réservoir à essence	1	107312
57	Tank support	Support de réservoir	1	105528
58	Chute shovel	Pelle à goulotte	1	105700
59	Chute shovel support	Support de pelle à goulotte	1	105701
60	Wire assembly	Fil assemblé	1	104017

O/L = Obtenir Localement

PARTS LIST VANTAGE SNOWBLOWER EPA 66''

Ref. Réf.	English description	Description française	Qty. Qté.	Part # Pièce #
61	Wire assembly	Fil assemblé	1	104018
62	Cap	Capuchon	2	105407
63	Wire control box extension	Extension du fil de la boîte de contrôle	1	105400
64	Control box assembly	Boîte de contrôle assemblé	1	106564
65	Box support	Support de la boîte	1	104756
66	Wire Assembly	Fil assemblé	1	106558
67	Wire Assembly	Fil Assemblé	1	106548
68	Relay	Relais	1	106123
69	Shear bolt / N.I.L.N. (auger) pkg-10	Boulon de séc. / É.G.N. (vis) pqt-10	2	106443
70	Shear bolt / N.I.L.N. (fan) pkg-10	Boulon de séc./ É.G.N. (éven.) pqt-10	1	105627
71	Pair of V-belts, BX-54	Paire de courroie en V, BX-54	1	106343
72	Fuel hose EPA 1/4"	Tuyau à essence EPA 1/4"	2	107308
73	Spring action hose clamp for 1/2" hose	Collier de serrage à ressort pour tuyau 1/2"	4	107269
74	Spring action hose clamp for 7/16" hose	Collier de serrage à ressort pour tuyau 7/16"	1	107310
75	Barb adapter 1/4" x 3/16"	Adaptateur à barbillon 1/4" x 3/16"	1	107319
76	Hex. bolt 1/4" n.c. x 1/2" GR5	Boulon hex. 1/4" n.c. x 1/2" GR5	7	O/L
77	Hex. bolt 1/4" n.c. x 3/4" GR5	Boulon hex. 1/4" n.c. x 3/4" GR5	2	O/L
78	Hex. bolt 1/4" n.c. x 1" GR5	Boulon hex. 1/4" n.c. x 1" GR5	4	O/L
79	Hex. bolt 1/4" n.c. x 1 1/4" GR5	Boulon hex. 1/4" n.c. x 1 1/4" GR5	3	O/L
80	Hex. bolt 1/4" n.c. x 1 3/4" GR5	Boulon hex. 1/4" n.c. x 1 3/4" GR5	3	O/L
81	Hex. bolt 5/16" n.c. x 1/2" GR5	Boulon hex. 5/16" n.c. x 1/2" GR5	2	O/L
82	Hex. bolt 5/16" n.c. x 2 1/2" GR5	Boulon hex. 5/16" n.c. x 2 1/2" GR5	1	O/L
83	Hex. bolt 3/8" n.c. x 1" GR5	Boulon hex. 3/8" n.c. x 1" GR5	1	O/L
84	Hex. bolt 3/8" n.c. x 1 1/2" GR5	Boulon hex. 3/8" n.c. x 1 1/2" GR5	2	O/L
85	Hex. bolt 3/8" n.c. x 3 1/4" GR5	Boulon hex. 3/8" n.c. x 3 1/4" GR5	1	O/L
86	Hex. bolt 3/8" n.c. x 5" GR5	Boulon hex. 3/8" n.c. x 5" GR5	2	O/L
87	Hex. bolt 7/16" n.f. x 1 1/2" GR5	Boulon hex. 7/16" n.f. x 1 1/2" GR5	1	O/L
88	Hex. bolt 1/2" n.c. x 1" GR5	Boulon hex. 1/2" n.c. x 1" GR5	4	O/L
89	Hex. bolt 1/2" n.c. x 1 1/4" GR5	Boulon hex. 1/2" n.c. x 1 1/4" GR5	6	O/L
90	Hex. bolt 1/2" n.c. x 1 1/2" GR5	Boulon hex. 1/2" n.c. x 1 1/2" GR5	8	O/L

O/L = Obtenir Localement

PARTS LIST

VANTAGE SNOWBLOWER EPA 66''

Ref. Réf.	English description	Description française	Qty. Qté.	Part # Pièce #
91	Hex. bolt 1/2" n.c. x 1 3/4" GR5	Boulon hex. 1/2" n.c. x 1 3/4" GR5	1	O/L
92	Carriage bolt 1/4" n.c. x 5/8 " GR5	Boulon à carrosserie 1/4" n.c. x 5/8 " GR5	2	O/L
93	Carriage bolt 1/4" n.c. x 3/4 " GR5	Boulon à carrosserie 1/4" n.c. x 3/4" GR5	2	O/L
94	Carriage bolt 5/16" n.c. x 3/4 " GR5	Boulon à carrosserie 5/16" n.c. x 3/4 " GR5	6	O/L
95	Carriage bolt 5/16" n.c. x 3/4 " GR5	Boulon à carrosserie 5/16" n.c. x 3/4 " GR5	7	O/L
96	Carriage bolt 3/8" n.c. x 1 " GR5	Boulon à carrosserie 3/8" n.c. x 1 " GR5	2	O/L
97	Carriage bolt 3/8" n.c. x 2 " GR5	Boulon à carrosserie 3/8" n.c. x 2 " GR5	1	O/L
98	Socket Head Cap Screw M5 x 0.80 x 10	Vis six PC tête ronde M5 x 0.80 x 10	2	O/L
99	Machine screw Pan head no.8 x 32 x 5/8"	Vis mécanique à tête Pan no.8 x 32 x 5/8"	4	O/L
100	Flange nut 1/4" n.c.	Écrou à bride 1/4" n.c.	6	O/L
101	Flange nut 5/16" n.c.	Écrou à bride 5/16" n.c.	8	O/L
102	Nylon Insert lock Nut 5/16" n.c. GR5	Écrou à garniture de nylon 5/16" n.c. GR5	3	O/L
103	Nylon Insert lock Nut 3/8" n.c.	Écrou à garniture de nylon 3/8" n.c.	7	O/L
104	Nylon Insert lock Nut 1/2" n.c.	Écrou à garniture de nylon 1/2" n.c.	14	O/L
105	Nylon insert locknut #8 x 32 (thin) GR2	Écrou à garni. de nylon #8 x 32 (mince) GR2	4	O/L
106	Nylon insert lock nut 1/4" n.c. (thin)	Écrou à garniture de nylon 1/4" n.c. (mince)	14	O/L
107	Nylon insert lock nut 3/8" n.c. (thin)	Écrou à garniture de nylon 3/8" n.c. (mince)	2	O/L
108	Nylon insert lock nut 1/2" n.c. (thin)	Écrou à garniture de nylon 1/2" n.c. (mince)	1	O/L
109	Stover lock nut 5/16" n.c.	Écrou de blocage 5/16" n.c.	7	O/L
110	Flat washer #10 hole	Rondelle plate #10 trou	2	O/L
111	Flat washer 5/16" hole	Rondelle plate 5/16" trou	4	O/L
112	Flat washer 7/16" hole	Rondelle plate 7/16" trou	6	O/L
113	Lock washer 1/4"	Rondelle de blocage 1/4"	3	O/L
114	Lock washer 7/16"	Rondelle de blocage 7/16"	1	O/L
115	Tie wrap 8"	Attache de nylon 8"	16	O/L
116	Danger decal chute	Décalque danger goulotte	1	105127
117	Berco decal	Décalque Berco	1	103785
118	Decal danger auger	Decalque danger vis	1	105126
119	Decal danger belts	Decalque danger courroies	1	105128
120	Decal warning safety	Decalque avertissement sécurité	1	105131
121	Decal read instructions	Decalque lire instructions	1	105130
122	Decal auger positioning	Décalque positionnement vis	1	107024

O/L = Obtenir Localement

PARTS BREAKDOWN

VANTAGE SNOWBLOWER 72" #700513-4-SM

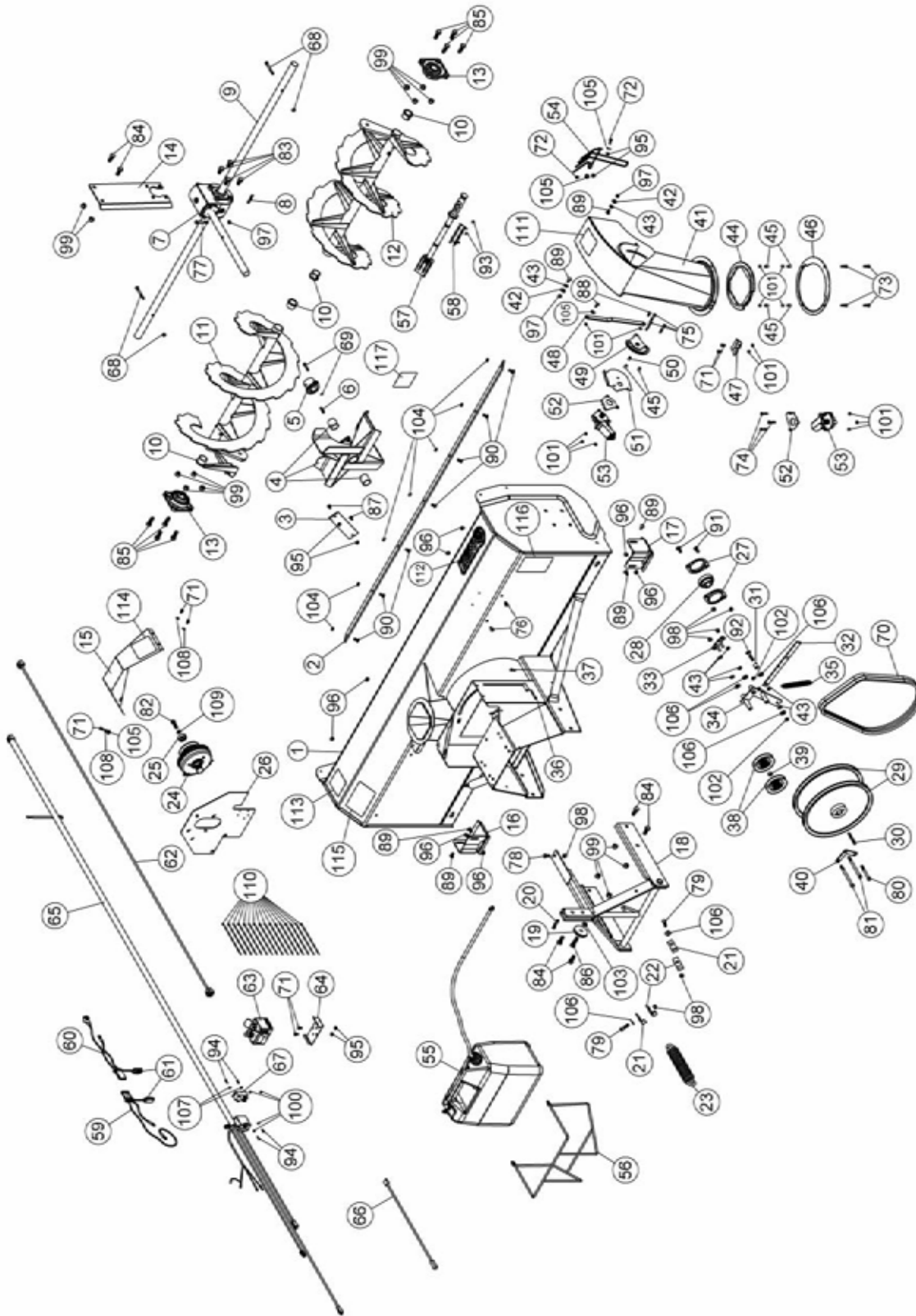

PARTS LIST VANTAGE SNOWBLOWER 72"

Ref. Réf.	English description	Description française	Qty. Qté.	Part # Pièce #
1	Frame 72" with safety decals & cutting edge	Châssis 72" avec décalques de séc. & racloir	1	106709
2	Cutting edge 72"	Racloir 72"	1	105479
3	Reinforcement	Renfort	1	105484
4	Fan with bushing	Éventail avec coussinets	1	106700
5	Shear plate	Plaque de cisaillement	1	106705
6	Key 1/4" x 1/4" x 1 1/4"	Clé 1/4" x 1/4" x 1 1/4"	1	105399
7	Gear box left rotation	Boîte d'engrenage rotation gauche	1	106703
8	Key 1/4" x 1/4" x 2"	Clé 1/4" x 1/4" x 2"	1	102922
9	Shaft 72"	Arbre 72"	1	106710
10	Rotation bushing	Coussinet de rotation	4	106329
11	Auger 72" left	Vis 72" gauche	1	106672
12	Auger 72" right	Vis 72" droite	1	106673
13	Flange Mounted Bearing	Roulement Appliqué	2	106150
14	Gear box support	Support de boîte d'engrenages	1	106706
15	Belt guard with safety decal	Garde-courroie avec décalque de sécurité	1	106702
16	Left skid shoe	Patin gauche	1	105487
17	Right skid shoe	Patin droit	1	105486
18	Hitch	Attache	1	105483
19	Pulley	Poulie	1	106138
20	Lynch pin	Goupille à anneau	1	103919
21	Shim	Cale	2	105489
22	Shim	Cale	2	105490
23	Spring	Ressort	1	105356
24	Electrical Clutch	Embrayage électrique	1	106143
25	Flange washer	Rondelle à bride	1	103976
26	Guard	Garde	1	106268
27	Flangette	Flangette	2	106704
28	Bearing with set screw	Roulement à billes avec vis à pression	1	106371
29	V pulley with set screw	Poulie en V avec vis pression	2	106568
30	Key 1/4" x 1/4" x 2.88"	Clé 1/4" x 1/4" x 2.88"	1	104436

O/L = Obtain Locally

PARTS LIST VANTAGE SNOWBLOWER 72"

Ref. Réf.	English description	Description française	Qty. Qté.	Part # Pièce #
31	Sleeve	Douille	1	106262
32	Lever	Levier	1	106264
33	Spacer	Espacer	1	106265
34	Bender	Tendeur	1	106701
35	Spring	Ressort	1	102592
36	Pin	Goupille	1	105365
37	Hair pin 2mm	Goupille à ressort 2mm	1	102430
38	V-Pulley	Poulie en V	2	102766
39	Sleeve	Douille	1	106260
40	Retaining Plate	Plaque de retenue	1	106258
41	Chute with safety decal	Goulotte avec decalque de sécurité	1	106707
42	Nylon flat washer 11/32"	Rondelle plate de nylon 11/32"	2	102009
43	Nylon flat washer 7/16"	Rondelle plate de nylon 7/16"	8	102011
44	Rotation ring	Anneau de rotation	1	105429
45	Spacer	Espaceur	6	103361
46	Rotation ring	Anneau de rotation	1	105485
47	Retaining plate	Plaque de retenue	1	105488
48	Arm	Bras	1	106385
49	Lever	Levier	1	103365
50	Oil lite bushing	Coussinet imprégné d'huile	1	103362
51	Bracket	Support	1	105492
52	Gasket	Joint d'étanchéité	2	106570
53	Electric motor	Moteur électrique	2	106147
54	Hand guard	Fourche protectrice	1	105494
55	Gasoline tank assembly	Réservoir d'essence assemblé	1	105524
56	Tank support	Support de réservoir	1	105528
57	Chute shovel	Pelle à goulotte	1	105700
58	Chute shovel support	Support de pelle à goulotte	1	105701
59	Wire assembly	Fil assemblé	1	104017
60	Wire assembly	Fil assemblé	1	104018

O/L = Obtain Locally

PARTS LIST VANTAGE SNOWBLOWER 72"

Ref. Réf.	English description	Description française	Qty. Qté.	Part # Pièce #
61	Cap	Capuchon	2	105407
62	Wire control box extension	Extension du fil de la boîte de contrôle	1	105400
63	Control box assembly	Boîte de contrôle assemblé	1	106564
64	Box support	Support de la boîte	1	104756
65	Wire Assembly	Fil assemblé	1	106558
66	Wire Assembly	Fil Assemblé	1	106548
67	Relay	Relais	1	106123
68	Shear bolt / N.I.L.N. (auger) pkg-10	Boulon de séc. / É.G.N. (vis) pqt-10	2	106443
69	Shear bolt / N.I.L.N. (fan) pkg-10	Boulon de séc./ É.G.N. (éven.) pqt-10	1	105627
70	Pair of V-belts, BX-54	Paire de courroie en V, BX-54	1	106343
71	Hex. bolt 1/4" n.c. x 1/2" GR5	Boulon hex. 1/4" n.c. x 1/2" GR5	7	O/L
72	Hex. bolt 1/4" n.c. x 3/4" GR5	Boulon hex. 1/4" n.c. x 3/4" GR5	2	O/L
73	Hex. bolt 1/4" n.c. x 1" GR5	Boulon hex. 1/4" n.c. x 1" GR5	4	O/L
74	Hex. bolt 1/4" n.c. x 1 1/4" GR5	Boulon hex. 1/4" n.c. x 1 1/4" GR5	3	O/L
75	Hex. bolt 1/4" n.c. x 1 3/4" GR5	Boulon hex. 1/4" n.c. x 1 3/4" GR5	3	O/L
76	Hex. bolt 5/16" n.c. x 1/2" GR5	Boulon hex. 5/16" n.c. x 1/2" GR5	2	O/L
77	Hex. bolt 5/16" n.c. x 2 1/2" GR5	Boulon hex. 5/16" n.c. x 2 1/2" GR5	1	O/L
78	Hex. bolt 3/8" n.c. x 1" GR5	Boulon hex. 3/8" n.c. x 1" GR5	1	O/L
79	Hex. bolt 3/8" n.c. x 1 1/2" GR5	Boulon hex. 3/8" n.c. x 1 1/2" GR5	2	O/L
80	Hex. bolt 3/8" n.c. x 3 1/4" GR5	Boulon hex. 3/8" n.c. x 3 1/4" GR5	1	O/L
81	Hex. bolt 3/8" n.c. x 5" GR5	Boulon hex. 3/8" n.c. x 5" GR5	2	O/L
82	Hex. bolt 7/16" n.f. x 1 1/2" GR5	Boulon hex. 7/16" n.f. x 1 1/2" GR5	1	O/L
83	Hex. bolt 1/2" n.c. x 1" GR5	Boulon hex. 1/2" n.c. x 1" GR5	4	O/L
84	Hex. bolt 1/2" n.c. x 1 1/4" GR5	Boulon hex. 1/2" n.c. x 1 1/4" GR5	6	O/L
85	Hex. bolt 1/2" n.c. x 1 1/2" GR5	Boulon hex. 1/2" n.c. x 1 1/2" GR5	8	O/L
86	Hex. bolt 1/2" n.c. x 1 3/4" GR5	Boulon hex. 1/2" n.c. x 1 3/4" GR5	1	O/L
87	Carriage bolt 1/4" n.c. x 5/8 " GR5	Boulon à carrosserie 1/4" n.c. x 5/8 " GR5	2	O/L
88	Carriage bolt 1/4" n.c. x 3/4 " GR5	Boulon à carrosserie 1/4" n.c. x 3/4" GR5	2	O/L
89	Carriage bolt 5/16" n.c. x 3/4 " GR5	Boulon à carrosserie 5/16" n.c. x 3/4 " GR5	6	O/L
90	Carriage bolt 5/16" n.c. x 3/4 " GR5	Boulon à carrosserie 5/16" n.c. x 3/4 " GR5	7	O/L

O/L = Obtain Locally

PARTS LIST VANTAGE SNOWBLOWER 72"

Ref. Réf.	English description	Description française	Qty. Qté.	Part # Pièce #
91	Carriage bolt 3/8" n.c. x 1 " GR5	Boulon à carrosserie 3/8" n.c. x 1 " GR5	2	O/L
92	Carriage bolt 3/8" n.c. x 2 " GR5	Boulon à carrosserie 3/8" n.c. x 2 " GR5	1	O/L
93	Socket Head Cap Screw M5 x 0.80 x 10	Vis six PC tête ronde M5 x 0.80 x 10	2	O/L
94	Machine screw Pan head no.8 x 32 x 5/8"	Vis mécanique à tête Pan no.8 x 32 x 5/8"	4	O/L
95	Flange nut 1/4" n.c.	Écrou à bride 1/4" n.c.	6	O/L
96	Flange nut 5/16" n.c.	Écrou à bride 5/16" n.c.	8	O/L
97	Nylon Insert lock Nut 5/16" n.c. GR5	Écrou à garniture de nylon 5/16" n.c. GR5	3	O/L
98	Nylon Insert lock Nut 3/8" n.c.	Écrou à garniture de nylon 3/8" n.c.	7	O/L
99	Nylon Insert lock Nut 1/2" n.c.	Écrou à garniture de nylon 1/2" n.c.	14	O/L
100	Nylon insert locknut #8 x 32 (thin) GR2	Écrou à garni. de nylon #8 x 32 (mince) GR2	4	O/L
101	Nylon insert lock nut 1/4" n.c. (thin)	Écrou à garniture de nylon 1/4" n.c. (mince)	14	O/L
102	Nylon insert lock nut 3/8" n.c. (thin)	Écrou à garniture de nylon 3/8" n.c. (mince)	2	O/L
103	Nylon insert lock nut 1/2" n.c. (thin)	Écrou à garniture de nylon 1/2" n.c. (mince)	1	O/L
104	Stover lock nut 5/16" n.c.	Écrou de blocage 5/16" n.c.	7	O/L
105	Flat washer 5/16" hole	Rondelle plate 5/16" trou	4	O/L
106	Flat washer 7/16" hole	Rondelle plate 7/16" trou	6	O/L
107	Flat washer #10 hole	Rondelle plate #10 trou	2	O/L
108	Lock washer 1/4"	Rondelle de blocage 1/4"	3	O/L
109	Lock washer 7/16"	Rondelle de blocage 7/16"	1	O/L
110	Tie wrap 8"	Attache de nylon 8"	16	O/L
111	Danger decal chute	Décalque danger goulotte	1	105127
112	Berco decal	Décalque Berco	1	103785
113	Decal danger auger	Decalque danger vis	1	105126
114	Decal danger belts	Decalque danger courroies	1	105128
115	Decal warning safety	Decalque avertissement sécurité	1	105131
116	Decal read instructions	Decalque lire instructions	1	105130
117	Decal auger positioning	Décalque positionnement vis	1	107024

O/L = Obtain Locally

PARTS BREAKDOWN

VANTAGE SNOWBLOWER 72" #700513-4-SM-EPA

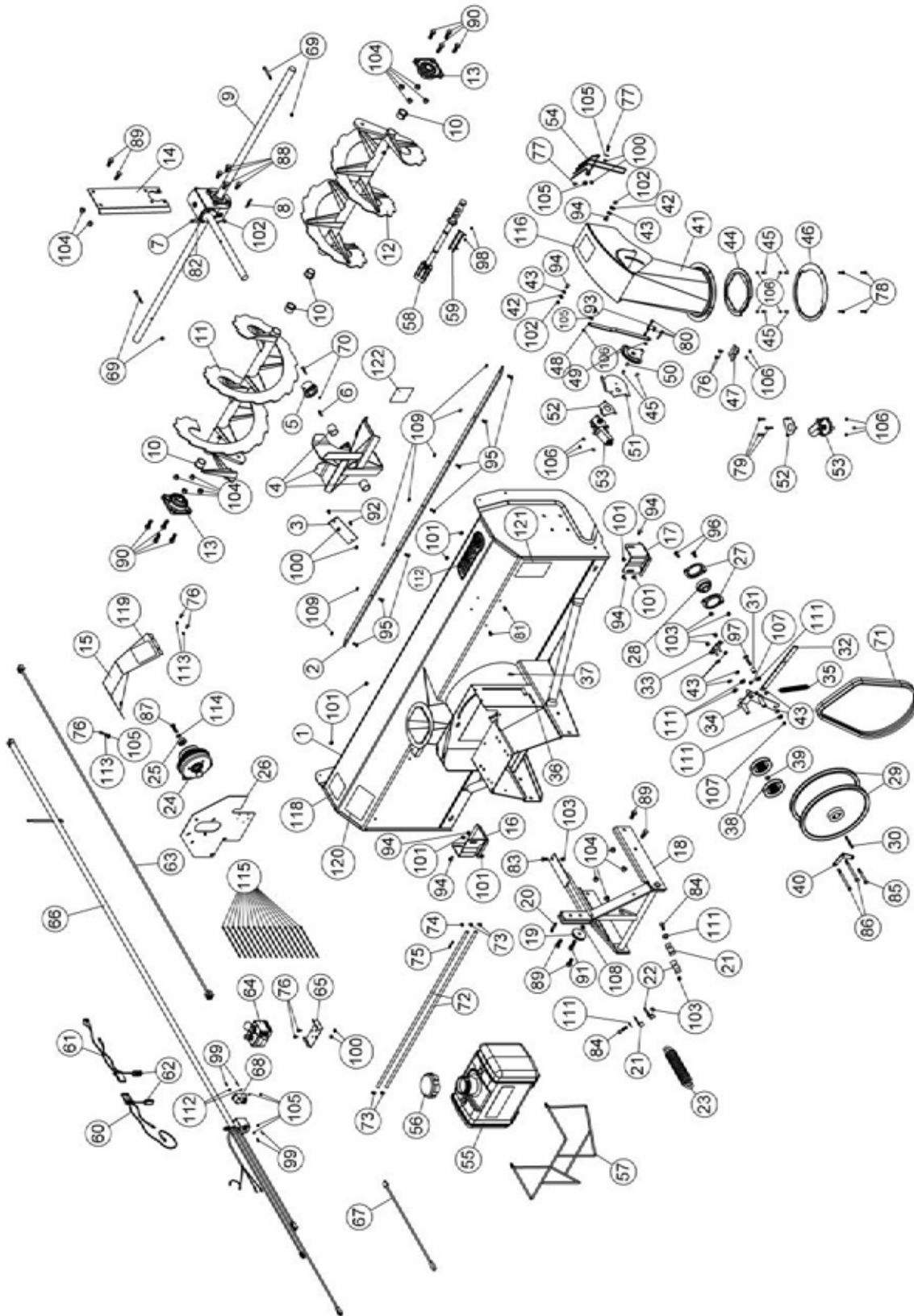

PARTS LIST VANTAGE SNOWBLOWER EPA 72''

Ref. Réf.	English description	Description française	Qty. Qté.	Part # Pièce #
1	Frame 72" with safety decals & cutting edge	Châssis 72" avec décalques de séc. & racloir	1	106709
2	Cutting edge 72"	Racloir 72"	1	105479
3	Reinforcement	Renfort	1	105484
4	Fan with bushing	Éventail avec coussinets	1	106700
5	Shear plate	Plaque de cisaillement	1	106705
6	Key 1/4" x 1/4" x 1 1/4"	Clé 1/4" x 1/4" x 1 1/4"	1	105399
7	Gear box left rotation	Boîte d'engrenage rotation gauche	1	106703
8	Key 1/4" x 1/4" x 2"	Clé 1/4" x 1/4" x 2"	1	102922
9	Shaft 72"	Arbre 72"	1	106710
10	Rotation bushing	Coussinet de rotation	4	106329
11	Auger 72" left	Vis 72" gauche	1	106672
12	Auger 72" right	Vis 72" droite	1	106673
13	Flange Mounted Bearing	Roulement Appliqué	2	106150
14	Gear box support	Support de boîte d'engrenages	1	106706
15	Belt guard with safety decal	Garde-courroie avec décalque de sécurité	1	106702
16	Left skid shoe	Patin gauche	1	105487
17	Right skid shoe	Patin droit	1	105486
18	Hitch	Attache	1	105483
19	Pulley	Poulie	1	106138
20	Lynch pin	Goupille à anneau	1	103919
21	Shim	Cale	2	105489
22	Shim	Cale	2	105490
23	Spring	Ressort	1	105356
24	Electrical Clutch	Embrayage électrique	1	106143
25	Flange washer	Rondelle à bride	1	103976
26	Guard	Garde	1	106268
27	Flangette	Flangette	2	106704
28	Bearing with set screw	Roulement à billes avec vis à pression	1	106371
29	V pulley with set screw	Poulie en V avec vis pression	2	106568
30	Key 1/4" x 1/4" x 2.88"	Clé 1/4" x 1/4" x 2.88"	1	104436

O/L = Obtain Locally

PARTS LIST VANTAGE SNOWBLOWER EPA 72"

Ref. Réf.	English description	Description française	Qty. Qté.	Part # Pièce #
31	Sleeve	Douille	1	106262
32	Lever	Levier	1	106264
33	Spacer	Espacer	1	106265
34	Bender	Tendeur	1	106701
35	Spring	Ressort	1	102592
36	Pin	Goupille	1	105365
37	Hair pin 2mm	Goupille à ressort 2mm	1	102430
38	V-Pulley	Poulie en V	2	102766
39	Sleeve	Douille	1	106260
40	Retaining Plate	Plaque de retenue	1	106258
41	Chute with safety decal	Goulotte avec decalque de sécurité	1	106707
42	Nylon flat washer 11/32"	Rondelle plate de nylon 11/32"	2	102009
43	Nylon flat washer 7/16"	Rondelle plate de nylon 7/16"	8	102011
44	Rotation ring	Anneau de rotation	1	105429
45	Spacer	Espaceur	6	103361
46	Rotation ring	Anneau de rotation	1	105485
47	Retaining plate	Plaque de retenue	1	105488
48	Arm	Bras	1	106385
49	Lever	Levier	1	103365
50	Oil lite bushing	Coussinet imprégné d'huile	1	103362
51	Bracket	Support	1	105492
52	Gasket	Joint d'étanchéité	2	106570
53	Electric motor	Moteur électrique	2	106147
54	Hand guard	Fourche protectrice	1	105494
55	5 Gallon EPA gasoline tank	Réservoir à essence 5 gallon EPA	1	107311
56	Gasoline tank cap	Bouchon de réservoir à essence	1	107312
57	Tank support	Support de réservoir	1	105528
58	Chute shovel	Pelle à goulotte	1	105700
59	Chute shovel support	Support de pelle à goulotte	1	105701
60	Wire assembly	Fil assemblé	1	104017

O/L = Obtain Locally

PARTS LIST VANTAGE SNOWBLOWER EPA 72"

Ref. Réf.	English description	Description française	Qty. Qté.	Part # Pièce #
61	Wire assembly	Fil assemblé	1	104018
62	Cap	Capuchon	2	105407
63	Wire control box extension	Extension du fil de la boîte de contrôle	1	105400
64	Control box assembly	Boîte de contrôle assemblé	1	106564
65	Box support	Support de la boîte	1	104756
66	Wire Assembly	Fil assemblé	1	106558
67	Wire Assembly	Fil Assemblé	1	106548
68	Relay	Relais	1	106123
69	Shear bolt / N.I.L.N. (auger) pkg-10	Boulon de séc. / É.G.N. (vis) pqt-10	2	106443
70	Shear bolt / N.I.L.N. (fan) pkg-10	Boulon de séc./ É.G.N. (éven.) pqt-10	1	105627
71	Pair of V-belts, BX-54	Paire de courroie en V, BX-54	1	106343
72	Fuel hose EPA 1/4"	Tuyau à essence EPA 1/4"	2	107308
73	Spring action hose clamp for 1/2" hose	Collier de serrage à ressort pour tuyau 1/2"	4	107269
74	Spring action hose clamp for 7/16" hose	Collier de serrage à ressort pour tuyau 7/16"	1	107310
75	Barb adapter 1/4" x 3/16"	Adaptateur à barbillon 1/4" x 3/16"	1	107319
76	Hex. bolt 1/4" n.c. x 1/2" GR5	Boulon hex. 1/4" n.c. x 1/2" GR5	7	O/L
77	Hex. bolt 1/4" n.c. x 3/4" GR5	Boulon hex. 1/4" n.c. x 3/4" GR5	2	O/L
78	Hex. bolt 1/4" n.c. x 1" GR5	Boulon hex. 1/4" n.c. x 1" GR5	4	O/L
79	Hex. bolt 1/4" n.c. x 1 1/4" GR5	Boulon hex. 1/4" n.c. x 1 1/4" GR5	3	O/L
80	Hex. bolt 1/4" n.c. x 1 3/4" GR5	Boulon hex. 1/4" n.c. x 1 3/4" GR5	3	O/L
81	Hex. bolt 5/16" n.c. x 1/2" GR5	Boulon hex. 5/16" n.c. x 1/2" GR5	2	O/L
82	Hex. bolt 5/16" n.c. x 2 1/2" GR5	Boulon hex. 5/16" n.c. x 2 1/2" GR5	1	O/L
83	Hex. bolt 3/8" n.c. x 1" GR5	Boulon hex. 3/8" n.c. x 1" GR5	1	O/L
84	Hex. bolt 3/8" n.c. x 1 1/2" GR5	Boulon hex. 3/8" n.c. x 1 1/2" GR5	2	O/L
85	Hex. bolt 3/8" n.c. x 3 1/4" GR5	Boulon hex. 3/8" n.c. x 3 1/4" GR5	1	O/L
86	Hex. bolt 3/8" n.c. x 5" GR5	Boulon hex. 3/8" n.c. x 5" GR5	2	O/L
87	Hex. bolt 7/16" n.f. x 1 1/2" GR5	Boulon hex. 7/16" n.f. x 1 1/2" GR5	1	O/L
88	Hex. bolt 1/2" n.c. x 1" GR5	Boulon hex. 1/2" n.c. x 1" GR5	4	O/L
89	Hex. bolt 1/2" n.c. x 1 1/4" GR5	Boulon hex. 1/2" n.c. x 1 1/4" GR5	6	O/L
90	Hex. bolt 1/2" n.c. x 1 1/2" GR5	Boulon hex. 1/2" n.c. x 1 1/2" GR5	8	O/L

O/L = Obtain Locally

PARTS LIST VANTAGE SNOWBLOWER EPA 72"

Ref. Réf.	English description	Description française	Qty. Qté.	Part # Pièce #
91	Hex. bolt 1/2" n.c. x 1 3/4" GR5	Boulon hex. 1/2" n.c. x 1 3/4" GR5	1	O/L
92	Carriage bolt 1/4" n.c. x 5/8 " GR5	Boulon à carrosserie 1/4" n.c. x 5/8 " GR5	2	O/L
93	Carriage bolt 1/4" n.c. x 3/4 " GR5	Boulon à carrosserie 1/4" n.c. x 3/4" GR5	2	O/L
94	Carriage bolt 5/16" n.c. x 3/4 " GR5	Boulon à carrosserie 5/16" n.c. x 3/4 " GR5	6	O/L
95	Carriage bolt 5/16" n.c. x 3/4 " GR5	Boulon à carrosserie 5/16" n.c. x 3/4 " GR5	7	O/L
96	Carriage bolt 3/8" n.c. x 1 " GR5	Boulon à carrosserie 3/8" n.c. x 1 " GR5	2	O/L
97	Carriage bolt 3/8" n.c. x 2 " GR5	Boulon à carrosserie 3/8" n.c. x 2 " GR5	1	O/L
98	Socket Head Cap Screw M5 x 0.80 x 10	Vis six PC tête ronde M5 x 0.80 x 10	2	O/L
99	Machine screw Pan head no.8 x 32 x 5/8"	Vis mécanique à tête Pan no.8 x 32 x 5/8"	4	O/L
100	Flange nut 1/4" n.c.	Écrou à bride 1/4" n.c.	6	O/L
101	Flange nut 5/16" n.c.	Écrou à bride 5/16" n.c.	8	O/L
102	Nylon Insert lock Nut 5/16" n.c. GR5	Écrou à garniture de nylon 5/16" n.c. GR5	3	O/L
103	Nylon Insert lock Nut 3/8" n.c.	Écrou à garniture de nylon 3/8" n.c.	7	O/L
104	Nylon Insert lock Nut 1/2" n.c.	Écrou à garniture de nylon 1/2" n.c.	14	O/L
105	Nylon insert locknut #8 x 32 (thin) GR2	Écrou à garni. de nylon #8 x 32 (mince) GR2	4	O/L
106	Nylon insert lock nut 1/4" n.c. (thin)	Écrou à garniture de nylon 1/4" n.c. (mince)	14	O/L
107	Nylon insert lock nut 3/8" n.c. (thin)	Écrou à garniture de nylon 3/8" n.c. (mince)	2	O/L
108	Nylon insert lock nut 1/2" n.c. (thin)	Écrou à garniture de nylon 1/2" n.c. (mince)	1	O/L
109	Stover lock nut 5/16" n.c.	Écrou de blocage 5/16" n.c.	7	O/L
105	Flat washer 5/16" hole	Rondelle plate 5/16" trou	4	O/L
111	Flat washer 7/16" hole	Rondelle plate 7/16" trou	6	O/L
112	Flat washer #10 hole	Rondelle plate #10 trou	2	O/L
113	Lock washer 1/4"	Rondelle de blocage 1/4"	3	O/L
114	Lock washer 7/16"	Rondelle de blocage 7/16"	1	O/L
115	Tie wrap 8"	Attache de nylon 8"	16	O/L
116	Danger decal chute	Décalque danger goulotte	1	105127
112	Berco decal	Décalque Berco	1	103785
118	Decal danger auger	Decalque danger vis	1	105126
119	Decal danger belts	Decalque danger courroies	1	105128
120	Decal warning safety	Decalque avertissement sécurité	1	105131
121	Decal read instructions	Decalque lire instructions	1	105130
122	Decal auger positioning	Décalque positionnement vis	1	107024

O/L = Obtain Locally

PARTS BREAKDOWN SUBFRAME

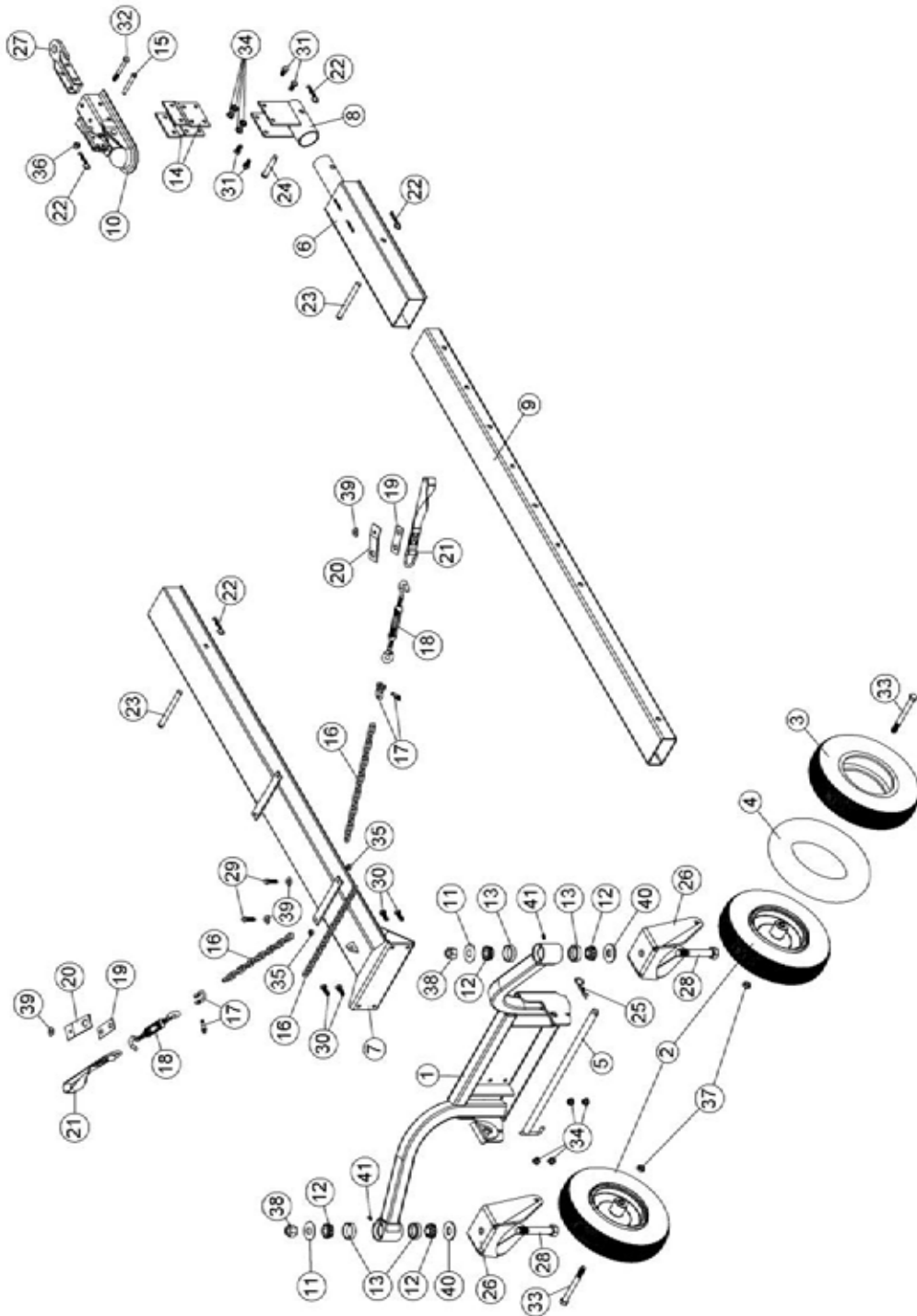

PARTS LIST SUBFRAME

1	Wheel support	Support de roue	1	106000
2	Wheel	Roue	2	105496
3	Tire 410/350-6	Pneu 410/350-6	1	105497
4	Inner tube 350-6	Chambre à air 350-6	1	105498
5	Pin	Goupille	1	105500
6	Rear bracket	Fixation arrière	1	104956
7	Subframe	Sous-châssis	1	104957
8	Hitch support	Support d'attache	1	104958
9	Adjustment tube	Tube d'ajustement	1	104959
10	Hitch	Attache	1	104639
11	Seal washer	Rondelle d'étanchéité	2	102289
12	Cone bearing	Roulement conique	4	102369
13	Cup for bearing	Cuvette	4	102370
14	Hitch support plate	Plaque de support d'attache	2	104641
15	Pin	Goupille	1	104642
16	Chain	Chaîne	3	104633
17	Shackle Ptd Z	Clevis Pqé Z	2	102343
18	Turnbuckle	Tendeur	2	104634
19	Bracket	Fixation	2	104632
20	Bracket	Fixation	2	105194
21	Lift strap	Sangle de relevage	2	103613
22	Hair pin 3mm	Goupille à ressort 3mm	4	102617
23	Pin	Goupille	2	104961
24	Pin	Goupille	1	104999
25	Hair pin 4mm	Goupille à ressort 4mm	1	102054
26	Wheel fork	Fourche de roue	2	105499
27	Hitch Ball Support	Support de boule d'attache	1	106214
28	Rod	Tige	2	106272
29	Hex. bolt 5/16" n.c. x 1 1/4" GR5	Boulon hex. 5/16" n.c. x 1 1/4" GR5	2	O/L
30	Hex. bolt 3/8" n.c. x 1" GR5	Boulon hex. 3/8" n.c. x 1" GR5	4	O/L
31	Hex. bolt 3/8" n.c. x 3/4" GR5	Boulon hex. 3/8" n.c. x 3/4" GR5	4	O/L
32	Hex. bolt 3/8" n.c. x 3" GR5	Boulon hex. 3/8" n.c. x 3" GR5	1	O/L
33	Hex. bolt 1/2" n.c. x 5" GR5	Boulon hex. 1/2" n.c. x 5" GR5	2	O/L
34	Flange nut 3/8" n.c.	Écrou à bride 3/8" n.c.	8	O/L
35	Nylon Insert lock Nut 5/16" n.c.	Écrou à garniture de nylon 5/16" n.c.	2	O/L
36	Nylon Insert lock Nut 3/8" n.c.	Écrou à garniture de nylon 3/8" n.c.	1	O/L
37	Nylon insert lock nut 1/2" n.c. (thin)	Écrou à garniture de nylon 1/2" n.c. (mince)	2	O/L
38	Nylon Insert lock Nut 3/4" n.c.	Écrou à garniture de nylon 3/4" n.c.	2	O/L
39	Flat washer 3/8" hole	Rondelle plate 3/8" trou	4	O/L
40	Flat washer 13/16" hole	Rondelle plate 13/16" trou	2	O/L
41	Grease fitting 1/4" n.f.	Graisseur 1/4" n.f.	2	O/L

O/L = Obtain Locally

PARTS BREAKDOWN

VANTAGE SNOWBLOWER WITH 24HP HONDA MOTOR

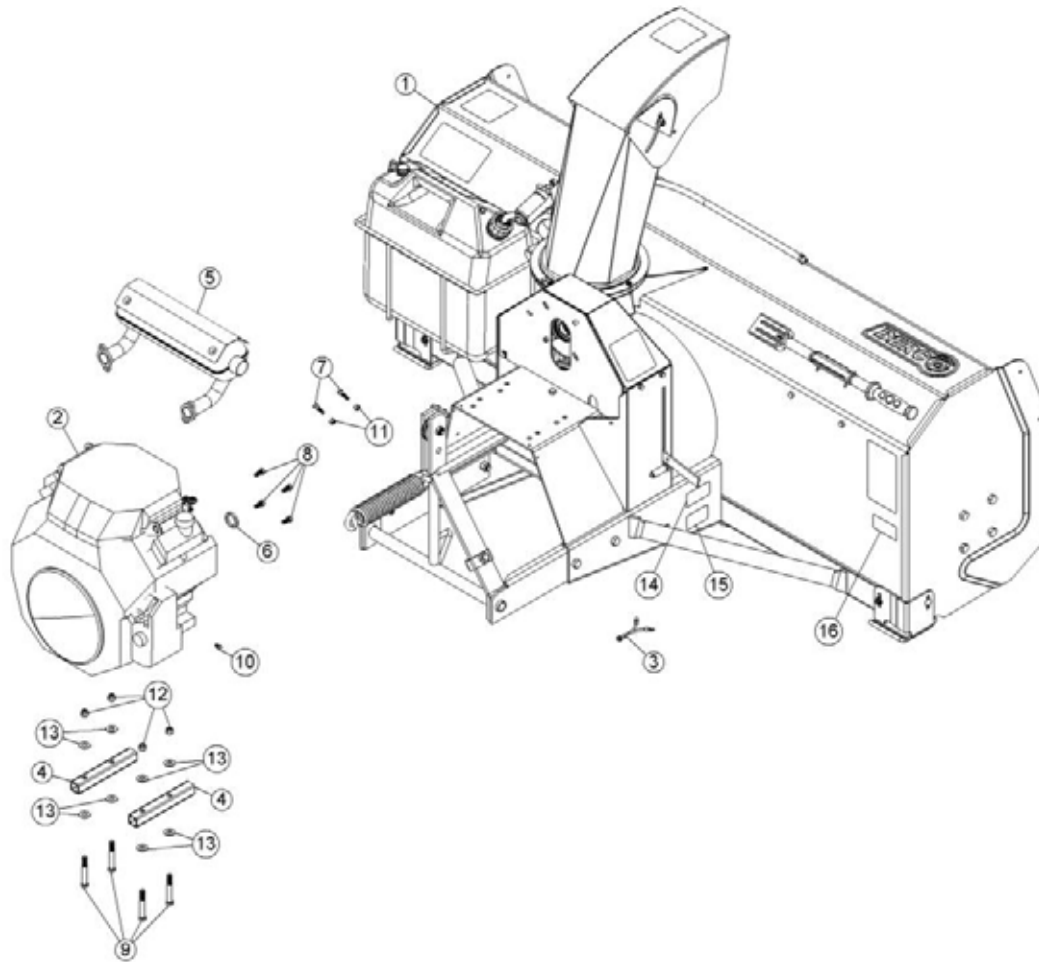

Ref. Réf.	English description	Description française	Qty. Qté.	Part # Pièce #
1	Snowblower	Souffleuse à neige	1	700512(513)-4-SM
2	Honda engine 24 hp with key	Moteur Honda 24 CV avec clé	1	105520
3	Stop emergency wire	Fil d'arrêt d'urgence	1	105597
4	Shim	Cale	2	105519
5	Honda muffler	Silencieux Honda	1	105448
6	Clutch spacer	Espaceur d'embrayage	1	106269
7	Hex. bolt 1/4" n.c. x 1" GR5	Boulon hex. 1/4" n.c. x 1" GR5	2	O/L
8	Hex. bolt 5/16" n.f. x 3/4" GR5	Boulon hex. 5/16" n.f. x 3/4" GR5	4	O/L
9	Hex. bolt 3/8" n.c. x 3" GR5	Boulon hex. 3/8" n.c. x 3" GR5	4	O/L
10	Hex. bolt M6 x 1.00 x 12 GR8.8	Boulon hex. M6 x 1.00 x 12 GR8.8	1	O/L
11	Nylon Insert lock Nut 1/4" n.c.	Écrou à garniture de nylon 1/4" n.c.	2	O/L
12	Nylon Insert lock Nut 3/8" n.c.	Écrou à garniture de nylon 3/8" n.c.	4	O/L
13	Flat washer 7/16" hole	Rondelle plate 7/16" trou	8	O/L
14	Serial number	Numéro de série	1	REF
15	Made in Canada decal	Décalque Fabriqué au Canada	1	REF
16	Specifications decal	Décalque spécifications	1	REF

O/L = Obtain Locally

PARTS BREAKDOWN

VANTAGE SNOWBLOWER EPA WITH 24HP HONDA MOTOR

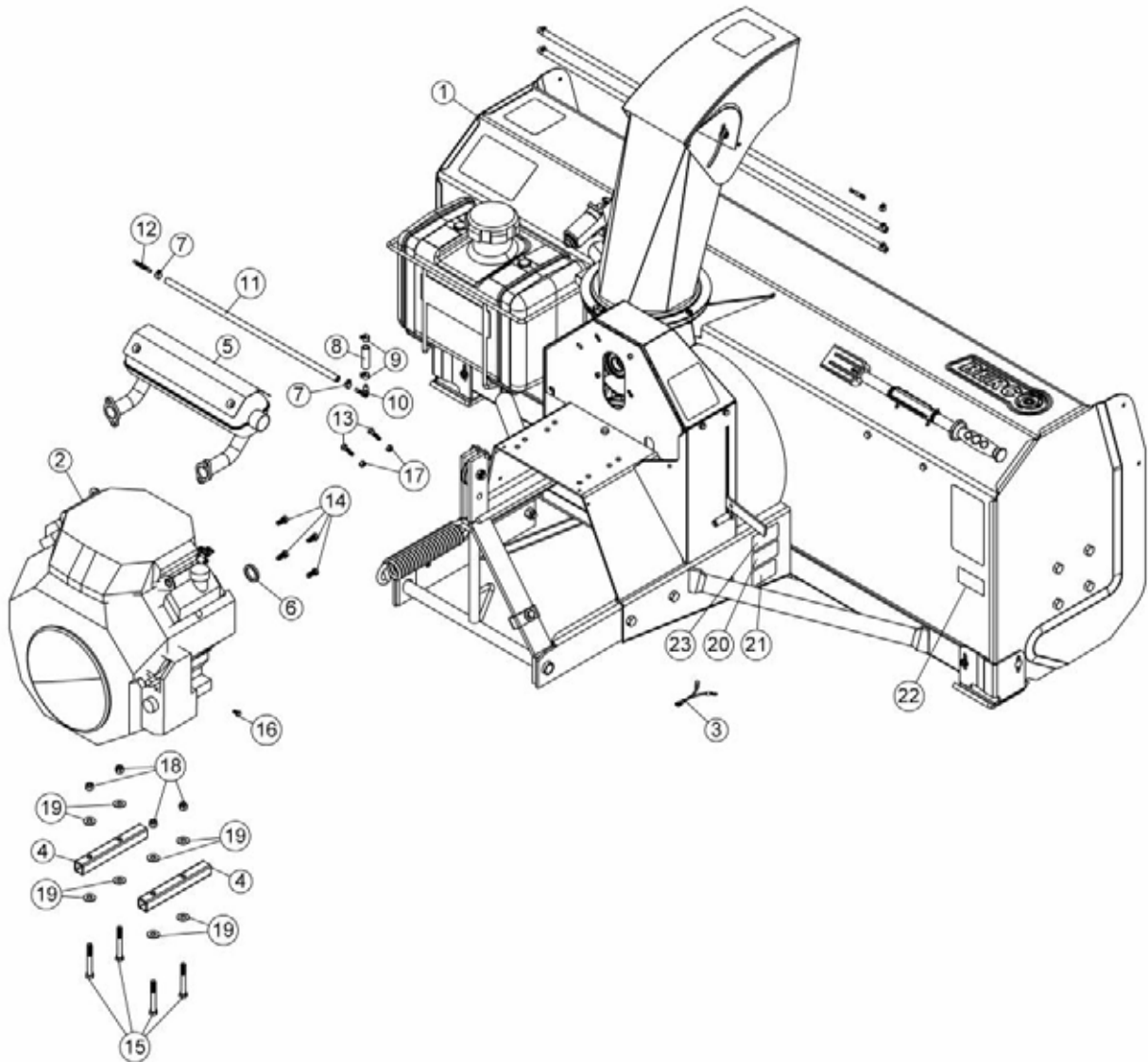

PARTS LIST

VANTAGE SNOWBLOWER EPA WITH 24HP HONDA MOTOR

Ref. Réf.	English description	Description française	Qty. Qté.	Part # Pièce #
1	Snowblower	Souffleuse à neige	1	700512 (513)-4- SM-EPA
2	Honda engine 24 hp with key	Moteur Honda 24 CV avec clé	1	105520
3	Stop emergency wire	Fil d'arrêt d'urgence	1	105597
4	Shim	Cale	2	105519
5	Honda muffler	Silencieux Honda	1	105448
6	Clutch spacer	Espaceur d'embrayage	1	106269
7	Spring action hose clamp for 1/2" hose	Collier de serrage à ressort pour tuyau 1/2"	2	107269
8	Fuel hose EPA 3/8"	Tuyau à essence EPA 3/8"	1	107326
9	Spring action hose clamp for 5/8" hose	Collier de serrage à ressort pour tuyau 5/8"	2	107327
10	Barb elbow adapter 3/8" x 1/4"	Adaptateur coudé à barbillon 3/8" x 1/4"	1	107328
11	Fuel hose EPA 1/4"	Tuyau à essence EPA 1/4"	1	107329
12	Barb adapter 1/4" x 1/4"	Adaptateur à barbillon 1/4" x 1/4"	1	107330
13	Hex. bolt 1/4" n.c. x 1" GR5	Boulon hex. 1/4" n.c. x 1" GR5	2	O/L
14	Hex. bolt 5/16" n.f. x 3/4" GR5	Boulon hex. 5/16" n.f. x 3/4" GR5	4	O/L
15	Hex. bolt 3/8" n.c. x 3" GR5	Boulon hex. 3/8" n.c. x 3" GR5	4	O/L
16	Hex. bolt M6 x 1.00 x 12 GR8.8	Boulon hex. M6 x 1.00 x 12 GR8.8	1	O/L
17	Nylon Insert lock Nut 1/4" n.c.	Écrou à garniture de nylon 1/4" n.c.	2	O/L
18	Nylon Insert lock Nut 3/8" n.c.	Écrou à garniture de nylon 3/8" n.c.	4	O/L
19	Flat washer 7/16" hole	Rondelle plate 7/16" trou	8	O/L
20	Serial number	Numéro de série	1	REF.
21	Made in Canada decal	Décalque Fabriqué au Canada	1	REF.
22	Specifications decal	Décalque spécifications	1	REF.
23	EPA decal	Décalque EPA	1	REF.

O/L = Obtain Locally

PARTS BREAKDOWN

VANTAGE SNOWBLOWER WITH KOHLER 22.5 HP ENGINE

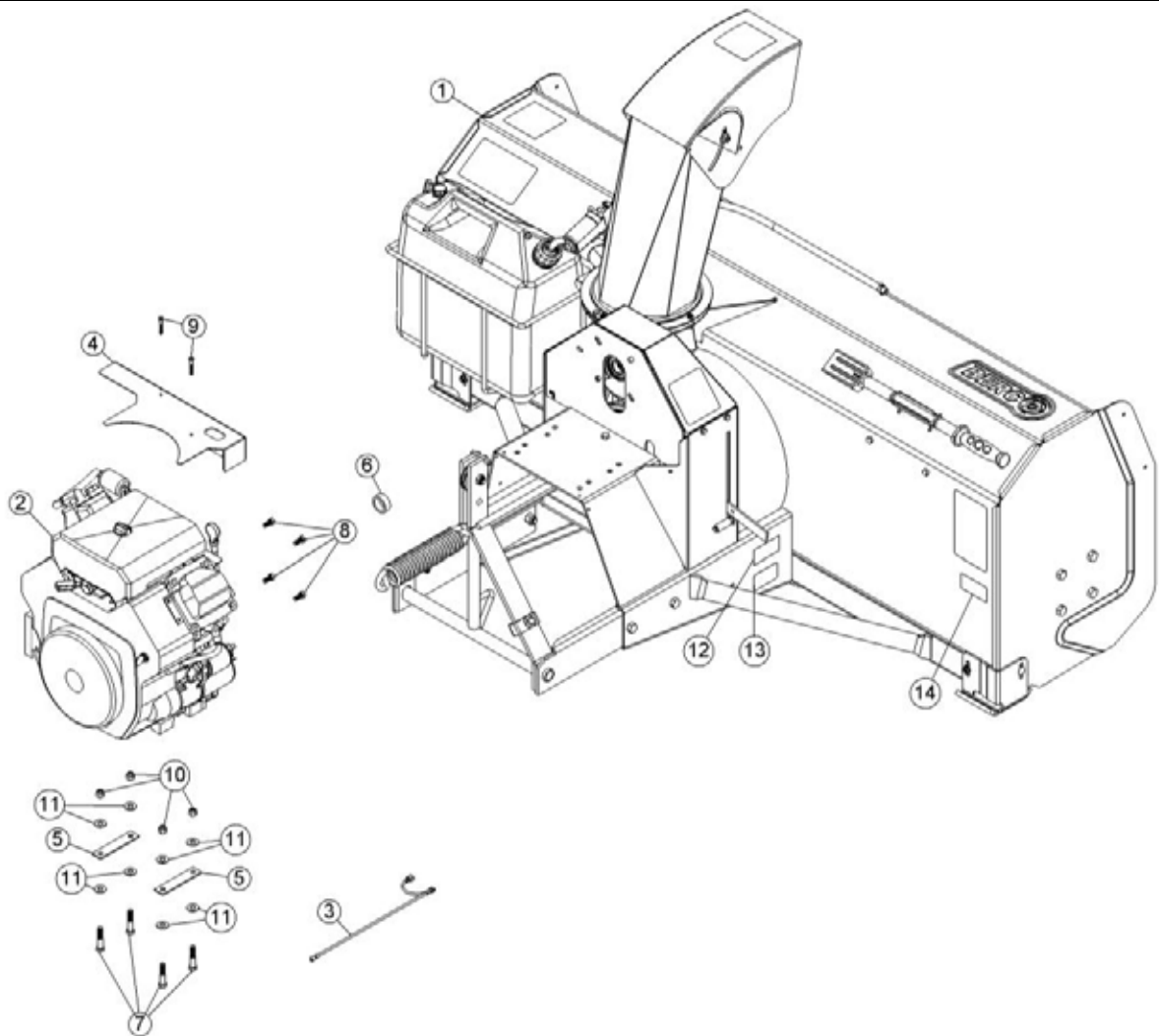

Ref. Réf.	English description	Description française	Qty. Qté.	Part # Pièce #
1	Snowblower	Souffleuse à neige	1	700512(513)-4-SM
2	Engine 22.5 Hp (Kohler)	Moteur 22.5 CV (Kohler)	1	107273
3	Wire assembly	Fil assemblé	1	105218
4	Heat shield	Pare-chaleur	1	104621
5	Shim	Cale	2	106266
6	Clutch spacer	Espaceur d'embrayage	1	106267
7	Hex. bolt 3/8" n.c. x 2" GR5	Boulon hex. 3/8" n.c. x 2" GR5	4	O/L
8	Hex. bolt 5/16" n.f. x 3/4" GR5	Boulon hex. 5/16" n.f. x 3/4" GR5	4	O/L
9	Machine screw Pan head no.10 x 32 x 1 1/2"	Vis mécanique tête pan no.10 x 32 x 1 1/2"	2	O/L
10	Nylon Insert lock Nut 3/8" n.c.	Écrou à garniture de nylon 3/8" n.c.	4	O/L
11	Flat washer 7/16" hole	Rondelle plate 7/16" trou	8	O/L
12	Serial number	Numéro de série	1	REF
13	Made in Canada decal	Décalque Fabriqué au Canada	1	REF
14	Specifications decal	Décalque spécifications	1	REF

PARTS BREAKDOWN

VANTAGE SNOWBLOWER EPA WITH KOHLER 22.5 HP ENGINE

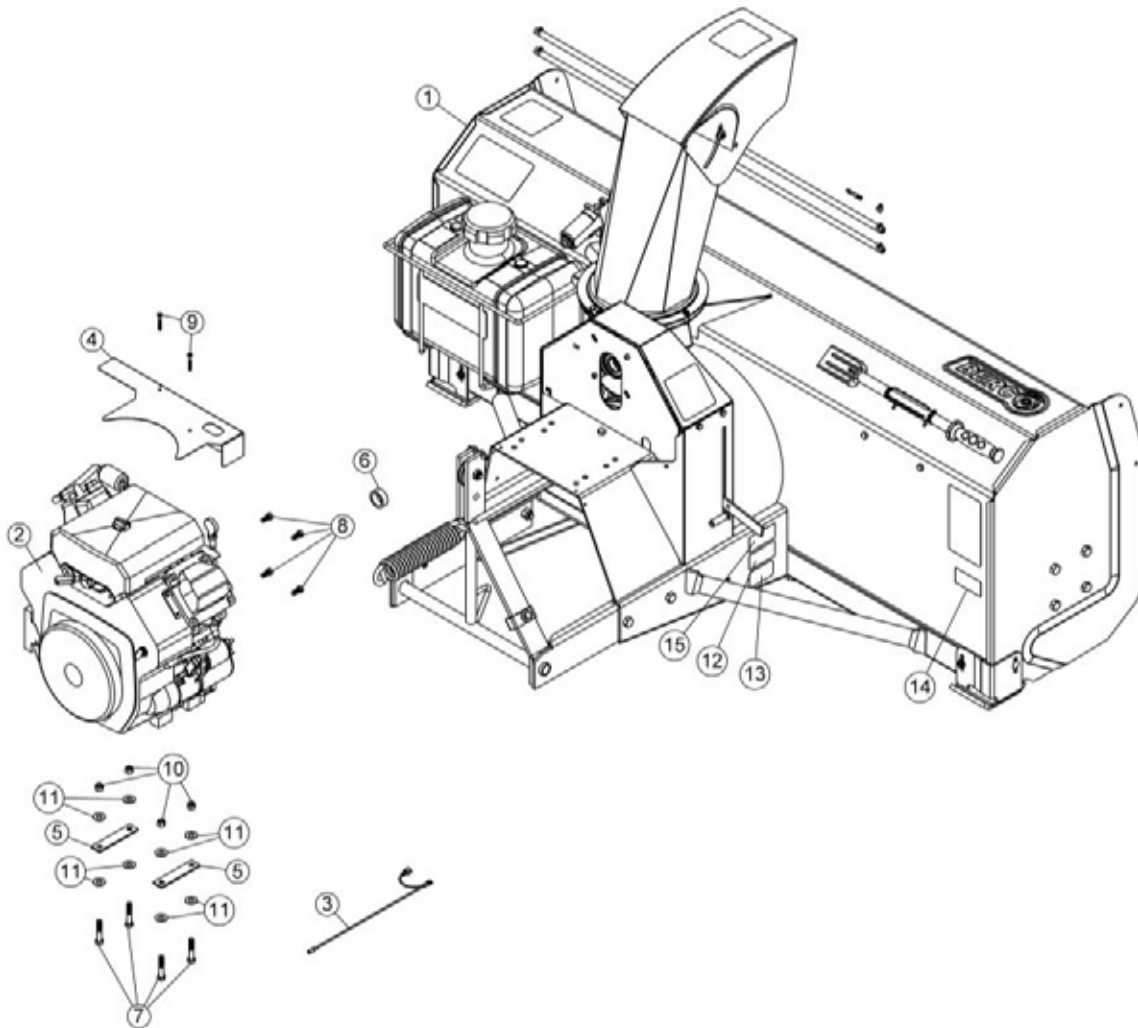

Ref. Réf.	English description	Description française	Qty. Qté.	Part # Pièce #
1	Snowblower 66"	Souffleuse à neige 66"	1	700512-4-SM-EPA
2	Engine 22.5 hp (Kohler) with control	Moteur 22.5 cv (Kohler) avec contrôle	1	107273
3	Wire assembly	Fil assemblé	1	105218
4	Heat shield	Pare-chaaleur	1	104621
5	Shim	Cale	2	106266
6	Clutch spacer	Espaceur d'embrayage	1	106267
7	Hex. bolt 3/8" n.c. x 2" GR5	Boulon hex. 3/8" n.c. x 2" GR5	4	O/L
8	Hex. bolt 5/16" n.f. x 3/4" GR5	Boulon hex. 5/16" n.f. x 3/4" GR5	4	O/L
9	Machine screw Pan head no.10 x 32 x 1 1/2"	Vis mécanique tête pan no.10 x 32 x 1 1/2"	2	O/L
10	Nylon Insert lock Nut 3/8" n.c.	Écrou à garniture de nylon 3/8" n.c.	4	O/L
11	Flat washer 7/16" hole	Rondelle plate 7/16" trou	8	O/L
12	Serial number	Numéro de série	1	REF
13	Made in Canada decal	Décalque Fabriqué au Canada	1	REF
14	Specifications decal	Décalque spécifications	1	REF
15	EPA decal	Décalque EPA	1	REF.

PARTS BREAKDOWN

VANTAGE SNOWBLOWER WITH KOHLER 25 HP ENGINE

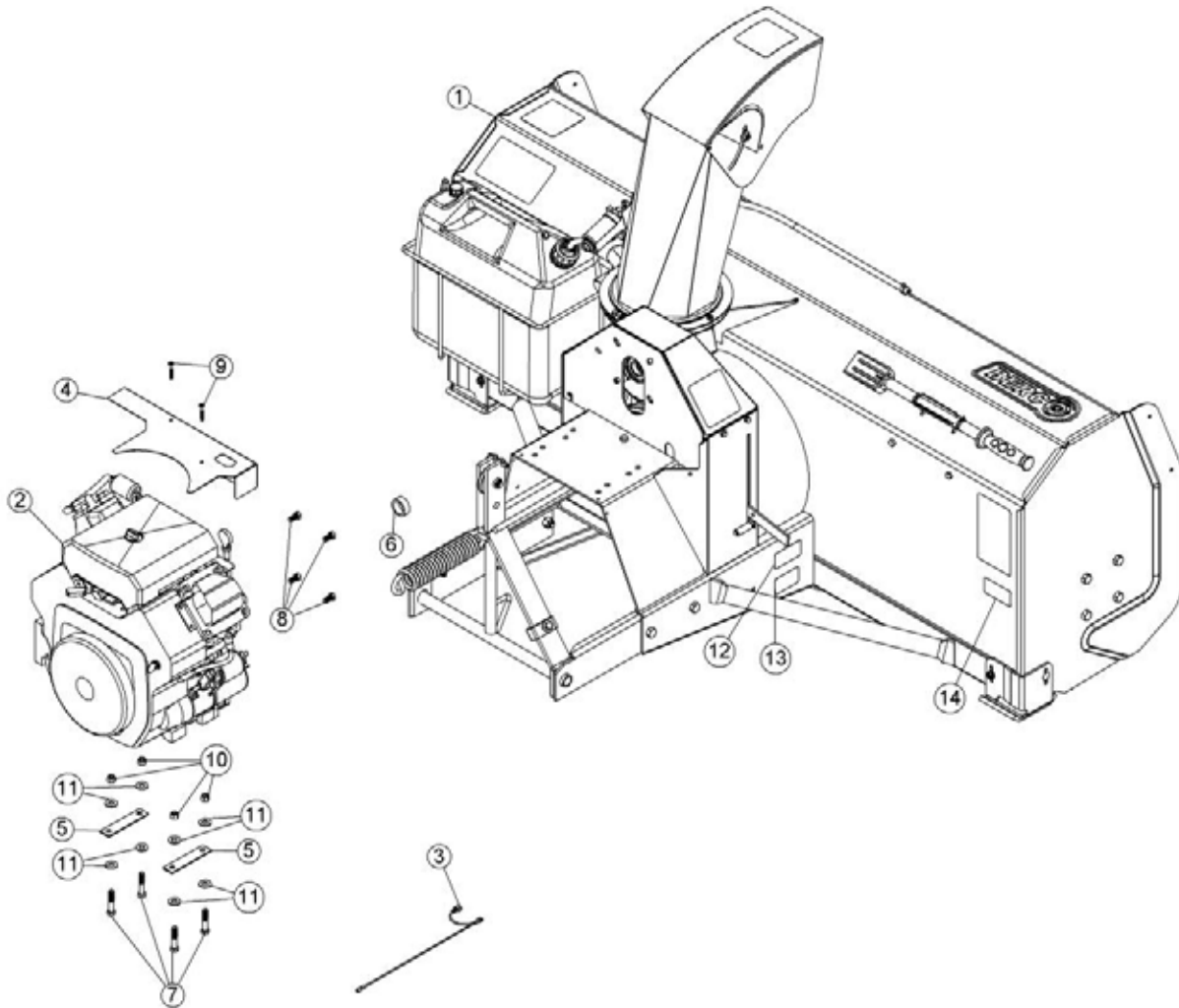

Ref. Réf.	English description	Description française	Qty. Qté.	Part # Pièce #
1	Snowblower	Souffleuse à neige	1	700512(513)-4-SM
2	Engine CH-25 (Kohler) with key	Moteur CH-25 (Kohler) avec clé	1	105521
3	Wire assembly	Fil assemblé	1	105218
4	Heat shield	Pare-chaieur	1	104621
5	Shim	Cale	2	106266
6	Clutch spacer	Espaceur d'embrayage	1	106267
7	Hex. bolt 3/8" n.c. x 2" GR5	Boulon hex. 3/8" n.c. x 2" GR5	4	O/L
8	Hex. bolt 3/8" n.c. x 3/4" GR5	Boulon hex. 3/8" n.c. x 3/4" GR5	4	O/L
9	Machine screw Pan head no.10 x 32 x 1 1/2"	Vis mécanique tête pan no.10 x 32 x 1 1/2"	2	O/L
10	Nylon Insert lock Nut 3/8" n.c.	Écrou à garniture de nylon 3/8" n.c.	4	O/L
11	Flat washer 7/16" hole	Rondelle plate 7/16" trou	8	O/L
12	Serial number	Numéro de série	1	REF
13	Made in Canada decal	Décalque Fabriqué au Canada	1	REF
14	Specifications decal	Décalque spécifications	1	REF

PARTS BREAKDOWN

VANTAGE SNOWBLOWER EPA WITH KOHLER 25 HP ENGINE

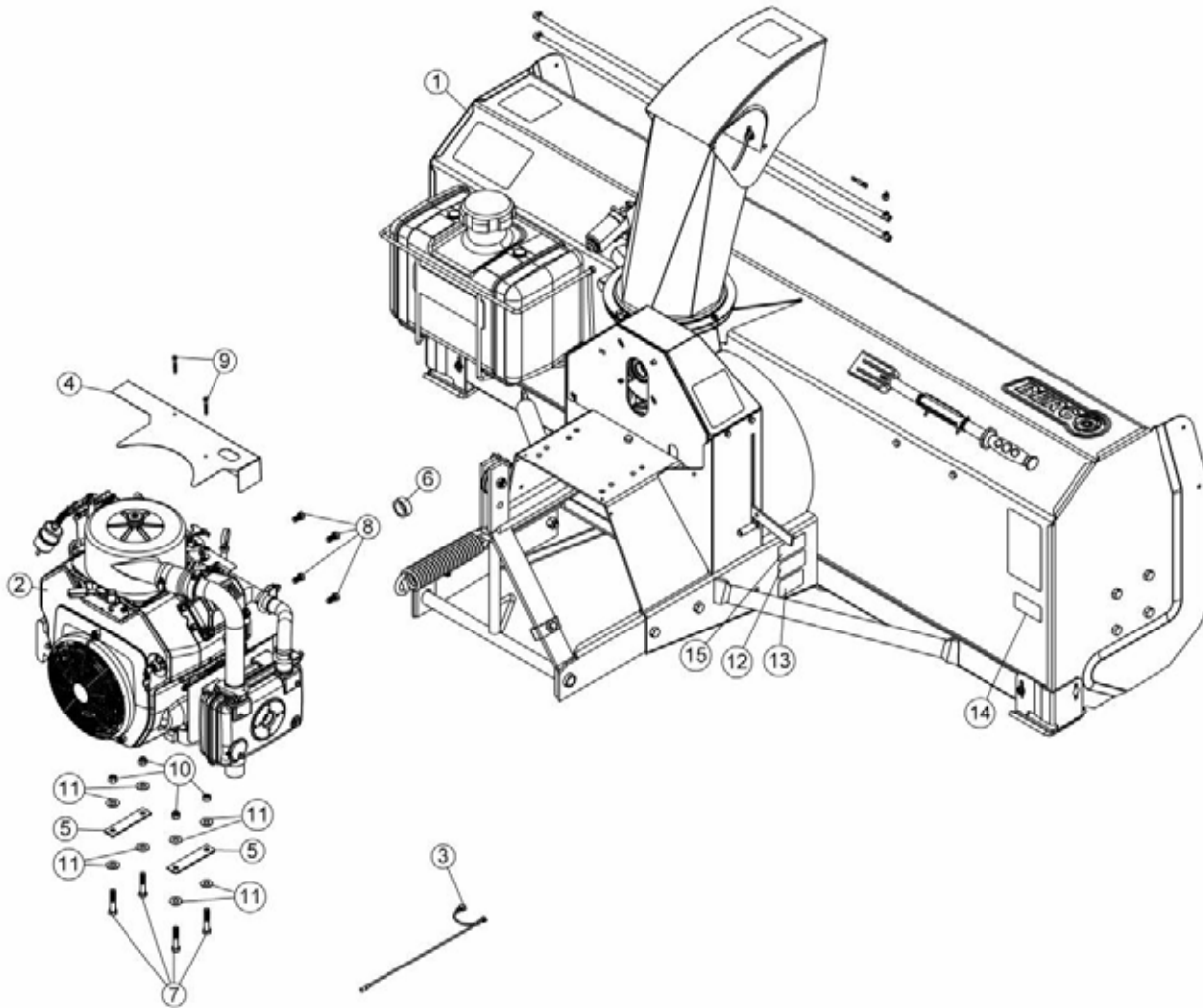

Ref. Réf.	English description	Description française	Qty. Qté.	Part # Pièce #
1	Snowblower	Souffleuse à neige	1	700512(513)-4-SM-EPA
2	Engine CH-25 (Kohler) with key	Moteur CH-25 (Kohler) avec clé	1	105521
3	Wire assembly	Fil assemblé	1	105218
4	Heat shield	Pare-chaleur	1	104621
5	Shim	Cale	2	106266
6	Clutch spacer	Espaceur d'embrayage	2	106267
7	Hex. bolt 3/8" n.c. x 2" GR5	Boulon hex. 3/8" n.c. x 2" GR5	4	O/L
8	Hex. bolt 3/8" n.c. x 3/4" GR5	Boulon hex. 3/8" n.c. x 3/4" GR5	4	O/L
9	Machine screw Pan head no.10 x 32 x 1 1/2"	Vis mécanique tête pan no.10 x 32 x 1 1/2"	2	O/L
10	Nylon Insert lock Nut 3/8" n.c.	Écrou à garniture de nylon 3/8" n.c.	4	O/L
11	Flat washer 7/16" hole	Rondelle plate 7/16" trou	8	O/L
12	Serial number	Numéro de série	1	REF
13	Made in Canada decal	Décalque Fabriqué au Canada	1	REF
14	Specifications decal	Décalque spécifications	1	REF
15	EPA decal	Décalque EPA	1	REF.

PARTS BREAKDOWN EXPLOSIVE VIEW

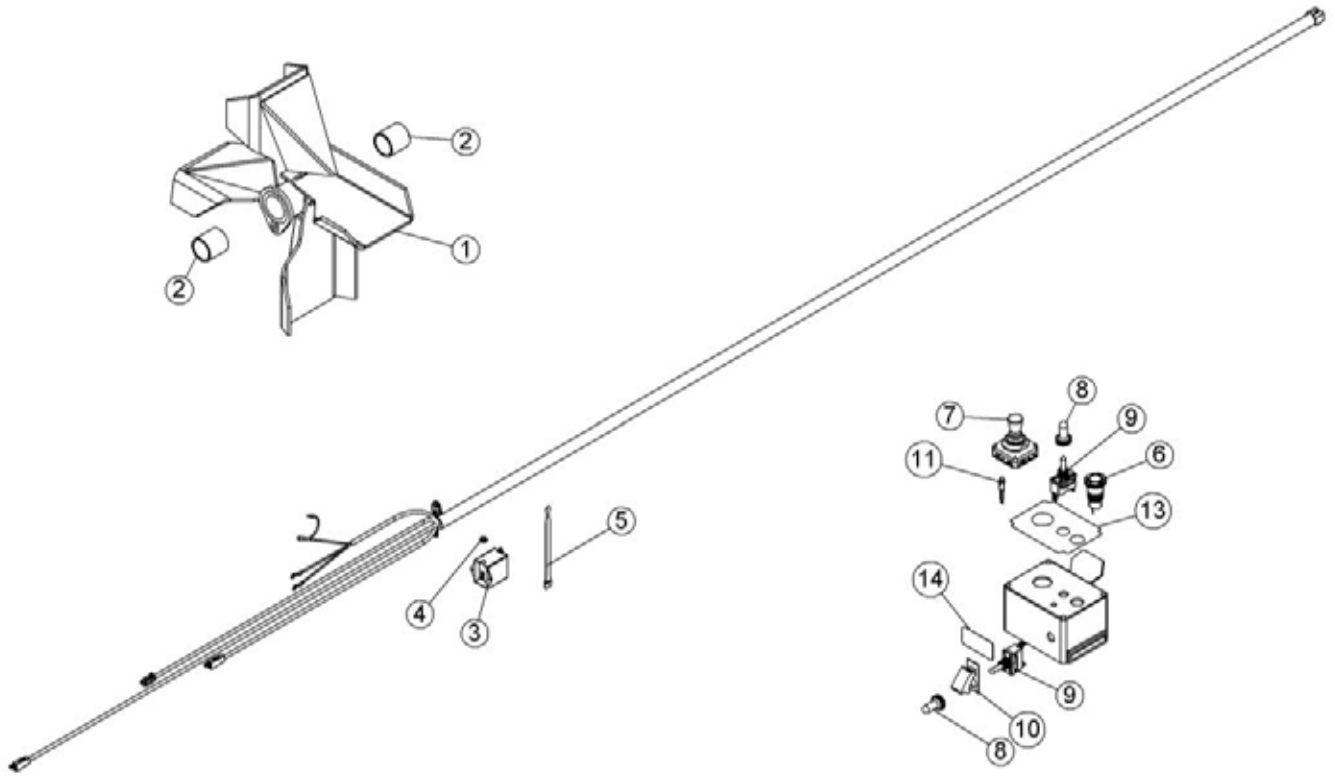

**PARTS BREAKDOWN
EXPLOSIVE VIEW**

**PARTS LIST
106700 - FAN WITH BUSHING - ÉVANTAIL AVEC COUSINET**

Ref. Réf.	English description	Description française	Qty. Qté.	Part # Pièce #
1	Fan	Éventail	1	106699
2	Oillite bushing	Coussinet imprégné d'huile	2	106382

**PARTS LIST
106558 - WIRE ASSEMBLY - FILS ASSEMBLÉS**

Ref. Réf.	English description	Description française	Qty. Qté.	Part # Pièce #
3	Relay socket	Socle pour relais	1	106559
4	Rubber grommet	Oeillet de caoutchouc	1	106563
5	Hook-it cable ties	Attache câble auto-grippante	1	104408

**PARTS LIST
106564 - CONTROL BOX ASSEMBLY - BOÎTE DE CONTRÔLE ASSEMBLÉE**

Ref. Réf.	English description	Description française	Qty. Qté.	Part # Pièce #
6	Emergency switch	Interrupteur d'urgence	1	105726
7	Joystick 4 positions	Levier de commande 4 positions	1	106160
8	Rubber boot	Capuchon de caoutchouc	2	106129
9	Switch	Commutateur	2	106182
10	Switch Guard	Garde du Commutateur	1	106177
11	Indicator light	Voyant lumineux	1	106561
12	Control box	Boitier de contrôle	1	106560a
13	Control box decal	Décalque de la boîte de contrôle	1	106121
14	Clutch decal	Décalque d'embrayage	1	106281

TORQUE SPECIFICATION TABLE

GENERAL TORQUE SPECIFICATION TABLE USE THE FOLLOWING TORQUES WHEN SPECIAL TORQUES ARE NOT GIVEN

NOTE: These values apply to fasteners as received from supplier, dry or when lubricated with normal oil. They do not apply if special graphited or moly disulphide greases or other extreme pressure lubricants are used. This applies to both UNF and UNC threads.

* Thick nuts must be used with grade 8 bolts

SEE Grade No.		2				5				8 *			
BOLT HEAD IDENTIFICATION MARKS AS PER GRADE NOTE MANUFACTURING MARKS WILL VARY		TORQUE				TORQUE				TORQUE			
BOLT SIZE		FOOT POUNDS		NEW TON-METERS		FOOT POUNDS		NEW TON-METERS		FOOT POUNDS		NEW TON-METERS	
Inches	Millimetre	Min.	Max.	Min.	Max.	Min.	Max.	Min.	Max.	Min.	Max.	Min.	Max.
1/4"	6.35	5	6	6.8	8.13	9	11	12.2	14.9	12	15	16.3	30.3
5/16"	7.94	10	12	13.6	16.3	17	20.5	23.1	27.8	24	29	32.5	39.3
3/8"	9.53	20	23	27.1	31.2	35	42	47.5	57	45	54	61	73.2
7/16"	11.11	30	35	40.7	47.4	54	64	73.2	86.8	70	84	94.9	113.9
1/2"	12.7	45	52	61	70.5	80	96	108.5	130.2	110	132	149.2	179
9/16"	14.29	65	75	88.1	101.6	110	132	149.2	179	160	192	217	260.4
5/8"	15.88	95	105	128.7	142.3	150	180	203.4	244.1	220	264	298.3	358
3/4"	19.05	150	185	203.3	250.7	270	324	366.1	439.3	380	456	515.3	618.3
7/8"	22.23	160	200	216.8	271	400	480	542.4	650.9	600	720	813.6	976.3
1"	25.4	250	300	338.8	406.5	580	696	786.5	943.8	900	1080	1220.4	1464.5

METRIC BOLT TORQUE SPECIFICATIONS							
		COARSE THREAD			FINE THREAD		
Size Screw	Grade No.	Pitch (mm)	Foot Pounds	Newton-Meters	Pitch (mm)	Foot Pounds	Newton-Meters
M6	4T	1.00	3.6 - 5.8	4.9 - 7.9	-	-	-
	7T		5.8 - 9.4	7.9 - 12.7		-	-
	8T		7.2 - 10	9.8 - 13.6		-	-
M8	4T	1.25	7.2 - 14	9.8 - 19	1.00	12 - 17	16.3 - 23
	7T		17 - 22	23 - 29.8		19 - 27	25.7 - 36.6
	8T		20 - 26	27.1 - 35.2		22 - 31	29.8 - 42
M10	4T	1.50	20 - 25	27.1 - 33.9	1.25	20 - 29	27.1 - 39.3
	7T		34 - 40	46.1 - 54.2		35 - 47	47.4 - 63.7
	8T		38 - 46	51.5 - 62.3		40 - 52	54.2 - 70.5
M12	4T	1.75	28 - 34	37.9 - 46.1	1.25	31 - 41	42 - 55.6
	7T		51 - 59	69.1 - 79.9		56 - 68	75.9 - 92.1
	8T		57 - 66	77.2 - 89.4		62 - 75	84 - 101.6
M14	4T	2.00	49 - 56	66.4 - 75.9	1.50	52 - 64	70.5 - 86.7
	7T		81 - 93	109.8 - 126		90 - 106	122 - 143.6
	8T		96 - 109	130.1 - 147.7		107 - 124	145 - 168
M16	4T	2.00	67 - 77	90.8 - 104.3	1.50	69 - 83	93.5 - 112.5
	7T		116 - 130	157.2 - 176.2		120 - 138	162.6 - 187
	8T		129 - 145	174.8 - 196.5		140 - 158	189.7 - 214.1
M18	4T	2.00	88 - 100	119.2 - 136	1.50	100 - 117	136 - 158.5
	7T		150 - 168	203.3 - 227.6		177 - 199	239.8 - 269.6
	8T		175 - 194	237.1 - 262.9		202 - 231	273.7 - 313
M20	4T	2.50	108 - 130	146.3 - 176.2	1.50	132 - 150	178.9 - 203.3
	7T		186 - 205	252 - 277.8		206 - 242	279.1 - 327.9
	8T		213 - 249	288.6 - 337.4		246 - 289	333.3 - 391.6

OPTIONS & ACCESSORIES

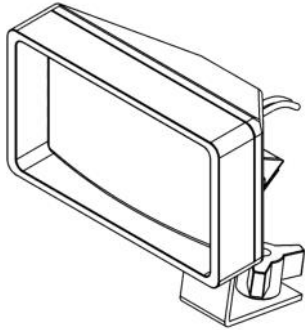

**#700456
LIGHT KIT**
Better visibility for night time use



**#700535
SNOW DRIFT CUTTER**
Slices through high snow drifts to facilitate and increase snow intake. Package of 2.

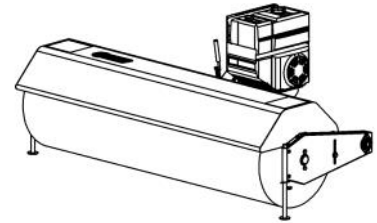

**#700516
66" ROTARY BROOM**
For UV

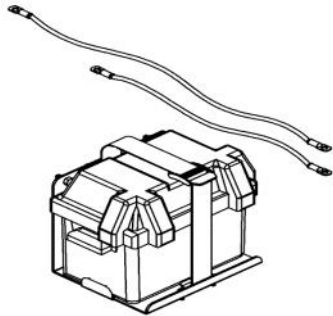

**#700524
SUPPORT FOR BATTERY
(BATTERY NOT INCLUDED)**
For ATV or UV

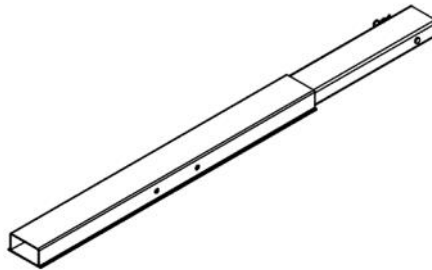

SUBFRAME EXTENSION
#700485
For bigger vehicle



***WHEN PERFORMANCE
& DEPENDABILITY
ARE NON NEGOTIABLE!***

**Bercomac Limitée
92, Fortin North, Adstock, Quebec, Canada, G0N 1S0**

WWW.BERCOMAC.COM

PRINTED IN CANADA

(ORIGINAL NOTICE)