



OWNER'S MANUAL
Model Number

700533 66" Snowblower



BERCO
66" Snowblower
For
ZERO TURN MOWERS

- * ASSEMBLY
- * OPERATION

- * REPAIR PARTS
- * MAINTENANCE

CAUTION:

**READ & FOLLOW ALL SAFETY RULES & INSTRUCTIONS BEFORE
OPERATING YOUR EQUIPMENT**



LIMITED WARRANTY

Conditions and Products Covered:

BERCOMAC guarantees any part of the product or accessory manufactured by BERCOMAC and found in the reasonable judgment of BERCOMAC to be defective in material and or workmanship will be repaired or replaced by an authorized dealer without charge up to our maximum labor rates and pre-established times. For replacement parts only standard ground freight services are covered. This warranty extends to the original retail purchaser only and is not transferable to any subsequent purchasers.

Warranty Period

(from date of the original retail purchase)

- Semi-commercial use: 1 year
- Commercial, professional or rental use: 90 days

Exceptions Noted Below; the following items are guaranteed by the original manufacturer and have their own warranty, conditions and limited time:

- Tire Chains: 90 days
- Engines: Will vary as per the manufacturer
Please refer to the engine manufacturer's warranty statement included with the unit. BERCOMAC is not authorized to handle warranty adjustments on engines.

Items and Conditions NOT Covered:

This warranty does not cover the following:

- Pick-up or delivery charges or in-home services fees.
- Any damage or deterioration of the unit, parts and or finish of these due to normal use, wear and tear, or exposure.
- Cost of regular use or maintenance service or parts, such as gas, oil, lubricants, tune-up parts, and adjustments.
- Any part or accessory which has been altered, modified, misused, neglected, accidentally damaged or not properly installed, maintained, stored or repaired not in accordance with the instructions in the owner's manual.
- Repair due to normal wear and or any wear items such as shear pins, bolts, belts, etc.
- Expedited freight fee services for replacement parts.
- Shear bolts and shear pins are to be considered as a preventive measure not as an assured protection, any damages resulting from the lack of shear bolts breakage are not covered.

NOTE: All warranty work must be performed by an authorized dealer using original (manufacturer) replacement parts.

NOTE: Bercomac reserves the right to change or improve the design of any part or accessory without assuming any obligation to modify any product previously manufactured.

Instructions for Obtaining Warranty Services:

Contact dealer where equipment was purchased or any other BERCOMAC service dealer to arrange service at their dealership. To locate a dealer convenient to you, access our website at www.bercomac.com. Don't forget to bring the product and your proof of purchase (sales receipt) to the BERCOMAC dealer.

Owner's Responsibilities:

BERCOMAC's defective equipment or part must be returned to an authorized dealer within the warranty period for repairs. In the event that defective merchandise must be returned to manufacturer for repairs, freight fees are prepaid and a written authorization from BERCOMAC must be obtained by dealer prior to the shipment. This warranty extends only to equipment operated under normal conditions. To validate a warranty claim, it is the user's responsibility to maintain and service the unit as specified in the owner's manual or to have the unit serviced at their dealer at their expense.

General Conditions:

The sole liability of BERCOMAC with respect to this warranty shall be strictly and exclusively repair and replacement as mentioned herein. BERCOMAC shall not have any liability for any other costs, loss or damage, including but not limited to, any incidental or consequential loss or damage.

In particular, without being limited to, BERCOMAC shall have no liability or responsibility for:

- Travel time, overtime, after hours time or other extraordinary repair charges or relating to repairs and or replacements outside of normal business hours.
- Rental of like or similar replacement equipment during the period of any, repair or replacement work.
- Any communicating or travel charges.
- Loss or damage to person or property other than that covered by the terms of this warranty.
- Any claims for lost revenue, lost profit or any similar costs as a result of damage or repair.
- Attorney's fees.

BERCOMAC's responsibility in respect to claims is limited to making the required repairs or replacement without charge up to our maximum labor rates and pre-established times and no claim of breach of warranty shall be cause for cancellation or rescission of the contract of sale of any product or accessory.

This warranty gives you specific legal rights. You may also have other rights, which vary from state to state.

TABLE OF CONTENTS

	PAGE
INTRODUCTION	2
SAFETY PRECAUTIONS	3
SAFETY DECALS	5
ASSEMBLY	
Tools Required	6
Step 1: Snowblower Preparation	6
Step 2: Snowblower Installation	8
Step 3: Control Box Installation	9
Step 4: Skid Shoe Adjustment and Installation of the Spring	11
OPERATION	
Operating the Snowblower	12
Electrical Controls	12
Removing Snow	12
Clearing a Clogged Chute	12
MAINTENANCE	
Adjustments	13
Lubrication	13
Cutting Edge Maintenance	13
Clearing a Clogged Discharge Chute	13
Augers and Fan Shear Bolt Replacement	13
Belt installation, Adjustment and Replacement	14
DISMOUNTING & STORAGE	15
TROUBLESHOOTING	16
TORQUE SPECIFICATION TABLE	19
PARTS BREAKDOWN AND PARTS LIST	
66" Snowblower	20
OPTIONS & ATTACHMENTS	25

INTRODUCTION

TO THE PURCHASER

This new accessory was carefully designed to give years of dependable service. This manual has been provided to assist in the safe operation and servicing of your attachment.

NOTE: All photographs and illustrations in the manual may not necessarily depict the actual models or attachment, but are intended for reference only and are based on the latest product information available at the time of publication.

Familiarize yourself fully with the safety recommendations and operating procedures before putting the machine to use. Carefully read, understand and follow these recommendations and insist that they be followed by those who will use this attachment.



THIS SAFETY ALERT SYMBOL IDENTIFIES AN IMPORTANT SAFETY MESSAGE IN THIS MANUAL THAT HELPS YOU AND OTHERS AVOID PERSONAL INJURY OR EVEN DEATH. DANGER, WARNING, AND CAUTION ARE SIGNAL WORDS USED TO IDENTIFY THE LEVEL OF HAZARD. HOWEVER, REGARDLESS OF THE HAZARD, BE EXTREMELY CAREFUL.

DANGER: Signals an extreme hazard that will cause serious injury or death if recommended precautions are not followed.

WARNING: Signals a hazard that may cause serious injury or death if the recommended precautions are not followed.

CAUTION: Signals a hazard that may cause minor or moderate injury if the recommended precautions are not followed.

Record your attachment serial number and purchase date in the section reserved below (there is no serial number on the subframe). Your dealer requires this information to give you prompt, efficient service when ordering replacement parts. Use only genuine parts when replacements are required.

If warranty repairs are required please present this registration booklet and original sales invoice to your selling dealer for warranty service.

**This manual should be kept for future reference.
Please check if you have received all the parts for your kit with the list of the bag and the list of the box.**

SERIAL NUMBER : (IF APPLICABLE)	
MODEL NUMBER:	
PURCHASE DATE :	



SAFETY PRECAUTIONS



Careful operation is your best insurance against an accident. Read this section carefully before operating the vehicle and accessory. This accessory is capable of amputating hands and feet and throwing objects. Failure to observe the following safety instructions could result in serious injury. All operators, no matter how experienced they may be, should read this and other manuals related to the vehicle and accessory before operating. It is the owner's legal obligation to instruct all operators in safe operation of the accessory.

GLOSSARY:

In this manual, right and left sides are determined by sitting on the seat of the vehicle facing forward.

In this manual, "accessories" means attachments (snowblower, rotary broom, blade etc.) that you install on the vehicle (lawn tractors, A.T.V. s etc).

TRAINING:



This symbol, "Safety Alert Symbol", is used throughout this manual and on the accessory's safety labels to warn of the possibility of serious injury. Please take special care in reading and understanding the safety precautions before operating the vehicle and accessory.

1. Read this owner's manual carefully. Be thoroughly familiar with the controls and proper use of the vehicle and accessory. Know how to stop the unit and disengage the controls quickly.
2. Never allow children to operate the vehicle nor the accessory. Never allow adults to operate the vehicle nor the accessory without proper instructions.
3. No one should operate the vehicle nor the accessory while intoxicated or while taking medication that impairs the senses or reactions.
4. Keep the area of operation clear of all people, particularly small children and pets.

PREPARATION:

1. Thoroughly inspect the area where the accessory is to be used and remove door mats, all foreign objects and the like.
2. For motorized accessories, disengage all clutches and shift into neutral before starting engine.
3. Do not operate the accessory without wearing adequate winter outer garments. Avoid loose fitting clothing that can get caught in moving parts. Wear footwear that will improve footing on slippery surfaces.

4. Handle fuel with care, it is highly flammable.

- a) Use approved fuel container.
 - b) Never add fuel to a running engine or hot engine.
 - c) Fill fuel tank outdoors with extreme care. Never fill fuel tank indoors.
 - d) Never fill containers inside a vehicle, or on a truck or a trailer bed with a plastic liner. Always place containers on the ground, away from your vehicle, before filling.
 - e) When practical, remove gas-powered equipment from the truck or trailer and refuel it on the ground. If this is not possible, then refuel such equipment on a trailer with a portable container, rather than from a gasoline dispenser nozzle.
 - f) Keep the nozzle in contact with the rim of the fuel tank or container opening at all times, until refueling is complete. Do not use a nozzle lock-open device.
 - g) Replace fuel cap securely and wipe up spilled fuel.
 - h) If fuel is spilled on clothing, change clothing immediately.
5. Never attempt to make any adjustments while the engine (motor) is running (except when specifically recommended by manufacturer).
 6. Let the vehicle and accessory adjust to outdoor temperatures before using.
 7. Never use an accessory without proper guards, plates, or other safety protective devices in place
 8. Always make sure to wear the appropriate safety equipment required (glasses, muffs, mask...) for each type of product. See operation section.
 9. Always make sure of having safe traction on the vehicle by using the recommended accessories (chains, A.T.V. tracks, counterweights...). See operation section.
 10. **Never modify the accessory or any part without the written consent from the manufacturer.**



SAFETY PRECAUTIONS



OPERATION:

1. Do not put hands or feet near, under or inside rotating parts.
2. Exercise extreme caution when operating on or crossing gravel drives, walks or roads. Stay alert for hidden hazards or traffic. Do not carry passengers.
3. After striking a foreign object, stop the engine (motor), disconnect the wire from the spark plug(s) and keep wire away to prevent accidental starting. Thoroughly inspect the accessory for any damage and repair damage before restarting and using the accessory.
4. If the unit should start to vibrate abnormally, stop the engine (motor) and check immediately for the cause. Vibration is generally a warning of trouble.
5. Take all possible precautions when leaving the vehicle unattended. Disengage the power take-off, lower the attachment, place the transmission into neutral, set the parking brake, stop the engine and remove the contact key.
6. Do not run the engine indoors, except when starting the engine and for transporting in or out of the building. Do not operate or let motor run in a storage area without ventilation because gas contains carbon monoxide which is odorless, colorless and can cause death.
7. Never use the accessories across the face of slopes, go from top to bottom. Exercise extreme caution when using equipment on slopes. Do not attempt to clear a steep slope.
8. Never tolerate bystanders in the working zone. Never use an accessory in the direction of bystanders, it might throw gravel or debris that can hurt people or damage property.
9. Never operate the accessory at high transport speeds on slippery surfaces. Use care when backing up.
10. Do not carry passengers.
11. Disengage power to the accessory when it is transported or not in use.
12. Never operate the accessory without good visibility or light.

13. Keep the accessory away from heat sources or flames.

MAINTENANCE AND STORAGE

1. When cleaning, repairing or inspecting the vehicle and accessory, make certain that all moving parts have stopped. Disconnect wire from the spark plug(s) and keep wire away to prevent accidental starting.
2. Check all the bolts and components at frequent intervals to make sure that they are properly tightened.
3. Never store a motorized accessory with fuel in the fuel tank inside a building where ignition sources are present such as hot water and space heaters, clothes dryers, and the like. Allow the engine to cool before storing in any enclosure.
4. Always refer to the owner's manual when you store the accessory and vehicle for a prolonged or an unspecified length of time.
5. Maintain or replace safety and instruction labels, as necessary.
6. For winter accessories, (if applicable), let the engine run for a few minutes after clean snow in order to prevent the rotary parts from freezing.
7. Inspect the vehicle's and accessory's air filter every day. Clean it or replace it as necessary. Change the oil more often when working in dusty conditions. See the vehicle's and accessory's owner's manual.



**THIS SYMBOL MEANS
DANGER !
BECOME ALERT !
YOUR SAFETY IS INVOLVED !**



SAFETY DECALS



REPLACE IF DECALS ARE DAMAGED SEE PARTS BREAKDOWN FOR DECAL LOCATION

DECAL #105126



To avoid serious injury:
Keep hands, feet & clothing away from rotating auger while engine is running.

DECAL #105130

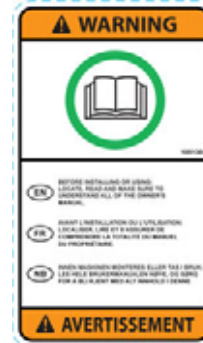

Before installing or using:
Locate, read and make sure to understand all of the owner's manual.

DECAL #105127



To avoid serious injury:
Keep hands out of this discharge chute while engine is running.

DECAL #105131

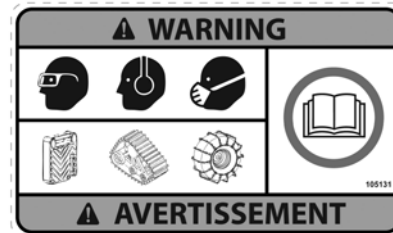

Refer to owner's manual about wearing safety glasses, ear muffs and mask.
Refer to owner's manual for use of counter weights, cat tracks and tire chains.

DECAL #105128



To avoid injury from drive belt:
Keep hands, feet & clothing away.
Do not attempt to install or remove drive belt without reading owner's manual.

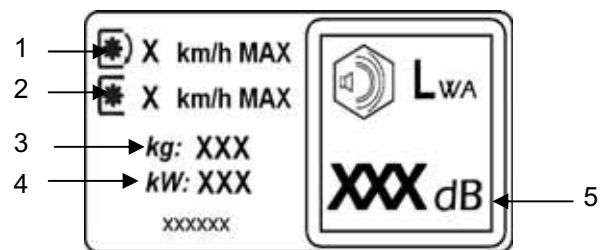

- 1-Do not drive faster than 3 KM/H when the snowblower is in operation.
- 2-Do not drive faster than 10 KM/H when the snowblower is in the raised position.
- 3-The head of the snowblower weighs 155kg.
- 4-The engine wattage is 17.2kW. (according to the engine of the vehicle).
- 5-The sound pressure level (107dBA) is measured at the engine (full charge at 3600 RPM) and depends on the engine that is installed. The value indicated is a reference only.

ASSEMBLY

IMPORTANT: TORQUE ALL BOLTS ACCORDING TO TORQUE SPECIFICATION TABLE (SEE TABLE OF CONTENTS) WHEN STATED: TIGHTEN FIRMLY. REFER TO PARTS BREAKDOWN SECTION FOR PART IDENTIFICATION.

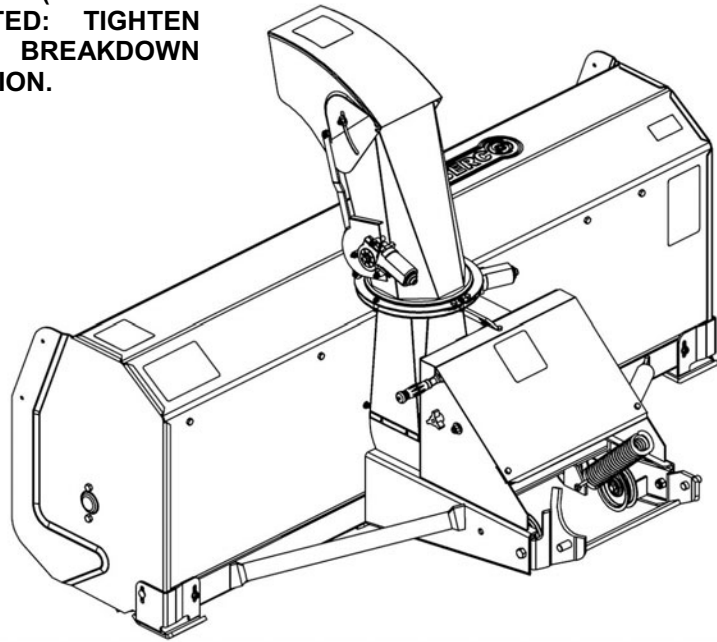

Overall view of snowblower

TOOLS REQUIRED:

- Wrench: 7/16"
- Socket: 7/16"
- Screwdriver No.2
- Pliers
- Allen Key 1/8"
- Hammer
- Pry Bar

STEP 1

SNOWBLOWER PREPARATION:

Refer to parts breakdown section for parts identification.

Install the nylon rotation ring (item 1).		
# Item	Description	Action
1	Rotation ring (nylon)	Install over the opening as shown and align the notches.

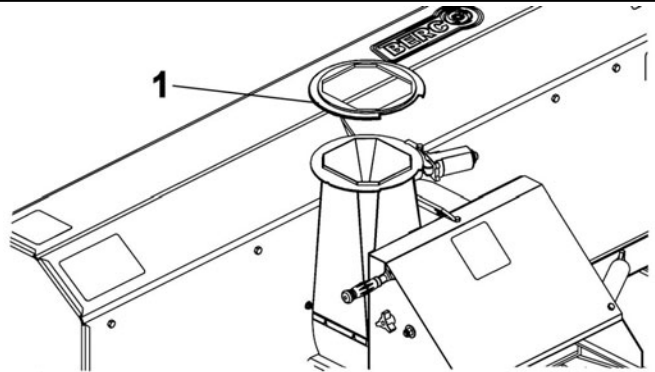

Install the nylon rotation ring

Install the rotation ring (item 1).		
# Item	Description	Action
1	Rotation ring	Install over the opening as shown.

NOTE: Place the rotation ring (item 1) approximately as shown in the drawing, the groves of the rotation ring on the teeth of the rotation motor.

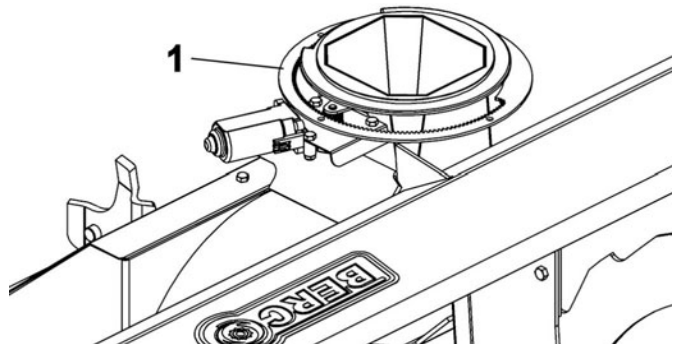

ASSEMBLY

Install the chute (item 1).

# Item	Description	Action
1	Chute	Place the chute on the nylon rotation ring. Turn the chute to make sure it turns freely. Place the chute at 45° angle as shown.
2	Hex bolt 1/4" n.c x 1" (qty 4)	Insert under the rotation ring (item 5) as shown.
3	Spacers (qty 4)	Install on the bolts between the rotation ring and the chute.
4	Nylon insert lock nuts 1/4" (qty 4)	Secure everything in place.

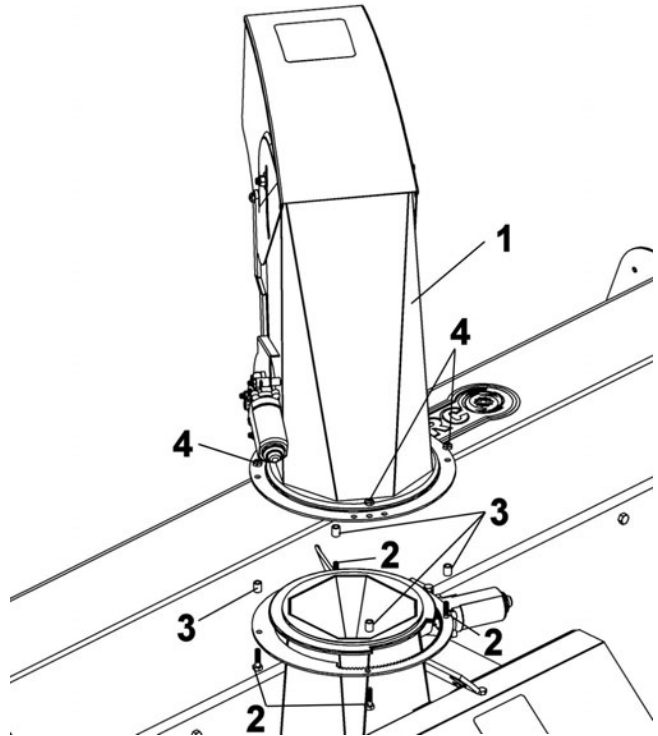

Install the chute

Install the retaining plate (item 2) under the chute .

# Item	Description	Action
1	Hex. bolt 1/4" n.c. x 1/2" (qty 2)	Insert as shown.
2	Retaining plate	Install as shown under the chute
3	Nylon insert lock nut 1/4" thin (qty 2)	Secure in place.

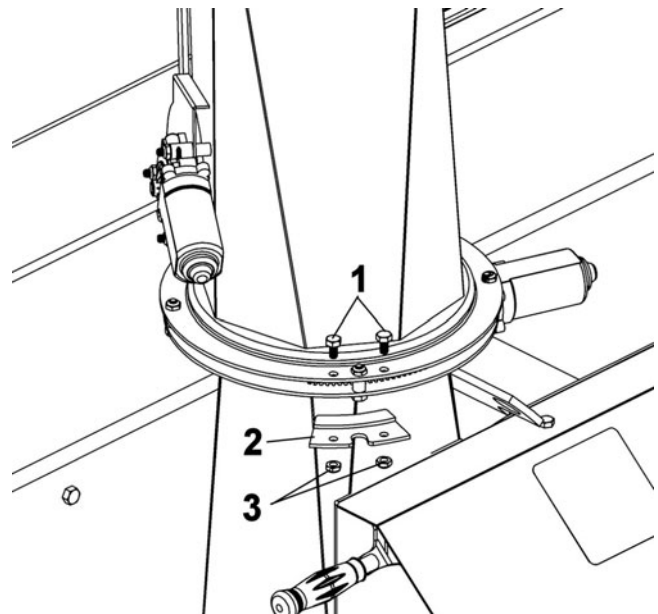

Install the retaining plate

INSTALLATION

STEP 2

SNOWBLOWER INSTALLATION:

You must install the subframe and drive mechanism before continuing to install the snowblower.



WARNING



TO PREVENT INJURIES:

Stop the motor.

Apply parking brake.

Remove the ignition key.

Disconnect the wire from the spark plug(s) and keep away from spark plug(s) to prevent accidental starting.

Attach the snowblower to the subframe as shown.

TIPS: Install a block under the snowblower. Align and drive the vehicle forward up to the snowblower to quick connect the snowblower to the subframe.

Make sure the snowblower is pushed in until locked into place by the lock (item 1).

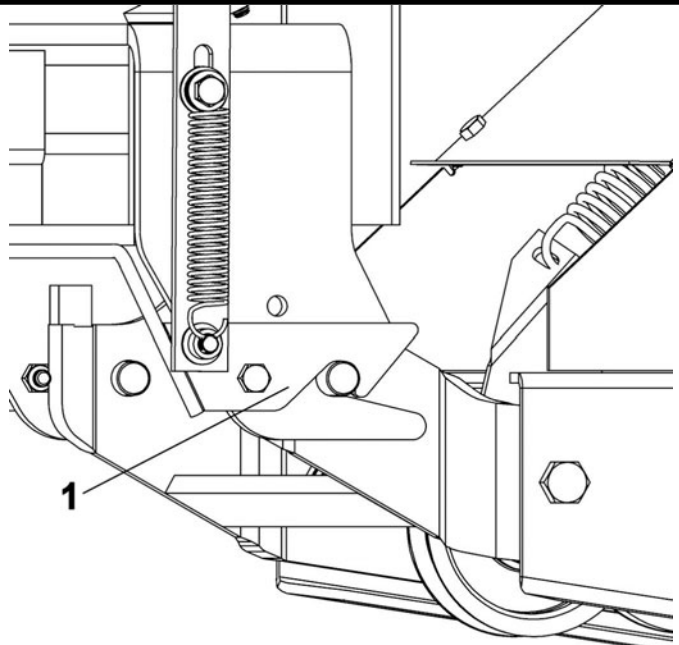

Insert the snowblower in the lock.

NOTE: See the belt installation instructions in the Maintenance section.



WARNING



Never use the snowblower without the belt guard.

After installing the belt, hook the pulley block (item 1) in the bracket as shown.

# Item	Description	Action
1	Pulley block	Hook into the bracket as shown.

NOTE: To thread the winch cable, you must remove the pulley from the pulley block.

2	End of the cable	Install over the hole on the subframe as shown.
3	Flat washer 3/8"	Install over the end of the cable.
4	Bolt 5/16" x 1"	Install in the flat washer and secure with a nylon insert locknut.

Familiarize yourself with the winch control and make sure the cable stays wrapped from the bottom of the drum of the winch. See picture of the winch in the subframe's owner manual.

Lift and lower the snowblower using the switch.

When lowering the accessory, release the switch of the winch control as soon as the accessory touches the ground.



WARNING



The belt tension arm & needs to be held firmly while displacing to prevent injury.

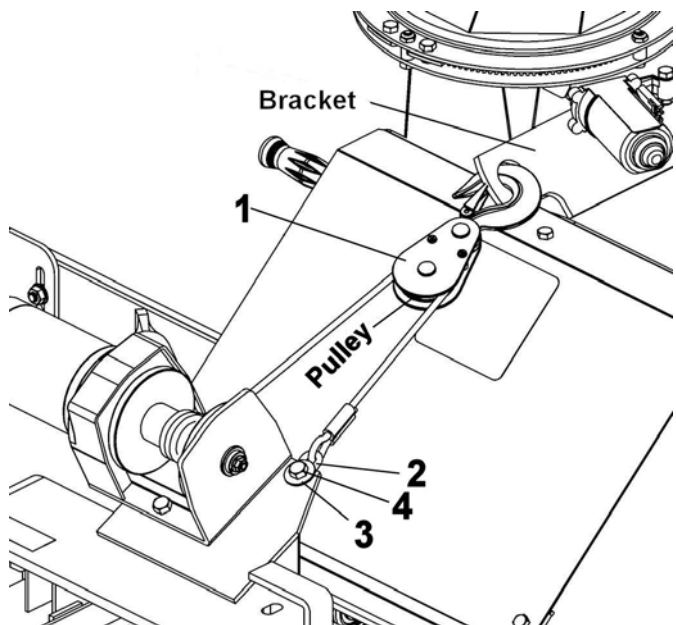

Install the pulley block

ASSEMBLY

STEP 3 **CONTROL BOX INSTALLATION:**

NOTE: Install the control box in this place only if the threads on the control panel are made of metal. Remove the two existing screws from the place where the control box will be installed. (Can be installed on the side of the control panel according to the model of the tractor).

# Item	Description	Action
1	Support plate	Install as shown.
2	Machine screw #10 x 32 x 1/2" (qty 2)	Insert as shown.
3	Box support	Install as shown.
4	Hex bolt 1/4" x 1/2" (qty 2)	Insert in the holes as shown.
5	Flange nuts (qty 2)	Tighten the bolts in place.
6	Control box	Install on the box support.

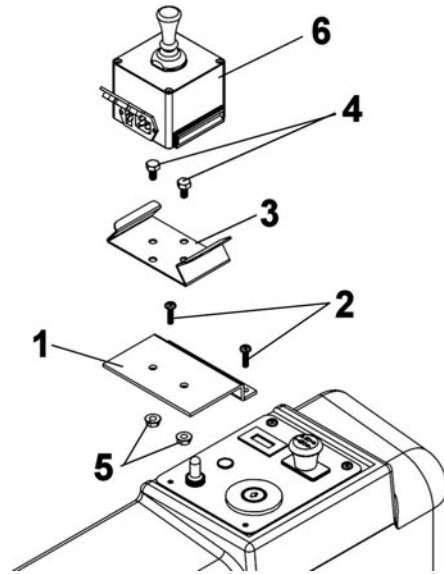

Install the control box

Thread the wires on the frame to the front where they will not be seen and where they won't touch any hot or moving parts.

Attach to the vehicle's frame using the tie wraps.

NOTE: It is recommended to place the wire connectors as close as possible to the subframe. Secure the wires in an adequate place in order to separate the accessory from the vehicle when storing.

Connect the wires to the electric motors. The longest wires are connected to the deflector motor.

Connect the red wire to the positive battery post and the black wire to the negative battery post.

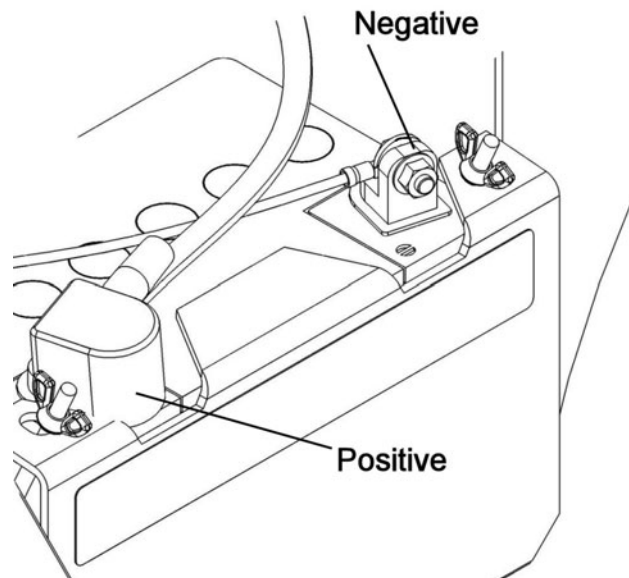

ASSEMBLY

Turn the chute to its maximum towards the right.

Secure the wire with another nylon tie wrap in the hole (item 1) at the base of the deflector as shown.

Secure the wire for the rotation motor (item 2) with a tie wrap.

Be sure to leave enough wire length to be able to turn the chute freely.

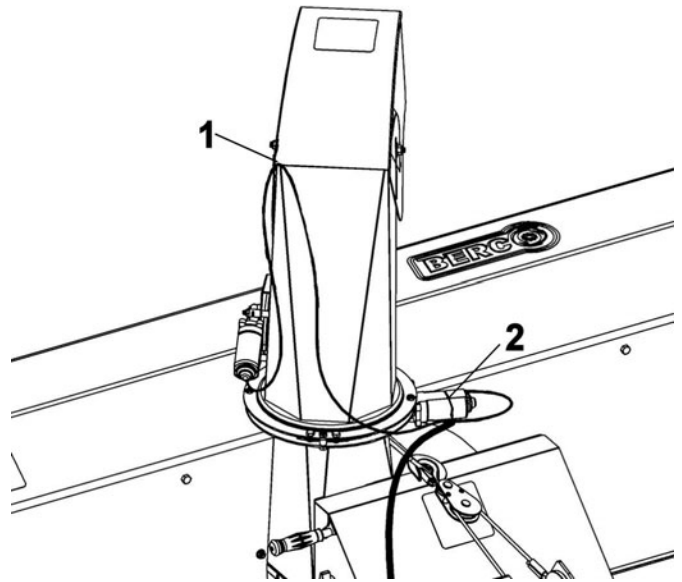

Important:

Take the time to familiarize yourself with the joystick (item A) on the control box.

Joystick identification:

- 1. Deflector: up and down
- 2. Chute: left to right

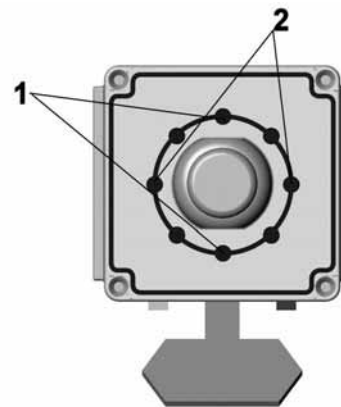
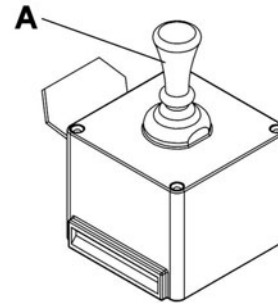

Identify the controls

ASSEMBLY

STEP 4

VERIFY SKID SHOE ADJUSTMENT:

LEVEL PAVED SURFACE: Adjust skid shoes to allow 3/16" to 1/4" clearance (A) between cutting edge and surface.

UNEVEN OR GRAVEL SURFACE: Adjust skid shoes to allow 1/2" to 5/8" clearance (A) between cutting edge and surface.

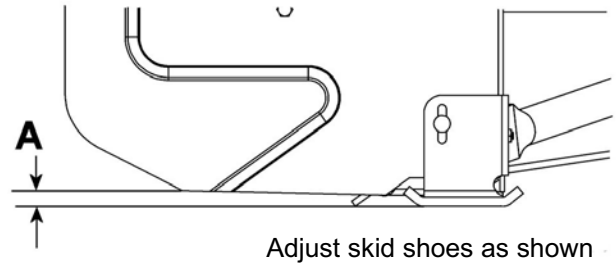

NOTE: Remove the belt guard before installing the spring.

INSTALLATION OF THE SPRING

NOTE: Lift the snowblower as high as it will go to install the spring.

# Item	Description	Action
1	Spring	Insert on end in the hole on the subframe.
2	Shackle	Insert in the other end of the spring (item 1) and then secure in the hole of the snowblower.

Reinstall the belt guard.

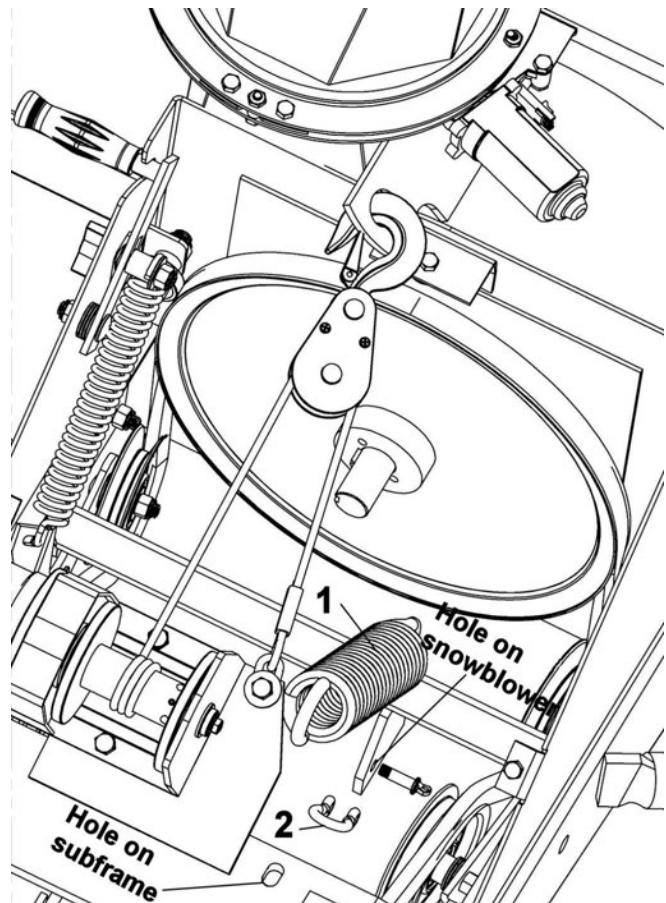

Install spring

OPERATION



WARNING



Read the vehicle's owner's manual carefully. Be thoroughly familiar with the controls & proper use of the attachment. Know how to stop the unit & disengage the controls quickly.



WARNING



TO PREVENT INJURIES AND FOR MORE TRACTION WHEN USING SNOWBLOWER:

- Do not drive faster than 3 km/hr (2 m/hr) with snowblower on the ground.
- Do not drive faster than 10 km/hr (6 m/hr) with the snowblower in raised position.
- Do not operate on a slope greater than 10°.
- Vehicle manufacturer approved tire chains are required.
- Counterweight kit sold separately.
- Familiarize yourself with driving the vehicle with the snowblower in the raised position.



WARNING



- Do not attempt to clear plugged chute, auger or fan of snow while the snowblower's engine is running.
- Disengage snowblower.
- Lower snowblower onto ground.
- Set the parking brake.
- Stop engine, remove the ignition key, disconnect the wire from spark plug(s) and keep away from spark plug(s) to prevent accidental starting.
- Make sure all moving parts have stopped.
- Do not use hand to unplug chute.
- Use a 36" (1m) minimum length stick or board.

OPERATING THE SNOWBLOWER

- Make sure the snowblower is clear of snow before engaging the clutch.
- Make sure that the auger and impeller operate freely.
- Start the snowblower engine.
- Before engaging the snowblower drive, always have the engine running at max R.P.M.
- Operate the snowblower at maximum engine R.P.M.

IMPORTANT: USE FULL ENGINE R.P.M. WHEN REMOVING WET, STICKY SNOW. LOW R.P.M. POWER WILL TEND TO PLUG THE CHUTE.

ELECTRICAL CONTROLS

See installation of the control box in order to identify the controls.

RAISING AND LOWERING THE SNOWBLOWER:

Press on the switch of the winch control to lift or lower the accessory to the ground.

There is a stopper that limits the lifting.

When lowering the accessory, release the switch of the winch control as soon as the accessory touches the ground.

REMOVING SNOW

When removing snow, do not use the snowblower as a dozer blade to push snow. Allow snowblower to ingest snow at its own speed. If the speed of your vehicle is too fast, the snowblower may become overloaded and plug.

CLEARING A CLOGGED DISCHARGE CHUTE:

Hand contact with the rotating impeller inside the discharge chute is the most common cause of injury associated with snowblowers. Never use your hand to clean out the discharge chute.

To clear the chute:

- Lower snowblower to the ground and set parking brake.
- SHUT THE ENGINE OFF & REMOVE KEY!
- Wait 10 seconds to be sure the **all moving parts** such as the impeller blades have stopped moving.
- Disconnect wire from the spark plug(s) and keep wire away to prevent accidental starting.
- Always use a clean-out tool of at least 36" in length, **NEVER YOUR HANDS.**

MAINTENANCE

Refer to parts breakdown section for parts identification.



WARNING



TO PREVENT INJURIES:

Stop the motor.
Apply parking brake.
Remove the ignition key.
Disconnect the wire from the spark plug(s) and keep away from spark plug(s) to prevent accidental starting.



CAUTION



TO PREVENT INJURIES:

-Check mounting bolts at frequent intervals for proper tightness in order to prevent costly repairs.
-Make sure your snowblower is in safe working condition.
-Provide adequate blocking before working under snowblower when in raised position.

ADJUSTMENTS

SKID SHOE ADJUSTMENT:

Level Paved Surface: Adjust skid shoes to obtain 3/16" to 1/4" clearance between cutting edge and surface.

Uneven or Gravel Surface: Adjust skid shoes to obtain 1/2" to 5/8" clearance between cutting edge and surface.

LUBRICATION

Apply oil at all pivot points.

Chute Rotation System:

Oil chute base, rotation worm when necessary.

Gear box:

Check the oil annually. If necessary, add AGMA 5 EP or SAE 90 oil.

The gear box should have a total of 155 ml of oil or filled to the rim of the bolt hole when installed on the snowblower.

CUTTING EDGE MAINTENANCE

Verify from time to time the wear on the cutting edge to make sure you do not wear out the base of the snowblower's frame. This cutting edge is reversible.

CLEARING A CLOGGED DISCHARGE CHUTE:



WARNING



TO PREVENT INJURIES:

-Do not attempt to clear plugged chute, auger or fan of snow while vehicle engine is running.
-Disengage attachment.
-Lower attachment onto ground.
-Set the parking brake.
-Stop engine, remove the ignition key, disconnect the wire from spark plug(s) and keep away from spark plug(s) to prevent accidental starting.
-Make sure all moving parts have stopped.
-Do not use hand to unplug chute.
-Use a 36" (1m) minimum length stick or board.

AUGERS AND FAN SHEAR BOLT REPLACEMENT

Shear bolts are to be considered a preventive measure and not an assured protection. Operator vigilance is required. Thoroughly inspect the areas where the snowblower is to be used and remove all foreign objects.

To avoid damage to the snowblower:

Use only the original shear bolts (grooved bolts).

#104000 in bags of 10 for the augers.

The use of any other shear bolt will not insure any protection and may void the warranty.

Use a 1/4" x 1 1/2" hex bolt grade 5 and nylon insert lock nut for the fan.

NOTE: The use of a higher grade of steel hex bolt may cause damage to the snowblower and may void the warranty.

Hex bolt 1/4" x 1 1/2" grade 5

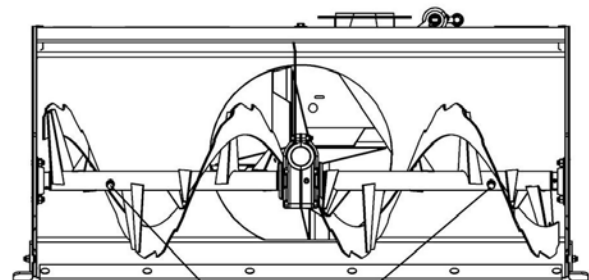
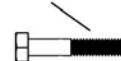

104000

MAINTENANCE

BELT INSTALLATION, ADJUSTMENT, AND REPLACEMENT:



WARNING



The belt tension arm is spring loaded & needs to be held firmly while displacing to prevent injury.

IMPORTANT:

When aligning or replacing the snowblower pulley (item 4), you must clean the parts and use "Lock-tite" 2760 on the key and the set screws. Tighten firmly.

SNOWBLOWER BELT:

- Lower the snowblower to the ground.
- Remove the belt guard.
- Remove tension on the belt by lowering the tension arm (item 1)
- Loosen the knob (item 2) on the bracket that holds the bearing (item 3).
- Install the belt as shown.
- Adjust the bracket by pushing on the bearing (item 3) to apply a slight pressure on the back of the belt (just enough to hold the belt in place). It is normal that the bearing is off centre (towards the vehicle) on the pulley. Just make sure that it does not come into contact with the wall of the pulley.

- Tighten firmly with the knob.
- Apply tension on the belt by pulling up the tension arm (item 1).
- Engage the snowblower for a few seconds. Stop the engine. Inspect the belt to make sure it does not interfere with any parts; that it is well inserted in the pulleys and that it has not flipped on it's side while still on the pulleys.
- Reinstall the belt guard.
- Use genuine belts only, they are specifically fabricated for this application.

NOTE: There must be a good tension on the belt at all times. If spring is damaged or stretched, you must replace it.

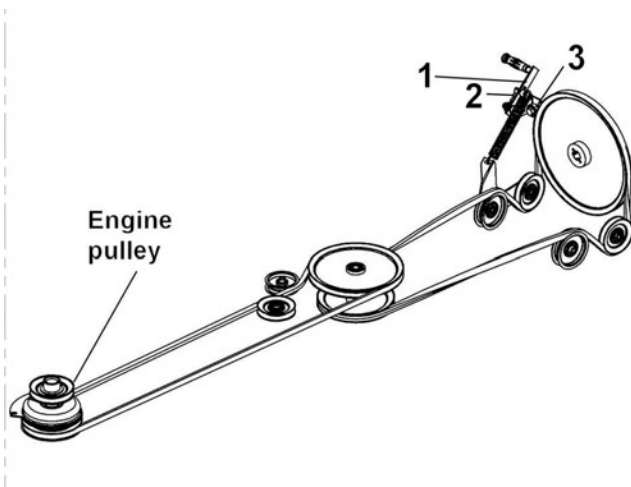

Position of the belts

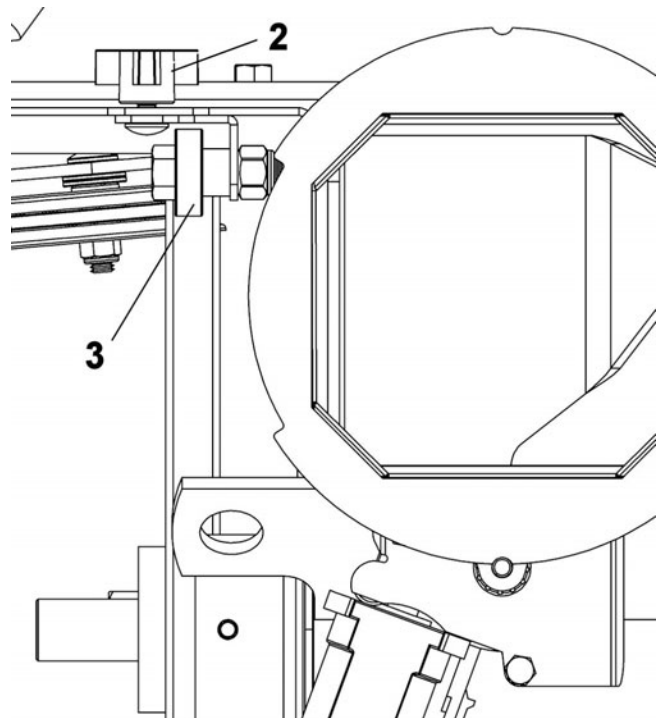

Top view
Position of the bearing

DISMOUNTING & STORAGE

SNOWBLOWER DISMOUNTING



CAUTION



The belt tension is spring loaded & needs to be held firmly while displacing to prevent injury.

- a) Remove the belt guard.
- b) Remove the spring.
- c) Unhook the pulley block from the snowblower.
- d) Release the tension on the belt by displacing the tension arm backwards. Remove the belt from the drive mechanism pulley under the tractor.
- e) Disconnect the electric connectors.
- f) Remove the snowblower by activating the latch of the female hitch and by backing up the vehicle.
- g) Reinstall the belt guard.

STORAGE

- a) Clean snowblower thoroughly and repaint all parts from which paint has worn.
- b) List the replacement parts that will be needed to be replaced before the next season.
- c) Follow the instructions in the Lubrication section.
- d) Store the snowblower, subframe and drive mechanism in a dry place.



WARNING



**Never use the snowblower without the belt guard.
Never operate the vehicle with the counterweights in place without the snowblower.**

TROUBLESHOOTING

* Please refer to parts breakdown section for parts identification.

PROBLEM	POSSIBLE CAUSES	CORRECTIVE ACTION
One section or both sections of the auger stops turning.	Shear bolts are probably broken.	Replace shear bolts.
Fan stops turning.	Shear bolt is probably broken.	Replace shear bolts.
Snowblower stops turning.	One of the two belts is probably damaged or broken.	Check both belts and replace damaged belt(s).
Belt snapping, shredding or burning	Lack of tension on belt.	Adjust the tension of the spring or replace springs if stretched.
	Snowblower engaged when plugged.	Make sure the auger & the fan are not frozen or plugged before engaging.
	Not original belts.	Always use original belts.
	Worn belt. Belt may be worn causing a slack.	Inspect the belt. Replace if required.
	Not original shear bolts.	Use original shear bolts
	Imperfections in pulleys.	Verify if the pulleys are damaged. Verify that pulleys are smooth, without rust spots. Sand down the pulleys or replace them.
	Interference.	Make sure that belt does not come into contact with any other part, bolts, guides etc... when engaged.
	Belt has flipped on its side.	When installing new belt, have snowblower run between 20 to 40 seconds. Turn everything off and verify that belt has not turned on its side. If so, remove belt and re-install in opposite fashion to rectify the bad twist the belt has taken.
Chute plugs easily.	Tractor engine turning too slowly.	Run engine at full throttle during snowblowing operation.
	Advancing too quickly with tractor.	Allow snowblower to ingest snow at its own speed.
Chute rotation is difficult.	Dirt or ice may be underneath chute.	Dismount chute. Clean the base of chute and the rotation ring. Lubricate & re-install.
Snowblower digs into ground.	Ground is not frozen or too soft.	Adjust skid shoes lower so they may better support the snowblower. If problem persists, change skid shoes for heavy duty skid shoes (option #700243) which cover more surface and prevents snowblower from digging.

TROUBLESHOOTING

* Please refer to parts breakdown section for parts identification.

PROBLEM	POSSIBLE CAUSES	CORRECTIVE ACTION
Snowblower does not raise evenly.	Tire pressure uneven from one side to another.	Verify and adjust tire pressure: Front tires: 14 to 15 psi Rear tires: 7 to 8 psi
Snowblower vibrates or is abnormally noisy.	Damaged pulley.	Replace pulley.
	Damaged bearing.	Replace bearing.
	Damaged fan.	Dismount & repair or replace fan.
	Damaged auger.	Replace auger.
Winch will not operate or runs in one direction only.	Vehicle's ignition switch is at OFF position.	Turn vehicle's ignition switch at ON position.
	Broken wires or bad connection.	Check for poor connections.
	Switch inoperative.	Replace switch.
	Breaker is damaged.	Replace breaker.
	Limit switch is damaged.	Replace limit switch.
	Winch is damaged.	Replace or repair winch.
Winch runs but with insufficient power or line speed.	Weak battery.	Recharge or replace battery. Check charging system
	Poor battery connection.	Check battery terminals for corrosion. Clean when required.
	Winch is damaged.	Replace or repair winch.
	Nylon bushing melted.	Replace bushing with brass one, 105227.
Winch runs but drum doesn't turn.	Clutch not engaged.	Engage clutch.

TROUBLESHOOTING

* Please refer to parts breakdown section for parts identification.

PROBLEM	POSSIBLE CAUSES	CORRECTIVE ACTION
Winch runs backwards.	Winch wires reversed.	Recheck wiring.
	Switch wires reversed.	Recheck wiring.
	Switch installed incorrectly.	Check switch installation.
	Battery wires reversed.	Recheck wiring.
	Winch cable is looped backwards.	Loop winch cable by underneath.
	POSSIBLE CAUSES	HOW TO KNOW?
	0) Poor connections	Recheck wiring with the owner's manual
	1) HI/LOW voltage tester is broken	Connect it on battery posts (+ and -) of a functional battery. If there is no light, the tester is damaged.
	2) Switch inoperative	Test both connectors with HI/LOW voltage tester. If light comes ON in both positions (IN & OUT), the switch is OK.
	3) Breaker is damaged	When it is working, there is a "CLICK" sound when activated. Check connections with HI/LOW voltage tester.
	4) Winch is damaged	The ultimate test is to connect the winch directly to the battery. Test both directions. If the winch doesn't work, it is damaged.
	5) Limit switch is damaged	If the limit switch is functional: when it is pushed, the winch can't go up; just down.

TORQUE SPECIFICATION TABLE

GENERAL TORQUE SPECIFICATION TABLE USE THE FOLLOWING TORQUES WHEN SPECIAL TORQUES ARE NOT GIVEN

NOTE: These values apply to fasteners as received from supplier, dry or when lubricated with normal oil. They do not apply if special graphited or moly disulphide greases or other extreme pressure lubricants are used. This applies to both UNF and UNC threads.

* Thick nuts must be used with grade 8 bolts

SEE Grade No.		2				5				8 *			
BOLT HEAD IDENTIFICATION MARKS AS PER GRADE NOTE MANUFACTURING MARKS WILL VARY		TORQUE				TORQUE				TORQUE			
BOLT SIZE		FOOT POUNDS		NEWTON-METERS		FOOT POUNDS		NEWTON-METERS		FOOT POUNDS		NEWTON-METERS	
Inches	Millimetre	Min.	Max.	Min.	Max.	Min.	Max.	Min.	Max.	Min.	Max.	Min.	Max.
1/4"	6.35	5	6	6.8	8.13	9	11	12.2	14.9	12	15	16.3	30.3
5/16"	7.94	10	12	13.6	16.3	17	20.5	23.1	27.8	24	29	32.5	39.3
3/8"	9.53	20	23	27.1	31.2	35	42	47.5	57	45	54	61	73.2
7/16"	11.11	30	35	40.7	47.4	54	64	73.2	86.8	70	84	94.9	113.9
1/2"	12.7	45	52	61	70.5	80	96	108.5	130.2	110	132	149.2	179
9/16"	14.29	65	75	88.1	101.6	110	132	149.2	179	160	192	217	260.4
5/8"	15.88	95	105	128.7	142.3	150	180	203.4	244.1	220	264	298.3	358
3/4"	19.05	150	185	203.3	250.7	270	324	366.1	439.3	380	456	515.3	618.3
7/8"	22.23	160	200	216.8	271	400	480	542.4	650.9	600	720	813.6	976.3
1"	25.4	250	300	338.8	406.5	580	696	786.5	943.8	900	1080	1220.4	1464.5

METRIC BOLT TORQUE SPECIFICATIONS							
		COARSE THREAD			FINE THREAD		
Size Screw	Grade No.	Pitch (mm)	Foot Pounds	Newton-Meters	Pitch (mm)	Foot Pounds	Newton-Meters
M6	4T	1.00	3.6 - 5.8	4.9 - 7.9	-	-	-
	7T		5.8 - 9.4	7.9 - 12.7		-	-
	8T		7.2 - 10	9.8 - 13.6		-	-
M8	4T	1.25	7.2 - 14	9.8 - 19	1.00	12 - 17	16.3 - 23
	7T		17 - 22	23 - 29.8		19 - 27	25.7 - 36.6
	8T		20 - 26	27.1 - 35.2		22 - 31	29.8 - 42
M10	4T	1.50	20 - 25	27.1 - 33.9	1.25	20 - 29	27.1 - 39.3
	7T		34 - 40	46.1 - 54.2		35 - 47	47.4 - 63.7
	8T		38 - 46	51.5 - 62.3		40 - 52	54.2 - 70.5
M12	4T	1.75	28 - 34	37.9 - 46.1	1.25	31 - 41	42 - 55.6
	7T		51 - 59	69.1 - 79.9		56 - 68	75.9 - 92.1
	8T		57 - 66	77.2 - 89.4		62 - 75	84 - 101.6
M14	4T	2.00	49 - 56	66.4 - 75.9	1.50	52 - 64	70.5 - 86.7
	7T		81 - 93	109.8 - 126		90 - 106	122 - 143.6
	8T		96 - 109	130.1 - 147.7		107 - 124	145 - 168
M16	4T	2.00	67 - 77	90.8 - 104.3	1.50	69 - 83	93.5 - 112.5
	7T		116 - 130	157.2 - 176.2		120 - 138	162.6 - 187
	8T		129 - 145	174.8 - 196.5		140 - 158	189.7 - 214.1
M18	4T	2.00	88 - 100	119.2 - 136	1.50	100 - 117	136 - 158.5
	7T		150 - 168	203.3 - 227.6		177 - 199	239.8 - 269.6
	8T		175 - 194	237.1 - 262.9		202 - 231	273.7 - 313
M20	4T	2.50	108 - 130	146.3 - 176.2	1.50	132 - 150	178.9 - 203.3
	7T		186 - 205	252 - 277.8		206 - 242	279.1 - 327.9
	8T		213 - 249	288.6 - 337.4		246 - 289	333.3 - 391.6

PARTS BREAKDOWN 66" SNOWBLOWER

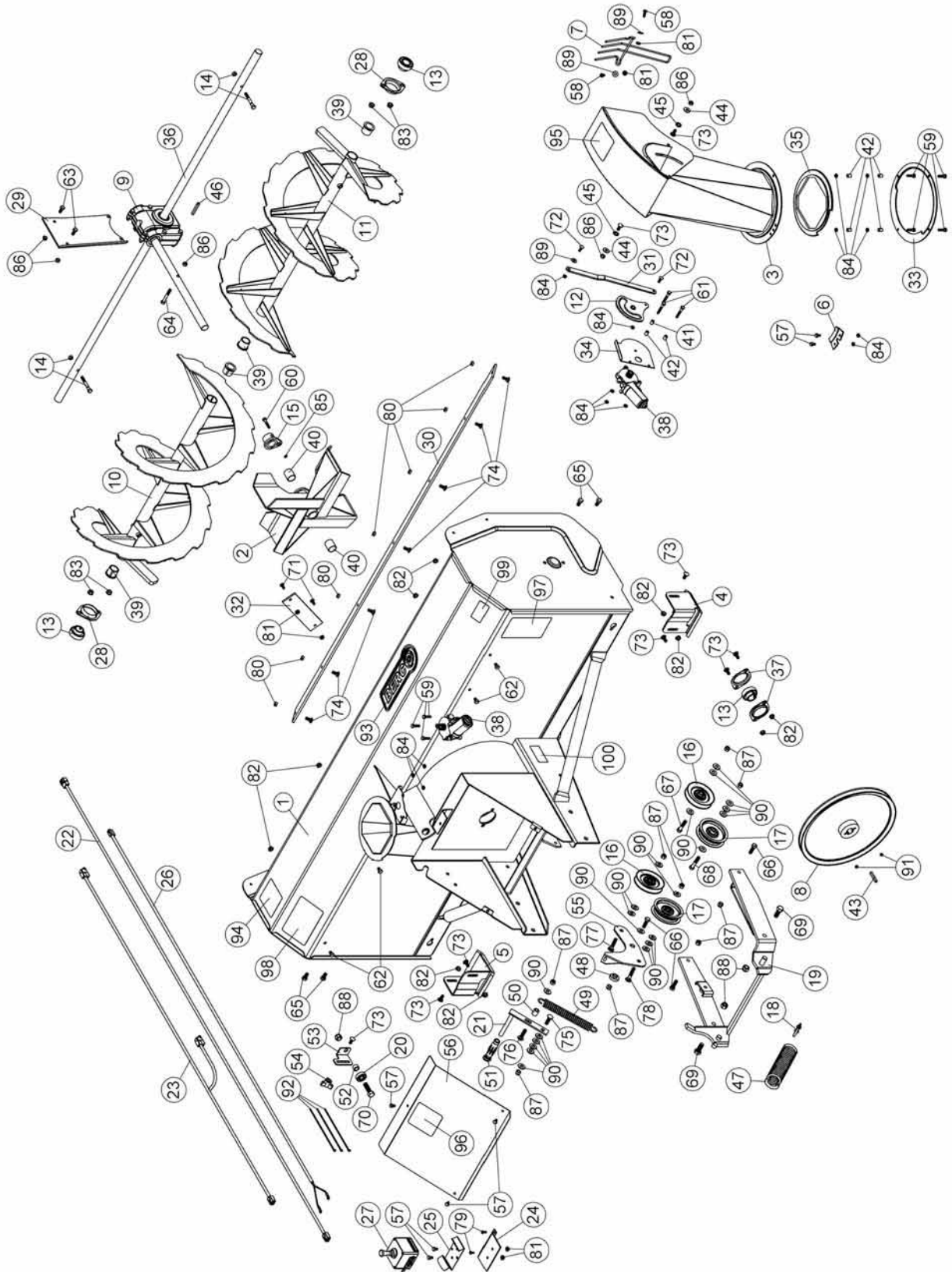

PARTS LIST 66" SNOWBLOWER

Ref. Réf.	English description	Description française	Qty. Qté.	Part # Pièce #
1	Frame 66"	Châssis 66"	1	105583
2	Fan	Éventail	1	105475
3	Chute	Goulotte	1	105476
4	Right skid shoe	Patin droit	1	105486
5	Left skid shoe	Patin gauche	1	105487
6	Retaining plate	Plaque de retenue	1	105488
7	Hand guard	Fourche protectrice	1	105494
8	V pulley with set screw	Poulie en V avec vis pression	1	105423
9	Gear box left rotation	Boîte d'engrenage rotation gauche	1	105424
10	Auger 66" left	Vis 66" gauche	1	105427
11	Auge 66" right	Vis 66" droite	1	105428
12	Lever	Levier	1	103365
13	Bearing with set screw	Roulement à billes avec vis à pression	3	102755
14	Shear bolt / N.I.L.N. (auger) pkg-10	Boulon de séc. / É.G.N. (vis) pkg-10	2	104000
15	Shear plate	Plaque de cisaillement	1	103933
16	V pulley	Poulie en V	2	102766
17	Flat pulley	Poulie plate	2	102765
18	Shackle Ptd Z	Clevis Pqé Z	1	102343
19	Male hitch	Attache mâle	1	105584
20	Bearing	Roulement à billes	1	104624
21	Tension arm	Bras de tension	1	103026
22	Wire control box extension	Extension du fil de la boîte de contrôle	1	105405
23	Wire control box	Fil de la boîte de contrôle	1	105326
24	Support plate	Plaque de support	1	105585
25	Box support	Support de la boîte	1	105395
26	Wire assembly	Fil assemblé	1	105390
27	Control box	Boîtier de contrôle	1	105325
28	Flangette	Flangette	2	102680
29	Gear box support	Support de boîte d'engrenage	1	105477
30	Cutting edge 66"	Racloir 66"	1	105478
31	Arm	Bras	1	105480
32	Reinforcement	Renfort	1	105484
33	Rotation ring	Anneau de rotation	1	105485

O/L = Obtain Locally

PARTS LIST 66" SNOWBLOWER

Ref. Réf.	English description	Description française	Qty. Qté.	Part # Pièce #
34	Bracket	Support	1	105492
35	Rotation ring	Anneau de rotation	1	105429
36	Shaft 66"	Arbre 66"	1	105436
37	Flangette	Flangette	2	102213
38	Electric motor	Moteur électrique	2	103378
39	Rotation bushing	Coussinet de rotation	4	103946
40	Oil lite bushing	Coussinet imprégné d'huile	2	102784
41	Oil lite bushing	Coussinet imprégné d'huile	1	103362
42	Spacer	Espaceur	6	103361
43	Key 1/4" x 1/4" x 1 3/4"	Clé 1/4" x 1/4" x 1 3/4"	1	102327
44	Nylon flat washer 11/32"	Rondelle plate de nylon 11/32"	2	102009
45	Nylon flat washer 7/16"	Rondelle plate de nylon 7/16"	2	102011
46	Key 1/4" x 1/4" x 2"	Clé 1/4" x 1/4" x 2"	1	102922
47	Spring	Ressort	1	105356
48	Flange washer	Rondelle à bride	1	102081
49	Spring	Ressort	1	102861
50	Sleeve	Douille	1	103028
51	Handgrip	Poignée	1	102062
52	Bushing	Coussinet	1	102225
53	Bracket	Fixation	1	104734
54	Knob	Bouton	1	103027
55	Tension lever	Levier de tension	1	105586
56	Belt guard	Garde-courroie	1	105587
57	Hex. bolt 1/4" n.c. x 1/2"	Boulon hex. 1/4" n.c. x 1/2"	7	O/L
58	Hex. bolt 1/4" n.c. x 3/4"	Boulon hex. 1/4" n.c. x 3/4"	2	O/L
59	Hex. bolt 1/4" n.c. x 1"	Boulon hex. 1/4" n.c. x 1"	7	O/L
60	Hex. bolt 1/4" n.c. x 1 1/2"	Boulon hex. 1/4" n.c. x 1 1/2"	1	O/L
61	Hex. bolt 1/4" n.c. x 1 3/4"	Boulon hex. 1/4" n.c. x 1 3/4"	3	O/L
62	Hex. bolt 5/16" n.c. x 1/2"	Boulon hex. 5/16" n.c. x 1/2"	4	O/L
63	Hex. bolt 5/16" n.c. x 3/4"	Boulon hex. 5/16" n.c. x 3/4"	2	O/L
64	Hex. bolt 5/16" n.c. x 2 1/4" GR8	Boulon hex. 5/16" n.c. x 2 1/4" GR8	1	O/L
65	Hex. bolt 3/8" n.c. x 3/4"	Boulon hex. 3/8" n.c. x 3/4"	4	O/L
66	Hex. bolt 3/8" n.c. x 1 1/4"	Boulon hex. 3/8" n.c. x 1 1/4"	3	O/L

O/L = Obtain Locally

PARTS LIST 66" SNOWBLOWER

Ref. Réf.	English description	Description française	Qty. Qté.	Part # Pièce #
67	Hex. bolt 3/8" n.c. x 1 3/4"	Boulon hex. 3/8" n.c. x 1 3/4"	1	O/L
68	Hex. bolt 3/8" n.c. x 2"	Boulon hex. 3/8" n.c. x 2"	1	O/L
69	Hex. bolt 1/2" n.c. x 1 1/4"	Boulon hex. 1/2" n.c. x 1 1/4"	2	O/L
70	Hex. bolt 1/2" n.c. x 1 3/4"	Boulon hex. 1/2" n.c. x 1 3/4"	1	O/L
71	Carriage bolt 1/4" n.c. x 5/8"	Boulon à carrosserie 1/4" n.c. x 5/8"	2	O/L
72	Carriage bolt 1/4" n.c. x 3/4"	Boulon à carrosserie 1/4" n.c. x 3/4"	2	O/L
73	Carriage bolt 5/16" n.c. x 3/4"	Boulon à carrosserie 5/16" n.c. x 3/4"	9	O/L
74	Carriage bolt 5/16" n.c. x 3/4"(Black)	Boulon à carrosserie 5/16" n.c. x 3/4"(Noir)	7	O/L
75	Carriage bolt 3/8" n.c. x 1 1/4"	Boulon à carrosserie 3/8" n.c. x 1 1/4"	1	O/L
76	Carriage bolt 3/8" n.c. x 1-1/2"	Boulon à carrosserie 3/8" n.c. x 1 1/2"	1	O/L
77	Carriage bolt 3/8" n.c. x 1 3/4"	Boulon à carrosserie 3/8" n.c. x 1 3/4"	1	O/L
78	Carriage bolt 3/8" n.c. x 2"	Boulon à carrosserie 3/8" n.c. x 2"	1	O/L
79	Machine screw P.H. #10 x 32 x 1/2"	Vis mécanique P.H. #10 x 32 x 1/2"	2	O/L
80	Stover lock nut 5/16" n.c.	Écrou de blocage 5/16" n.c.	7	O/L
81	Flange nut 1/4" n.c.	Écrou à bride 1/4" n.c.	6	O/L
82	Flange nut 5/16" n.c.	Écrou à bride 5/16" n.c.	10	O/L
83	Flange nut 3/8" n.c.	Écrou à bride 3/8" n.c.	4	O/L
84	Nylon insert lock nut 1/4" n.c. (thin)	Écrou à garniture de nylon 1/4" n.c.(mince)	14	O/L
85	Nylon insert lock nut 1/4" n.c.	Écrou a garniture de nylon 1/4" n.c.	1	O/L
86	Nylon insert lock nut 5/16" n.c.	Écrou à garniture de nylon 5/16" n.c.	5	O/L
87	Nylon insert lock nut 3/8" n.c.	Écrou à garniture de nylon 3/8" n.c.	9	O/L
88	Nylon Insert lock Nut 1/2" n.c.	Écrou à garniture de nylon 1/2" n.c.	3	O/L
89	Flat washer 5/16" hole	Rondelle plate 5/16" trou	3	O/L
90	Flat washer 7/16" hole	Rondelle plate 7/16" trou	21	O/L
91	Hex. socket set screw 5/16" n.c. x 5/16"	Vis à pression hex. 5/16" n.c. x 5/16"	2	O/L
92	Tie wrap 8"	Attache de nylon 8"	3	O/L
93	Berco decal	Décalque Berco	1	103785
94	Decal danger auger	Decalque danger vis	1	105126
95	Danger decal chute	Décalque danger goulotte	1	105127
96	Decal danger belts	Decalque danger courroies	1	105128
97	Decal read instructions	Decalque lire instructions	1	105130
98	Decal warning safety	Decalque avertissement sécurité	1	105131
99	Specifications decal	Décalque spécifications	1	REF
100	Serial number	Numéro de série	1	REF

OPTIONS & ATTACHMENTS



SNOW DRIFT CUTTER
#700535
Facilitates and increases snow
intake.
Pkg. of 2

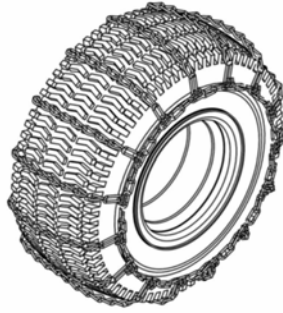

TIRE CHAINS
Two link spacing. Required for
traction and safety.
Pkg. of 2

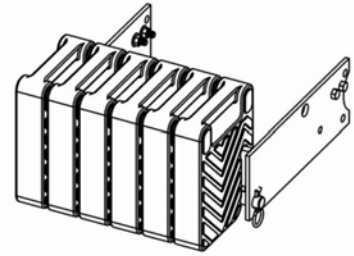

COUNTERWEIGHT
Model # as per tractor
Required for safety and traction.
Counter-balances weight of
attachment.



*WHEN PERFORMANCE
& DEPENDABILITY
ARE NON NEGOTIABLE!*

Bercomac Limitée
92, Fortin North, Adstock, Quebec, Canada, G0N 1S0

WWW.BERCOMAC.COM

PRINTED IN CANADA